

IEC Terminal Blocks

- Mini Blocks Page 12-8
 - Standard and Feed-Through Blocks Page 12-10
 - Multi-Circuit Blocks Page 12-13
 - Specialty Feed-Through Blocks Page 12-14
 - Sensor Blocks Page 12-15
 - Grounding Blocks Page 12-17
 - Isolation Blocks Page 12-19
 - Plug-In Style Blocks Page 12-21
 - Two Level Plug-In Style Blocks Page 12-22
 - Two Level Plug-In Style Blocks with Ground Page 12-23
 - Fuse Blocks Page 12-24
 - Installation Blocks Page 12-27
 - Component Blocks Page 12-29
 - Resistor Blocks Page 12-31
 - Surge Suppressor Blocks Page 12-32
 - Thermocouple Blocks Page 12-33
-

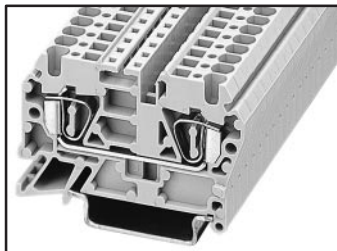

QuickClamp™ Terminal Blocks

- Standard Blocks Page 12-36
 - Plug-In Style Blocks Page 12-41
 - Multi-Circuit Blocks Page 12-42
 - Isolation Blocks Page 12-43
 - Component Blocks Page 12-44
 - Sensor Blocks Page 12-46
 - Standard Grounding Blocks Page 12-49
-

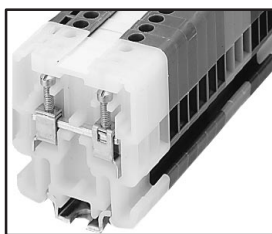

Finger-Safe Terminal Blocks

- High Density Page 12-53
 - Isolation Switch Blocks Page 12-55
 - Fuse Blocks Page 12-56
 - Surge Suppressor Blocks Page 12-58
 - Resistor Blocks Page 12-59
 - Voltage Indicating Blocks Page 12-60
 - Component Blocks Page 12-61
-

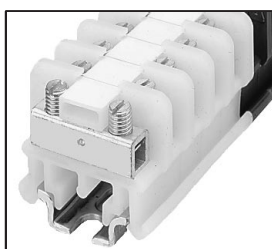

NEMA/EEMAC Terminal Blocks

- Open Construction Blocks Page 12-64
 - Isolation Switch Blocks Page 12-69
 - Fuse Blocks Page 12-70
-



Panel Mount Blocks

- Panel Mount Blocks

Page 12-74



Power Blocks

- Power Blocks

Page 12-78



Circuit Protection

- Fuse Holders
- Circuit Breakers

Page 12-90

Page 12-92

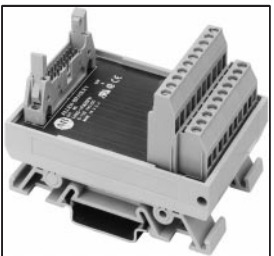

Programmable Controller Wiring Systems

- Interface Modules
- Cable Specifications
- Pre-wired Cable and IFM Selection Tables
- Marking Systems

Page 12-106

Page 12-122

Page 12-124

Page 12-127



Accessories and Technical Specifications

- DIN Mounting Rails
- Allen-Bradley Mounting Rails
- End Anchors
- End Barriers
- Partition Plates/Seperation Plates
- Jumpers/Fanning Strips/Fuse Holders
- General Accessories
- QuickClamp™ Accessories
- Marking Systems
- Technical Specifications
- UL/CSA File and Guide Numbers

Page 12-143

Page 12-144

Page 12-146

Page 12-147

Page 12-149

Page 12-150

Page 12-151

Page 12-152

Page 12-154

Page 12-165

Page 12-171

Catalog Number	Page	Catalog Number	Page	Catalog Number	Page
199-DR1	12-143	1492-CABLE-D	12-122	1492-CJD6-10	12-8, 12-13, 12-29
1492-100X	12-83	1492-CABLE-E	12-122	1492-CJD6-2	12-8, 12-13, 12-29
1492-100XF	12-79	1492-CABLE-F	12-122	1492-CJD6-3	12-8, 12-13, 12-29
1492-100Y	12-83	1492-CABLE-FF	12-122	1492-CJL5	12-150
1492-100YF	12-79	1492-CABLE-G	12-122	1492-CJL6	12-150
1492-15A	12-146	1492-CABLE-H	12-122	1492-CJL7	12-150
1492-15E	12-146	1492-CABLE-J	12-122	1492-CJL8	12-150
1492-15T	12-75	1492-CABLE-K	12-122	1492-CJM5-10	12-8
1492-25A	12-146	1492-CABLE-L	12-122	1492-CJN6-10	12-27
1492-25E	12-146	1492-CABLE-M	12-122	1492-CJN6-2	12-27
1492-25T	12-75	1492-CABLE-N	12-122	1492-CJN6-3	12-27
1492-50X	12-82	1492-CABLE-N3	12-123	1492-CJR5-10	12-152
1492-50XF	12-79	1492-CABLE-P	12-123	1492-CJR5-10-B	12-152
1492-50Y	12-82	1492-CABLE-Q	12-123	1492-CJR5-10-R	12-152
1492-50YF	12-78	1492-CABLE-R	12-122	1492-CJR6-10	12-152
1492-ACABLE-A	12-122	1492-CABLE-RTBB	12-123	1492-CJR8-10	12-152
1492-ACABLE-B	12-122	1492-CABLE-RTBO	12-123	1492-CJRL5	12-152
1492-ACABLE-C	12-122	1492-CABLE-RTBR	12-123	1492-CJRL6	12-152
1492-ACABLE-D	12-122	1492-CABLE-WA	12-123	1492-CJSL6-2	12-150
1492-ACABLE-E	12-122	1492-CABLE-WD	12-123	1492-CJT5-10	12-15, 12-16
1492-ACABLE-F	12-122	1492-CABLE-WH	12-123	1492-CP4	12-30
1492-ACABLE-G	12-122	1492-CABLE-WHF	12-123	1492-DISPEN	12-155
1492-ACABLE-H	12-122	1492-CABLE-WN	12-123	1492-DP4	12-21, 12-23
1492-ACABLE-J	12-122	1492-CAM1	12-66	1492-DR3	12-143
1492-ACABLE-L	12-122	1492-CAM1L	12-66	1492-DR5	12-143
1492-ACBA1	12-95	1492-CAM2	12-67	1492-DR6	12-143
1492-ACBA2	12-95	1492-CB1(CIRCUIT BREAKER)	12-94	1492-DR7	12-143
1492-ACBA3	12-95	1492-CB2(CIRCUIT BREAKER)	12-94	1492-EA15	12-146
1492-ACBA4	12-95	1492-CB3(CIRCUIT BREAKER)	12-94	1492-EA35	12-146
1492-ACBA5	12-95	1492-CBB9-10	12-150	1492-EAH35	12-146
1492-ACBCC1	12-95	1492-CD2	12-67	1492-EB10	12-147
1492-ACBCL1	12-95	1492-CD2130	12-67	1492-EB10-Y	12-147
1492-ACBCL2	12-95	1492-CD3	12-68	1492-EB16	12-147
1492-ACBCL3	12-95	1492-CD3130	12-68	1492-EB3	12-147
1492-ACBH1	12-95	1492-CD8	12-68	1492-EB3-Y	12-147
1492-ACBH2	12-95	1492-CD8130	12-68	1492-EB35	12-147
1492-ACBHS1	12-95	1492-CE2	12-67	1492-EB3TW	12-147
1492-ACBS1	12-95	1492-CE6	12-72	1492-EBD3	12-147
1492-ACBS2	12-95	1492-CE9	12-69	1492-EBD4N	12-147
1492-AIFM16-F-3	12-121	1492-CJ11-10	12-11	1492-EBD4P	12-148
1492-AIFM16-F-5	12-121	1492-CJ11-4	12-11	1492-EBD6	12-148
1492-AIFM4-3	12-119	1492-CJ11-5	12-11	1492-EBKD3	12-147
1492-AIFM4C-F-5	12-120	1492-CJ14-2	12-12	1492-EBKD6	12-147
1492-AIFM4I-F-5	12-120	1492-CJ14-3	12-12	1492-EBM3	12-147
1492-AIFM6S-3	12-119	1492-CJ5-10	12-10, 12-14	1492-EBM4	12-147
1492-AIFM8-3	12-119	1492-CJ5-2	12-10, 12-14	1492-EBMD1	12-147
1492-AIFM8-F-5	12-120	1492-CJ5-3	12-10, 12-14	1492-EBR3	12-148
1492-ALHFB	12-154	1492-CJ6-10	12-10	1492-EBTF3	12-147
1492-ALWFB	12-154	1492-CJ6-2	12-10	1492-EBTS3	12-147
1492-BE	12-83	1492-CJ6-3	12-10	1492-EC85	12-76
1492-BF	12-84	1492-CJ7-10	12-10	1492-ED103	12-76
1492-BG	12-85	1492-CJ7-2	12-10	1492-ER35	12-153
1492-CA1	12-65	1492-CJ7-3	12-10	1492-EWP11-4	12-152
1492-CA1175	12-65	1492-CJ8-10	12-11	1492-EWP14-4	12-152
1492-CA1L	12-65	1492-CJ8-2	12-11	1492-EWP5-4	12-152
1492-CA1L175	12-65	1492-CJ8-3	12-11	1492-EWP6-4	12-152
1492-CA2	12-66	1492-CJCB5	12-152	1492-EWP7-4	12-152
1492-CA2175	12-66	1492-CJCR5	12-152	1492-EWP8-4	12-152
1492-CA3	12-68	1492-CJCW5	12-152	1492-F1	12-64
1492-CA3175	12-68	1492-CJCW6	12-152	1492-F1209	12-64
1492-CABLE-A	12-122	1492-CJD5-10	12-13	1492-F2	12-64
1492-CABLE-B	12-122	1492-CJD5-2	12-13	1492-F2209	12-64
1492-CABLE-C	12-122	1492-CJD5-3	12-13	1492-F3	12-64

Catalog Number Index

Catalog Number	Page	Catalog Number	Page	Catalog Number	Page
1492-F3175	12-64	1492-IFM20D120-2	12-110	1492-N4	12-154
1492-F8	12-65	1492-IFM20D120A-2	12-110	1492-N40	12-148
1492-F8175	12-65	1492-IFM20D120N	12-109	1492-N41	12-154
1492-FB1	12-91	1492-IFM20D24	12-107	1492-N42	12-150
1492-FB2	12-91	1492-IFM20D24-2	12-108	1492-N43	12-154
1492-FB3	12-91	1492-IFM20D24-3	12-108	1492-N43100	12-154
1492-FP4	12-21, 12-22, 12-23	1492-IFM20D24A-2	12-108	1492-N4350	12-154
1492-FP424	12-21, 12-22, 12-23	1492-IFM20D24N	12-107	1492-N44	12-144
1492-FP4250	12-21, 12-22, 12-23	1492-IFM20F	12-106	1492-N45	12-154
1492-GH002	12-98	1492-IFM20F-2	12-106	1492-N46	12-150
1492-GH005	12-98	1492-IFM20F-3	12-107	1492-N47	12-146
1492-GH008	12-98	1492-IFM20F-F120-2	12-111	1492-N49	12-150
1492-GH010	12-98	1492-IFM20F-F-2	12-111	1492-N5	12-154
1492-GH012	12-98	1492-IFM20F-F24-2	12-111	1492-N711	12-95
1492-GH015	12-98	1492-IFM20F-F24A-2	12-112	1492-N712	12-95
1492-GH020	12-98	1492-IFM20FN	12-106	1492-N713	12-95
1492-GH025	12-98	1492-IFM40D120-2	12-116	1492-N714	12-95
1492-GH030	12-98	1492-IFM40D120A-2	12-117	1492-N715	12-95
1492-GH040	12-98	1492-IFM40D24	12-114	1492-N8	12-154
1492-GH050	12-98	1492-IFM40D24-2	12-115	1492-N80	12-57, 12-72
1492-GH070	12-98	1492-IFM40D24-3	12-116	1492-N88	12-151
1492-GH100	12-98	1492-IFM40D24A-2	12-115	1492-N90	12-151
1492-GH150	12-98	1492-IFM40F	12-113	1492-N901	12-154
1492-GM35	12-152	1492-IFM40F-2	12-113	1492-NBB3-1M	12-150
1492-GS	12-102	1492-IFM40F-3	12-114	1492-NM16	12-148
1492-H1	12-53	1492-IFM40F-F-2	12-117	1492-NM16BL	12-148
1492-H1296	12-53	1492-IFM40F-F120-2	12-118	1492-NM16GL	12-148
1492-H2	12-53	1492-IFM40F-F24-2	12-118	1492-NM36	12-148
1492-H2148	12-53	1492-IFMFH1	12-150	1492-NM40	12-148
1492-H2C	12-61	1492-MP	12-159	1492-PD31123	12-81
1492-H2D	12-61	1492-MR9	12-152, 12-154	1492-PD3113	12-84
1492-H2K024	12-58	1492-MR15	12-152, 12-154	1492-PD3141	12-80
1492-H2K120	12-58	1492-N1	12-144	1492-PD3163	12-80
1492-H2K240	12-58	1492-N12	12-151	1492-PD3183	12-81
1492-H2RA***	12-59	1492-N13	12-150	1492-PD32127	12-81
1492-H2RB***	12-59	1492-N14	12-150	1492-PD3226	12-84
1492-H2RC001	12-59	1492-N15	12-150	1492-PD3263	12-80
1492-H2V24	12-60	1492-N16	12-148	1492-PD3287	12-82
1492-H2V250	12-60	1492-N17	12-148	1492-PD3C111	12-85
1492-H4	12-25, 12-56, 12-71	1492-N18	12-148	1492-PD3C112	12-86
1492-H5	12-25, 12-56, 12-71	1492-N2	12-146	1492-PD3C141	12-85
1492-H6	12-25, 12-56, 12-71	1492-N20	12-150	1492-PD3C163	12-86
1492-H7	12-20, 12-55, 12-69	1492-N21	12-150	1492-PD3C2127	12-87
1492-HC6	12-74	1492-N22	12-144	1492-PD3C263	12-86
1492-HJ812	12-74	1492-N23	12-146	1492-PD3C287	12-87
1492-HJ86	12-74	1492-N24	12-150	1492-PDM3111	12-78
1492-HM1	12-54	1492-N25	12-144	1492-PDM3141	12-78
1492-HM2	12-54	1492-N26	12-145	1492-PLTKIT	12-155
1492-HM2C	12-51, 12-61	1492-N27	12-145	1492-PP10	12-149
1492-HM2D	12-51, 12-61	1492-N28	12-145	1492-PP16	12-149
1492-HM2K024	12-52, 12-58	1492-N29	12-145	1492-PP3	12-149
1492-HM2K120	12-52, 12-58	1492-N3	12-150	1492-PP35	12-149
1492-HM2K240	12-52, 12-58	1492-N30	12-150	1492-PPD3	12-149
1492-HM2RA***	12-51, 12-59	1492-N32	12-145	1492-PPD4P	12-149
1492-HM2RB001	12-51, 12-59	1492-N35	12-150	1492-PPD6	12-149
1492-HM2RC001	12-51, 12-59	1492-N36	12-148	1492-PPM3	12-149
1492-HM2V24	12-52, 12-60	1492-N37	12-148	1492-PPMD1	12-149
1492-HM2V250	12-52, 12-60	1492-N38	12-150	1492-PPSL3	12-19
1492-HM3	12-54	1492-N39	12-150	1492-PPTS3	12-149
1492-IFM20D120	12-109				

Catalog Number	Page	Catalog Number	Page	Catalog Number	Page
1492-PS3-02	12-152	1492-TCS	12-153	1492-WTC3E	12-33
1492-PS3-05	12-152	1492-TP15	12-151	1492-WTC3J	12-33
1492-PS3-10	12-152	1492-TP23	12-151	1492-WTC3K	12-33
1492-PS4-05	12-152	1492-TP28	12-151	1492-WTC3T	12-33
1492-PS4-15	12-152	1492-UF3	12-57, 12-72	1492-WTF3	12-15
1492-PS6-05	12-152	1492-W10	12-11	1492-WTF3LN	12-15
1492-PS6-15	12-152	1492-W16	12-11	1492-WTF3LP	12-15
1492-R3	12-36	1492-W16S	12-11	1492-WTS3	12-16
1492-R3Q	12-36	1492-W3	12-10	1492-WTS3LN	12-16
1492-R3T	12-37	1492-W35	12-12	1492-WTS3LP	12-16
1492-R4	12-37	1492-W3TW	12-14		
1492-R4DJ	12-38	1492-W4	12-10		
1492-R4P	12-41	1492-W4P	12-21, 12-26, 12-30		
1492-R4Q	12-38	1492-W4PTP	12-21		
1492-R4T	12-39	1492-W6	12-10		
1492-R6	12-40	1492-W70	12-12		
1492-R6T	12-40	1492-WD3	12-13		
1492-RD3	12-42	1492-WD4	12-13		
1492-RD3DF	12-44	1492-WDG4N	12-27		
1492-RD3DR	12-44	1492-WNC16	12-150		
1492-RD3DRB	12-45	1492-WNC35	12-150		
1492-RD3SS	12-45	1492-WDG4ND	12-27		
1492-RG3	12-49	1492-WDG4NSS	12-28		
1492-RG4	12-49	1492-WD4C	12-29		
1492-RG6	12-50	1492-WD4DF	12-29		
1492-RKD3	12-43	1492-WD4DR	12-29		
1492-RTS2	12-46	1492-WD4N	12-27		
1492-RTSG2	12-46	1492-WD4P	12-22		
1492-RTSG2LN	12-47	1492-WD4RA	12-31		
1492-RTSG2LP	12-47	1492-WD4RC001	12-31		
1492-RTS2LN	12-48	1492-WD4PSS	12-22		
1492-RTS2LP	12-48	1492-WD4SS	12-32		
1492-SJ5-10	12-150	1492-WDG4P	12-23		
1492-SJ6-10	12-150	1492-WDG4PSS	12-23		
1492-SJ8-10	12-150	1492-WD6	12-13		
1492-SJFB8-10	12-150	1492-WFB10	12-70		
1492-SJM5-10	12-150	1492-WFB1024	12-70		
1492-SJMD5-12	12-150	1492-WFB10250	12-70		
1492-SJT5-20-B	12-150	1492-WFB10HD	12-55, 12-69		
1492-SJT5-20-R	12-150	1492-WFB4	12-24		
1492-SM5X12	12-155	1492-WFB424	12-24		
1492-SM5X5	12-155	1492-WFB4250	12-24		
1492-SM5X9	12-155	1492-WG10	12-18		
1492-SM6X12	12-155	1492-WG10S	12-17		
1492-SM6X9	12-155	1492-WG16	12-18		
1492-SM8X12	12-155	1492-WG35	12-18		
1492-SM8X9	12-155	1492-WG4	12-17		
1492-SMN81	12-155	1492-WG6	12-17		
1492-SMN83	12-155	1492-WKD3	12-19		
1492-SP3	12-149	1492-WKD3TP	12-19		
1492-SPD3	12-149	1492-WKD6	12-19		
1492-TA285	12-151	1492-WLD10	12-20		
1492-TA40	12-151	1492-WLD10C	12-20		
1492-TA40L	12-151	1492-WM3	12-8		
1492-TC3	12-153	1492-WM4	12-8		
1492-TC3Q	12-153	1492-WMD1	12-9		
1492-TC4	12-153	1492-WMG3	12-9		
1492-TC4Q	12-153	1492-WMG4	12-9		
1492-TCD	12-153	1492-WR3	12-14		

Regulatory Approvals

Allen-Bradley Terminal Block, Circuit Protection, and Interface Module products generally have been designed to meet the requirements of one or more regulatory bodies. The following is a listing of regulatory agencies applicable to Allen-Bradley terminal block products. See the particular product description for information on specific approvals and ratings.



— Underwriters Laboratories (USA).



— UL recognized per Canadian Safety Standards.



— Canadian Standards Association (Canada). A block listed in this selection guide with “CSA” ratings has CSA certification.



— Most blocks listed in this selection guide meet the requirements of the Low Voltage Directive put forth by the European Union. Blocks have been tested per European Standard EN 60947-7-1 or EN 60947-7-2. Circuit breakers have been tested to EN 60934.

IEC — International Electrotechnical Commission

A block listed in this selection guide with “IEC” ratings meets the requirements of IEC 947-7-1 or IEC 947-7-2

EEx e — Increased Safety

A block listed in this selection guide with “EEx e” ratings meets the increased safety requirements of IEC 79-0 and 79-7, as well as Cenelec standards EN 50 014 and EN 50 019, as an Ex component for Class 1, Zone 1 Hazardous Locations.

The Allen-Bradley Line of IEC Terminal Blocks . . . International Products for a Worldwide Marketplace

Allen-Bradley's Bulletin 1492–W line of internationally approved IEC style terminal blocks offer a wide range of features and benefits ideally suited for many industrial applications. The 1492–W line has been designed to meet the tough requirements of almost every industrial application. Functional, internationally approved, finger-safe and cost effective — Allen-Bradley's 1492–W line.

Products Available in the 1492–W Line

Our family of IEC terminal blocks consists of many different types of blocks, from general feed-through terminal blocks for control wiring, to specialty blocks for grounding and isolating. We even offer thermocouple terminal blocks, specifically designed for temperature dependent process control applications.

Products offered within the 1492–W line include:

- **Feed-Through Blocks**, capable of accommodating #22–3/0 AWG (0.5-70 mm²) wire
- **Grounding Blocks** for connecting a given circuit to a ground
- **Mini Blocks** for applications where panel space is at a premium
- **Two Level Blocks** which double circuit wiring density
- **Multi-Conductor Blocks** which allow splitting or joining of control circuits
- **Three Level Sensor Blocks** for coordination of three wire sensor groups
- **Isolation Blocks** for circuit isolation during testing and troubleshooting
- **Fuse Blocks**, with and without blown fuse indication, for easily integrated overcurrent protection
- **Electrical Component Blocks** which allow the insertion of fixed components into control circuits. Available components include resistors, diodes, surge suppression circuits and shunt bars
- **Return Blocks** which have both terminations on the same side of the terminal block allowing the rail to be mounted next to the wall of an enclosure
- **Plug-In Style Blocks** which allow the insertion of removable plugs into control circuits. Available plugs include a Disconnect Plug, a Fuse Plug, and a Component Plug which accommodate various electrical components.
- **Installation Blocks** for space saving distribution of phase, neutral, and ground conductors in single phase circuits
- **Thermocouple Terminal Blocks** (Types E, J, K, T) for temperature control applications
- A wide variety of **Snap-In Markers** for individual or group circuit identification
- Multi-Pole **Center Jumpers** which provide a convenient method of commoning control circuits

Materials and Design Features

The 1492–W line is specially designed for safety, installation ease, and ruggedness. Features using these design criteria include the following:

- Nickel plated terminals and stainless steel screws for superior corrosion resistance
- High copper content copper-alloy for excellent conductivity
- Four-sided funnel wire guides for easy wire insertion
- Finger-safe housings to prevent accidental contact with “live” circuits
- International approvals for worldwide use
- DIN rail (199–DR1) mountability allowing terminal blocks to be placed on the same channel as contactors, starters, relays, and other DIN rail mounted control devices
- Self-extinguishing, polyamide 6.6 housing material with UL 94–V2 flammability rating
- Backed out screws for fast wiring
- CE mark for use in the European Union

Bulletin 1492
IEC Terminal Blocks
Mini Blocks

1492-WM3

1492-WM4

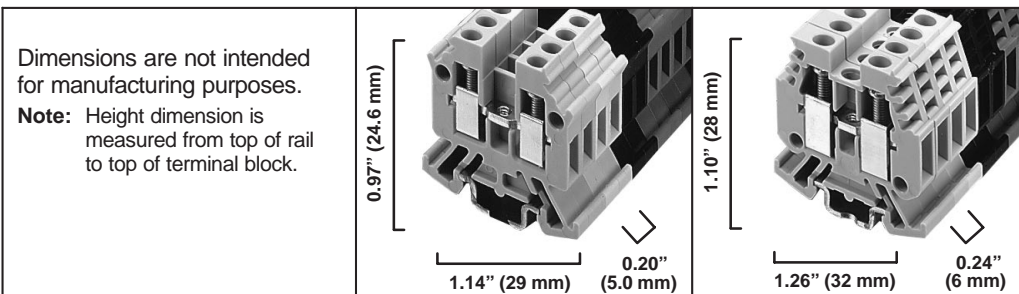

Dimensions are not intended for manufacturing purposes.
Note: Height dimension is measured from top of rail to top of terminal block.

Specifications		<i>Single circuit mini-terminal block.</i>			<i>Single circuit mini-terminal block.</i>		
Approvals (See Page 12-6)			CSA	IEC		CSA	IEC
Voltage Rating		300V AC/DC	300V AC/DC	500V AC/DC	300V AC/DC	300V AC/DC	500V AC/DC
Maximum Current		15A	15A	24A	20A	20A	32A
Wire Range (Rated Cross Section)		#22-#14 AWG	#22-#14 AWG	0.5-2.5 mm ²	#22-#12 AWG	#22-#12 AWG	0.5-4 mm ²
Wire Strip Length		0.24" (6 mm)			0.39" (10 mm)		
Recommended Tightening Torque		4.2-4.6 lb.-in. (0.5 Nm)			5.0-5.6 lb.-in. (0.6 Nm)		
Density		61 pcs./ft. (200/m)			50 pcs./ft. (166/m)		
Insulation Temperature Range		-40°C to +90°C			-40°C to +90°C		
Terminal Blocks		Catalog No.	Pcs./Pkg.	*	Catalog No.	Pcs./Pkg.	*
Color:	Gray	1492-WM3	50		1492-WM4	50	
	Red	1492-WM3-RE	50		1492-WM4-RE	50	
	Blue	1492-WM3-B	50		1492-WM4-B	50	
	Black	1492-WM3-BL	50		1492-WM4-BL	50	
	Green	1492-WM3-G	50		1492-WM4-G	50	
	Yellow	1492-WM3-Y	50		1492-WM4-Y	50	
	Orange	1492-WM3-OR	50		1492-WM4-OR	50	
Accessories		Catalog No.	Pcs./Pkg.	*	Catalog No.	Pcs./Pkg.	*
Mounting Rails: (Details Page 12-143) 1 M Sym. Mini DIN (Steel)		1492-DR3	5		1492-DR3	5	
End Barrier: (Details Page 12-147)		1492-EBM3	50		1492-EBM4	50	
End Anchors: (Details Page 12-146) Mini DIN Rail — Normal Duty		1492-EA15	50		1492-EA15	50	
Jumpers: (Details Page 12-150) Side Jumper — 10 Pole Insulated		1492-SJM5-10	10		1492-SJ6-10	10	
Center Jumper — 10 Pole		1492-CJM5-10	10		1492-CJD6-10	10	
Center Jumper — 3 Pole		—	—		1492-CJD6-3	10	
Center Jumper — 2 Pole		—	—		1492-CJD6-2	10	
Center Jumper Link		1492-CJL5	10		1492-CJL6	10	
Other Accessories: Partition Plate		1492-PPM3	50		1492-PPM3	50	
Test Plug		—	—		1492-TP28	10	
Test Plug Adapter		1492-TA285	10		1492-TA40	10	
Electrical Warning Plate (4 Pole)		—	—		1492-EWP6-4	10	
Marking Systems: (See Page 12-155)		1492-SM5X5	5		1492-SM6X9	5	

	1492-WMD1				1492-WMG3			1492-WMG4		
Dimensions are not intended for manufacturing purposes. Note: Height dimension is measured from top of rail to top of terminal block.										
	Two circuit mini-terminal block.				Single circuit mini-grounding terminal block.			Single circuit mini-grounding terminal block.		
Approvals (See Page 12-6)										
Voltage Rating	300V AC/DC				—			—		
Maximum Current	15A				Grounding			Grounding		
Wire Range (Rated Cross Section)	#22-#16 AWG				#14 AWG (2.5 mm ²)			#22-#12 AWG		
Wire Strip Length	0.35" (9 mm)				0.31" (8 mm)			0.39" (10 mm)		
Recommended Tightening Torque	4.2-4.6 lb.-in. (0.5 Nm)				6.2 lb.-in. (0.7 Nm)			5.3 lb.-in. (0.6 Nm)		
Density	61 pcs./ft. (200/m)				50 pcs./ft. (166/m)			50 pcs./ft. (166/m)		
Insulation Temperature Range	-40°C to +90°C				—			-40°C to +90°C		
Terminal Blocks	Catalog No.	Pcs./Pkg.	*	Catalog No.	Pcs./Pkg.	*	Catalog No.	Pcs./Pkg.	*	
Color:	Gray	1492-WMD1	50	—	—	—	1492-WMG4	10	—	
	Red	1492-WMD1-RE	50	—	—	—	—	—	—	
	Blue	1492-WMD1-B	50	—	—	—	—	—	—	
	Black	1492-WMD1-BL	50	—	—	—	—	—	—	
	Green	1492-WMD1-G	50	—	—	—	—	—	—	
	Yellow	1492-WMD1-Y	50	—	—	—	—	—	—	
	Orange	1492-WMD1-OR	50	—	—	—	—	—	—	
	White	1492-WMD1-W	50	—	—	—	—	—	—	
Accessories	Catalog No.	Pcs./Pkg.	*	Catalog No.	Pcs./Pkg.	*	Catalog No.	Pcs./Pkg.	*	
Mounting Rails: (Details Page 12-143) 1 M Sym. Mini DIN (Steel)	1492-DR3	5	—	1492-DR3	5	—	1492-DR3	5	—	
End Barrier: (Details Page 12-147)	1492-EBMD1	50	—	—	—	—	—	—	—	
End Anchors: (Details Page 12-146) Mini DIN Rail — Normal Duty	1492-EA15	50	—	—	—	—	1492-EA15	50	—	
Jumpers: (Details Page 12-150) Side Jumper — 12 Pole Insulated	1492-SJMD5-12	10	—	—	—	—	—	—	—	
Center Jumper — 10 Pole	—	—	—	—	—	—	—	—	—	
Center Jumper — 3 Pole	—	—	—	—	—	—	—	—	—	
Center Jumper — 2 Pole	—	—	—	—	—	—	—	—	—	
Center Jumper Link	—	—	—	—	—	—	—	—	—	
Other Accessories Partition Plate	1492-PPMD1	50	—	1492-PPM3	50	—	1492-PPM3	50	—	
Test Plug	—	—	—	—	—	—	—	—	—	
Test Plug Adapter	—	—	—	—	—	—	—	—	—	
Electrical Warning Plate (4 Pole)	—	—	—	—	—	—	—	—	—	
Marking Systems: (See Page 12-155)	1492-SM5X5	5	—	—	—	—	1492-SM6X9	5	—	

IEC Terminal Blocks

Standard Feed-Through Blocks

1492-W3

1492-W4

1492-W6

Dimensions are not intended for manufacturing purposes.

Note: Height dimension is measured from top of rail to top of terminal block.

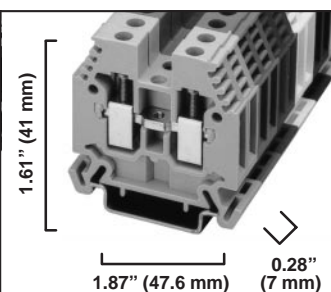
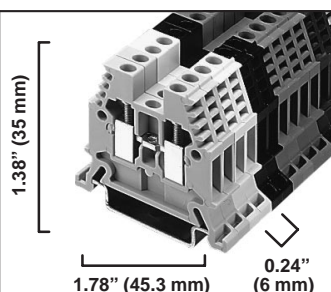
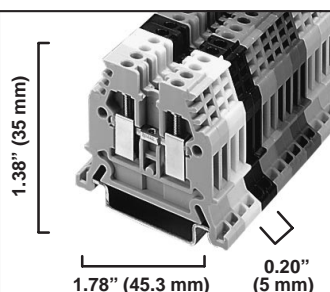

Specifications

	Single circuit terminal block.			Single circuit terminal block.			Single circuit terminal block.		
Approvals (See Page 12-6)		CSA	IEC		CSA	IEC		CSA	IEC
Voltage Rating	600V AC/DC	600V AC/DC	800V AC/DC	600V AC/DC	600V AC/DC	800V AC/DC	600V AC/DC	600V AC/DC	800V AC/DC
Maximum Current	20A	20A	24A	30A	30A	32A	40A	40A	41A
Wire Range (Rated Cross Section)	#22-#14 AWG	#22-#14 AWG	0.5-2.5 mm ²	#22-#10 AWG	#22-#10 AWG	0.5-4 mm ²	#22-#10 AWG	#22-#10 AWG	0.5-6 mm ²
Wire Strip Length	0.39" (10 mm)			0.35" (9 mm)			0.47" (12 mm)		
Recommended Tightening Torque	5.0-5.6 lb.-in. (0.6 Nm)			5.0-5.6 lb.-in. (0.6 Nm)			5.6-6.8 lb.-in. (0.7 Nm)		
Density	61 pcs./ft. (200/m)			50 pcs./ft. (166/m)			43 pcs./ft. (142/m)		
Insulation Temperature Range	-40°C to +90°C			-40°C to +90°C			-40°C to +90°C		

Terminal Blocks

	Catalog No.	Pcs./Pkg.	*	Catalog No.	Pcs./Pkg.	*	Catalog No.	Pcs./Pkg.	*
Color:	Gray	1492-W3	50		1492-W4	50		1492-W6	50
	Red	1492-W3-RE	50		1492-W4-RE	50		1492-W6-RE	50
	Blue	1492-W3-B	50		1492-W4-B	50		1492-W6-B	50
	Black	1492-W3-BL	50		1492-W4-BL	50		1492-W6-BL	50
	Green	1492-W3-G	50		1492-W4-G	50		1492-W6-G	50
	Yellow	1492-W3-Y	50		1492-W4-Y	50		1492-W6-Y	50
	Orange	1492-W3-OR	50		1492-W4-OR	50		1492-W6-OR	50
	White	1492-W3-W	50		1492-W4-W	50		1492-W6-W	50

Accessories

	Catalog No.	Pcs./Pkg.	*	Catalog No.	Pcs./Pkg.	*	Catalog No.	Pcs./Pkg.	*
Mounting Rails: (Details Page 12-143)									
1 M Symmetrical DIN (Steel)	199-DR1	10		199-DR1	10		199-DR1	10	
1 M Symmetrical DIN (Aluminum)	1492-DR5	10		1492-DR5	10		1492-DR5	10	
1 M Hi-Rise Sym. DIN (Aluminum)	1492-DR6	2		1492-DR6	2		1492-DR6	2	
1 M Angled Hi-Rise Sym. DIN (Steel)	1492-DR7	2		1492-DR7	2		1492-DR7	2	
End Barrier: (Details Page 12-147)	1492-EB3	50		1492-EB3	50		1492-EB10	50	
End Anchors: (Details Page 12-146)									
DIN Rail — Normal Duty	1492-EA35	50		1492-EA35	50		1492-EA35	50	
DIN Rail — Heavy Duty	1492-EAH35	10		1492-EAH35	10		1492-EAH35	10	
Jumpers: (Details Page 12-150)									
Side Jumper — 10 Pole Insulated	1492-SJ5-10	10		1492-SJ6-10	10		—	—	
Center Jumper — 10 Pole	1492-CJ5-10	10		1492-CJ6-10	10		1492-CJ7-10	10	
Center Jumper — 3 Pole	1492-CJ5-3	10		1492-CJ6-3	10		1492-CJ7-3	10	
Center Jumper — 2 Pole	1492-CJ5-2	10		1492-CJ6-2	10		1492-CJ7-2	10	
Center Jumper Link	1492-CJL5	10		1492-CJL6	10		1492-CJL7	10	
Center Jumper Cover	1492-CJCW5	10		1492-CJCW6	10		1492-CJCW6	10	
Other Accessories:									
Partition Plate	1492-PP3	50		1492-PP3	50		1492-PP10	50	
Separation Plate	1492-SP3	50		1492-SP3	50		—	—	
Test Plug	—	—		1492-TP28	10		1492-TP28	10	
Test Plug Adapter	1492-TA285	10		1492-TA40	10		1492-TA40	10	
Electrical Warning Plate (4 Pole)	1492-EWP5-4	10		1492-EWP6-4	10		1492-EWP7-4	10	
Group Marking Carrier	1492-GM35	10		1492-GM35	10		1492-GM35	10	
Marking Systems: (See Page 12-155)	1492-SM5X9	5		1492-SM6X12	5		1492-SM6X12	5	

1492-W10

1492-W16S

1492-W16

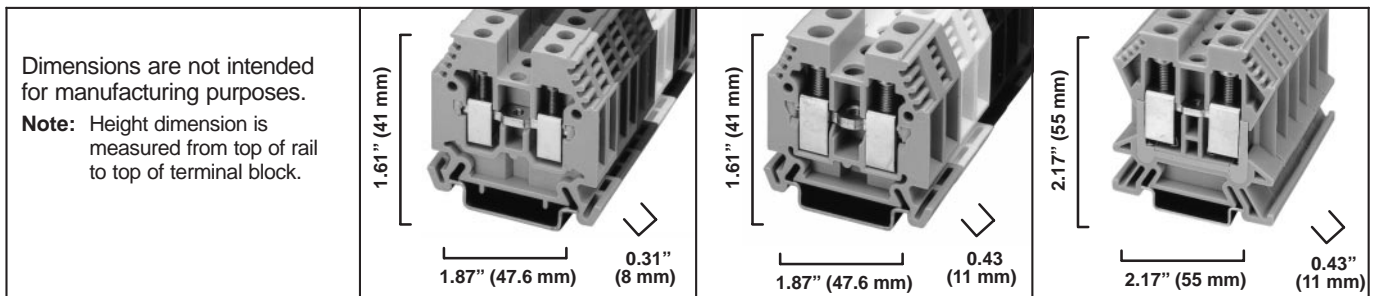

Specifications		<i>Single circuit terminal block.</i>			<i>Single circuit terminal block.</i>			<i>Single circuit terminal block.</i>		
Approvals (See Page 12-6)			CSA	IEC		CSA	IEC		CSA	IEC
Voltage Rating		600V AC/DC	600V AC/DC	800V AC/DC	600V AC/DC	600V AC/DC	800V AC/DC	600V AC/DC	600V AC/DC	750V AC/DC
Maximum Current		50A	50A	57A	85A	85A	76A	70A	105A	85A
Wire Range (Rated Cross Section)		#22-#8 AWG	#22-#8 AWG	0.5-10 mm ²	#14-#4 AWG	#14-#4 AWG	2.5-16 mm ²	#14-#4 AWG	#14-#4 AWG	1.5-16 mm ²
Wire Strip Length		0.51" (13 mm)			0.51" (13 mm)			0.51" (13 mm)		
Recommended Tightening Torque		12.2-13.4 lb.-in. (1.4 Nm)			18-20 lb.-in. (2.1 Nm)			22.1 lb.-in. (2.5 Nm)		
Density		38 pcs./ft. (125/m)			27 pcs./ft. (90/m)			27 pcs./ft. (90/m)		
Insulation Temperature Range		-40°C to +90°C			-40°C to +90°C			-40°C to +90°C		
Terminal Blocks	Catalog No.	Pcs./ Pkg.	*	Catalog No.	Pcs./ Pkg.	*	Catalog No.	Pcs./ Pkg.	*	
Color:	Gray	1492-W10	50		1492-W16S	50		1492-W16	50	
	Red	1492-W10-RE	50		1492-W16S-RE	50	—	—	—	
	Blue	1492-W10-B	50		1492-W16S-B	50	—	—	—	
	Black	1492-W10-BL	50		1492-W16S-BL	50	—	—	—	
	Green	1492-W10-G	50		1492-W16S-G	50	—	—	—	
	Yellow	1492-W10-Y	50		1492-W16S-Y	50	1492-W16-Y	50	—	
	Orange	1492-W10-OR	50		1492-W16S-OR	50	—	—	—	
	White	1492-W10-W	50		1492-W16S-W	50	—	—	—	
Accessories	Catalog No.	Pcs./ Pkg.	*	Catalog No.	Pcs./ Pkg.	*	Catalog No.	Pcs./ Pkg.	*	
Mounting Rails: (Details Page 12-143) 1 M Symmetrical DIN (Steel)	199-DR1	10		199-DR1	10		199-DR1	10		
1 M Symmetrical DIN (Aluminum)	1492-DR5	10		1492-DR5	10		1492-DR5	10		
1 M Hi-Rise Sym. DIN (Aluminum)	1492-DR6	2		1492-DR6	2		1492-DR6	2		
1 M Angled Hi-Rise Sym. DIN (Steel)	1492-DR7	2		1492-DR7	2		1492-DR7	2		
End Barrier: (Details Page 12-147)	1492-EB10	50		1492-EB10	50		1492-EB16	50		
End Anchors: (Details Page 12-146) DIN Rail — Normal Duty	1492-EA35	50		1492-EA35	50		1492-EA35	50		
DIN Rail — Heavy Duty	1492-EAH35	10		1492-EAH35	10		1492-EAH35	10		
Jumpers: (Details Page 12-150) Side Jumper — 10 Pole Insulated	1492-SJ8-10	10		—	—		—	—		
Center Jumper — 10 Pole	1492-CJ8-10	10		1492-CJS11-10	10		1492-CJ11-10	10		
Center Jumper — 5 Pole	—	—		—	—		1492-CJ11-5	10		
Center Jumper — 4 Pole	—	—		—	—		1492-CJ11-4	10		
Center Jumper — 3 Pole	1492-CJ8-3	10		1492-CJS11-3	10		—	—		
Center Jumper — 2 Pole	1492-CJ8-2	10		1492-CJS11-2	10		—	—		
Center Jumper Link	1492-CJL8	10		—	—		—	—		
Center Jumper Cover	1492-CJCW6	10		—	—		—	—		
Other Accessories: Partition Plate	1492-PP10	50		1492-PP10	50		1492-PP16	50		
Test Plug	1492-TP28	10		—	—		—	—		
Test Plug Adapter	1492-TA40	10		1492-TA40L	10		—	—		
Electrical Warning Plate (4 Pole)	1492-EWP8-4	10		1492-EWP11-4	10		1492-EWP11-4	10		
Group Marking Carrier	1492-GM35	10		1492-GM35	10		1492-GM35	10		
Marking Systems: (See Page 12-155)	1492-SM8X12	5		1492-SM6X12	5		1492-SM6X12	5		

IEC Terminal Blocks

Standard Feed-Through Blocks

1492-W35

1492-W70

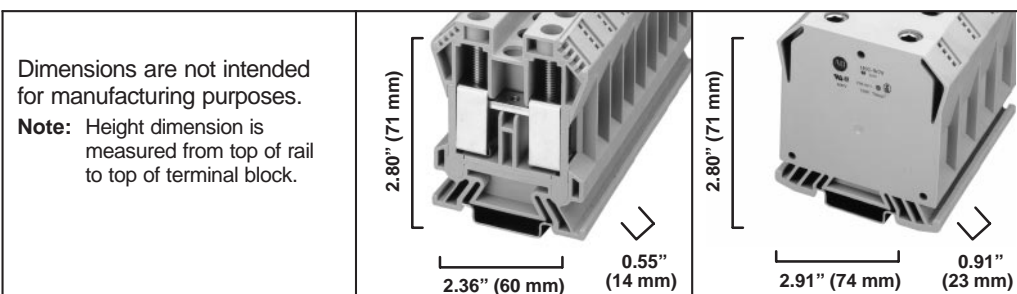

Dimensions are not intended for manufacturing purposes.

Note: Height dimension is measured from top of rail to top of terminal block.

Specifications		<i>Single circuit terminal block.</i>			<i>Single circuit terminal block.</i>		
Approvals (See Page 12-6)			CSA	IEC		CSA	IEC
Voltage Rating		600V AC/DC	600V AC/DC	750V AC/DC	600V AC/DC	600V AC/DC	750V AC/DC
Maximum Current		125A	140A	138A	200A	310A	175A
Wire Range (Rated Cross Section)		#14-1/0 AWG	#14-1/0 AWG	2.5-35 mm ²	#4-3/0 AWG	#4-3/0 AWG	4-70 mm ²
Wire Strip Length		0.67" (17 mm)			1.02" (26 mm)		
Recommended Tightening Torque		22.1 lb.-in. (2.5 Nm)			132.8 lb.-in. (15 Nm)		
Density		21 pcs./ft. (71/m)			13 pcs./ft. (43/m)		
Insulation Temperature Range		-40°C to +90°C			-40°C to +90°C		
Terminal Blocks		Catalog No.	Pcs./Pkg.	*	Catalog No.	Pcs./Pkg.	*
Color:	Gray	1492-W35	10		1492-W70	5	
	Red	—	—		—	—	
	Blue	—	—		—	—	
	Black	—	—		—	—	
	Green	—	—		—	—	
	Yellow	1492-W35-Y	10		—	—	
	Orange	—	—		—	—	
Accessories		Catalog No.	Pcs./Pkg.	*	Catalog No.	Pcs./Pkg.	*
Mounting Rails: (Details Page 12-143)							
1 M Symmetrical DIN (Steel)		199-DR1	10		199-DR1	10	
1 M Symmetrical DIN (Aluminum)		1492-DR5	10		1492-DR5	10	
1 M Hi-Rise Sym. DIN (Aluminum)		1492-DR6	2		1492-DR6	2	
1 M Angled Hi-Rise Sym. DIN (Steel)		1492-DR7	2		1492-DR7	2	
End Barrier: (Details Page 12-147)		1492-EB35	25		Not Required	—	
End Anchors: (Details Page 12-146)							
DIN Rail — Normal Duty		1492-EA35	50		—	—	
DIN Rail — Heavy Duty		1492-EAH35	10		1492-EAH35	10	
Jumpers: (Details Page 12-150)							
Side Jumper — 10 Pole Insulated		—	—		—	—	
Center Jumper — 10 Pole		—	—		—	—	
Center Jumper — 3 Pole		1492-CJ14-3	10		—	—	
Center Jumper — 2 Pole		1492-CJ14-2	10		—	—	
Center Jumper Link		—	—		—	—	
Other Accessories:							
Partition Plate		1492-PP35	25		—	—	
Test Plug		—	—		—	—	
Test Plug Adapter		—	—		—	—	
Electrical Warning Plate (4 Pole)		1492-EWP14-4	10		—	—	
Group Marking Carrier		1492-GM35	10		1492-GM35	10	
Marking Systems: (See Page 12-155)		1492-SM6X12	5		1492-SM6X12	5	

1492-WD3

1492-WD4

1492-WD6

Dimensions are not intended for manufacturing purposes. Note: Height dimension is measured from top of rail to top of terminal block.									
	Two circuit terminal block.			Two circuit terminal block.			Two circuit terminal block.		
Approvals (See Page 12-6)		CSA	IEC		CSA	IEC		CSA	IEC
Voltage Rating	300V AC/DC	300V AC/DC	500V AC/DC	300V AC/DC	300V AC/DC	500V AC/DC	300V AC/DC	300V AC/DC	500V AC/DC
Maximum Current	15A	15A	24A	20A	20A	32A	50A	55A	41A
Wire Range (Rated Cross Section)	#22-#14 AWG	#22-#14 AWG	0.5-2.5 mm ²	#22-#12 AWG	#22-#12 AWG	0.5-4 mm ²	#18-#8 AWG	#18-#8 AWG	0.5-6 mm ²
Wire Strip Length	0.39" (10 mm)			0.39" (10 mm)			0.35" (9 mm)		
Recommended Tightening Torque	5.0-5.6 lb.-in. (0.6 Nm)			5.0-5.6 lb.-in. (0.6 Nm)			6.2 lb.-in. (0.7 Nm)		
Density	60 pcs./ft. (197/m)			50 pcs./ft. (166/m)			43 pcs./ft. (142/m)		
Insulation Temperature Range	-40°C to +90°C			-40°C to +90°C			-40°C to +90°C		
Terminal Blocks	Catalog No.	Pcs./Pkg.	*	Catalog No.	Pcs./Pkg.	*	Catalog No.	Pcs./Pkg.	*
Color:	Gray	1492-WD3	50	*	1492-WD4	50	*	1492-WD6	20
	Red	1492-WD3-RE	50	*	1492-WD4-RE	50	*	—	—
	Blue	1492-WD3-B	50	*	1492-WD4-B	50	*	—	—
	Black	1492-WD3-BL	50	*	1492-WD4-BL	50	*	—	—
	Green	1492-WD3-G	50	*	1492-WD4-G	50	*	—	—
	Yellow	1492-WD3-Y	50	*	1492-WD4-Y	50	*	—	—
	Orange	1492-WD3-OR	50	*	1492-WD4-OR	50	*	—	—
Accessories	Catalog No.	Pcs./Pkg.	*	Catalog No.	Pcs./Pkg.	*	Catalog No.	Pcs./Pkg.	*
Mounting Rails: (Details Page 12-143) 1 M Symmetrical DIN (Steel)	199-DR1	10		199-DR1	10		199-DR1	10	
1 M Symmetrical DIN (Aluminum)	1492-DR5	10		1492-DR5	10		1492-DR5	10	
1 M Hi-Rise Sym. DIN (Aluminum)	1492-DR6	2		1492-DR6	2		1492-DR6	2	
1 M Angled Hi-Rise Sym. DIN (Steel)	1492-DR7	2		1492-DR7	2		1492-DR7	2	
End Barrier: (Details Page 12-147)	1492-EBD3	50		1492-EBD3	50		1492-EBD6	50	
End Anchors: (Details Page 12-146) DIN Rail — Normal Duty	1492-EA35	50		1492-EA35	50		1492-EA35	50	
DIN Rail — Heavy Duty	1492-EAH35	10		1492-EAH35	10		1492-EAH35	10	
Jumpers: (Details Page 12-150) Side Jumper — 10 Pole Insulated	1492-SJ5-10	10		1492-SJ6-10	10		—	—	
Center Jumper — 10 Pole	1492-CJD5-10	10		1492-CJD6-10	10		1492-CJ7-10	10	
Center Jumper — 3 Pole	1492-CJD5-3	10		1492-CJD6-3	10		1492-CJ7-3	10	
Center Jumper — 2 Pole	1492-CJD5-2	10		1492-CJD6-2	10		1492-CJ7-2	10	
Center Jumper Link	1492-CJL5	10		1492-CJL6	—		1492-CJL7	10	
Other Accessories: Partition Plate	1492-PPD3	50		1492-PPD3	50		1492-PPD6	50	
Separation Plate	1492-SPD3	50		1492-SPD3	50		—	—	
Test Plug	—	—		1492-TP28	10		1492-TP28	10	
Test Plug Adapter	1492-TA285	10		1492-TA40	10		1492-TA40	10	
Electrical Warning Plate (4 Pole)	1492-EWP5-4	10		1492-EWP6-4	10		1492-EWP7-4	10	
Group Marking Carrier	1492-GM35	10		1492-GM35	10		1492-GM35	5	
Marking Systems: (See Page 12-155)	1492-SM5X9	5		1492-SM6X9	5		1492-SM6X12	5	

IEC Terminal Blocks

Specialty Feed-Through Blocks

1492-W3TW

1492-WR3

Dimensions are not intended for manufacturing purposes.

Note: Height dimension is measured from top of rail to top of terminal block.

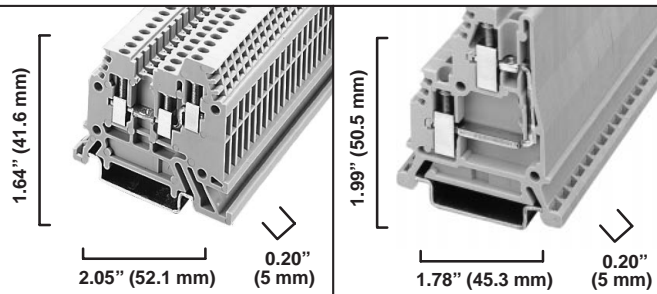

Specifications		Single circuit three-conductor terminal block.			Single circuit terminal block with terminals on common side.		
Approvals (See Page 12-6)			CSA	IEC		CSA	IEC
Voltage Rating		600V AC/DC	600V AC/DC	800V AC/DC	300V AC/DC	300V AC/DC	500V AC/DC
Maximum Current		15A	15A	24A	15A	15A	24A
Wire Range (Rated Cross Section)		#22-#14 AWG	#22-#14 AWG	0.5-2.5 mm ²	#22-#14 AWG	#22-#14 AWG	0.5-2.5 mm ²
Wire Strip Length		0.35" (9 mm)			0.39" (10 mm)		
Recommended Tightening Torque		4.2-4.6 lb.-in. (0.5 Nm)			5.0-5.6 lb.-in. (0.6 Nm)		
Density		61 pcs./ft. (200/m)			61 pcs./ft. (200/m)		
Insulation Temperature Range		-40°C to +90°C			-40°C to +90°C		
Terminal Blocks		Catalog No.	Pcs./Pkg.	*	Catalog No.	Pcs./Pkg.	*
Color:	Gray	1492-W3TW	50		1492-WR3	50	
	Red	1492-W3TW-RE	50		—	—	
	Blue	1492-W3TW-B	50		—	—	
	Black	1492-W3TW-BL	50		—	—	
	Green	1492-W3TW-G	50		—	—	
	Yellow	1492-W3TW-Y	50		—	—	
	Orange	1492-W3TW-OR	50		—	—	
	White	1492-W3TW-W	50		—	—	
Accessories		Catalog No.	Pcs./Pkg.	*	Catalog No.	Pcs./Pkg.	*
Mounting Rails: (Details Page 12-143)	1 M Symmetrical DIN (Steel)	199-DR1	10		199-DR1	10	
	1 M Symmetrical DIN (Aluminum)	1492-DR5	10		1492-DR5	10	
	1 M Hi-Rise Sym. DIN (Aluminum)	1492-DR6	2		1492-DR6	2	
	1 M Angled Hi-Rise Sym. DIN (Steel)	1492-DR7	2		1492-DR7	2	
End Barrier: (Details Page 12-147)		1492-EB3TW	50		1492-EBR3	50	
End Anchors: (Details Page 12-146)	DIN Rail — Normal Duty	1492-EA35	50		1492-EA35	50	
	DIN Rail — Heavy Duty	1492-EAH35	10		1492-EAH35	10	
Jumpers: (Details Page 12-150)	Side Jumper — 10 Pole Insulated	1492-SJ5-10 ¹	10		1492-SJ5-10	10	
	Center Jumper — 10 Pole	1492-CJ5-10	10		1492-CJD5-10	10	
	Center Jumper — 3 Pole	1492-CJ5-3	10		1492-CJD5-3	10	
	Center Jumper — 2 Pole	1492-CJ5-2	10		1492-CJD5-2	10	
	Center Jumper Cover	1492-CJCW5	10		1492-CJCW5	10	
	Center Jumper Link	1492-CJL5	10		1492-CJL5	10	
Other Accessories:	Partition Plate	1492-PP10	50		1492-EBR3	50	
	End Cover ²	1492-EC3TW	10		—	—	
	Test Plug	—	—	—	—	—	—
	Test Plug Adapter	1492-TA285	10		1492-TA285	10	
	Electrical Warning Plate (4 Pole)	1492-EWP5-4	10		1492-EWP5-4	10	
	Group Marking Carrier	1492-GM35	10		1492-GM35	10	
Marking Systems: (See Page 12-155)		1492-SM5X9	5		1492-SM5X9	—	

¹ Use side jumpers on the single conductor side only.

² Provides IP2X Finger Safety when a W3 is mounted on open side of 1492-W3TW.

1492-WTF3

1492-WTF3LP

1492-WTF3LN

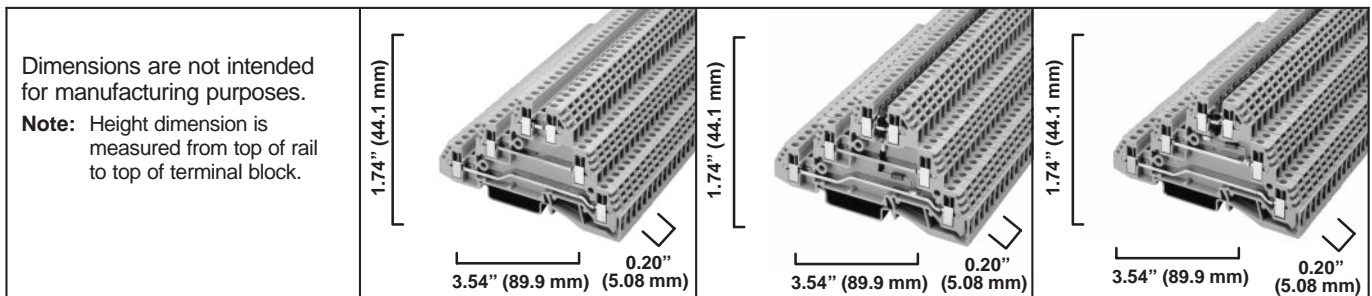

Dimensions are not intended for manufacturing purposes.
Note: Height dimension is measured from top of rail to top of terminal block.

Specifications	<i>Three circuit terminal block.</i>			<i>Three circuit terminal block with LED indicator for PNP devices.</i>			<i>Three circuit terminal block with LED indicator for NPN devices.</i>		
Approvals (See Page 12-6)		CSA	IEC		CSA	IEC		CSA	IEC
Voltage Rating	300V	300V	500V	300V	50V	500V	300V	50V	500V
Maximum Current	10A	10A	24A	10A	10A	24A	10A	10A	24A
Wire Range (Rated Cross Section)	#26-#14 AWG	#26-#14 AWG	0.5-2.5 mm ²	#26-#14 AWG	#26-#14 AWG	0.5-2.5 mm ²	#26-#14 AWG	#26-#14 AWG	0.5-2.5 mm ²
Leakage Current	—			2.69mA@50V			2.69mA@50V		
Wire Strip Length	0.31" (8 mm)			0.31" (8 mm)			0.31" (8 mm)		
Recommended Tightening Torque	4.2-4.6 lb.-in. (0.5 Nm)			4.2-4.6 lb.-in. (0.5 Nm)			4.2-4.6 lb.-in. (0.5 Nm)		
Density	60 pcs./ft. (197/m)			60 pcs./ft. (197/m)			60 pcs./ft. (197/m)		
Insulation Temperature Range	-40°C to +90°C			-40°C to +90°C			-40°C to +90°C		
Terminal Blocks	Catalog No.	Pcs./Pkg.	*	Catalog No.	Pcs./Pkg.	*	Catalog No.	Pcs./Pkg.	*
Terminal Block:	1492-WTF3	50		1492-WTF3LP	50		1492-WTF3LN	50	
Accessories	Catalog No.	Pcs./Pkg.	*	Catalog No.	Pcs./Pkg.	*	Catalog No.	Pcs./Pkg.	*
Mounting Rails: (Details Page 12-143)									
1 M Symmetrical DIN (Steel)	199-DR1	10		199-DR1	10		199-DR1	10	
1 M Symmetrical DIN (Aluminum)	1492-DR5	10		1492-DR5	10		1492-DR5	10	
1 M Hi-Rise Sym. DIN (Aluminum)	1492-DR6	2		1492-DR6	2		1492-DR6	2	
1 M Angled Hi-Rise Sym. DIN (Steel)	1492-DR7	2		1492-DR7	2		1492-DR7	2	
End Barrier: (Details Page 12-147)	1492-EBTF3	50		1492-EBTF3	50		1492-EBTF3	50	
End Anchors: (Details Page 12-146)									
DIN Rail — Normal Duty	1492-EA35	50		1492-EA35	50		1492-EA35	50	
DIN Rail — Heavy Duty	1492-EAH35	10		1492-EAH35	10		1492-EAH35	10	
Jumpers: (Details Page 12-150)									
Side — 20 Pole Insulated Red	1492-SJT5-20-R	10		1492-SJT5-20-R	10		1492-SJT5-20-R	10	
Side — 20 Pole Insulated Blue	1492-SJT5-20-B	10		1492-SJT5-20-B	10		1492-SJT5-20-B	10	
Center Jumper — 10 Pole	1492-CJT5-10	10		1492-CJT5-10	10		1492-CJT5-10	10	
Center Jumper — 1 meter long	1492-CJT5-1M	1		1492-CJT5-1M	1		1492-CJT5-1M	1	
Center Jumper Link	1492-CJL5	10		1492-CJL5	10		1492-CJL5	10	
Center Jumper Cover — Red	1492-CJCR5	10		1492-CJCR5	10		1492-CJCR5	10	
Center Jumper Cover — Blue	1492-CJCB5	10		1492-CJCB5	10		1492-CJCB5	10	
Other Accessories:									
Partition Plate	1492-PPTS3	50		1492-PPTS3	50		1492-PPTS3	50	
Test Plug Adapter	1492-TA285	10		1492-TA285	10		1492-TA285	10	
Electrical Warning Plate (4 Pole)	1492-EWP5-4	10		1492-EWP5-4	10		1492-EWP5-4	10	
Group Marking Carrier	1492-GM35	10		1492-GM35	10		1492-GM35	10	
Marking Systems: (See Page 12-155)	1492-SM5X9	5		1492-SM5X9	5		1492-SM5X9	5	

1492-WTS3

1492-WTS3LP

1492-WTS3LN

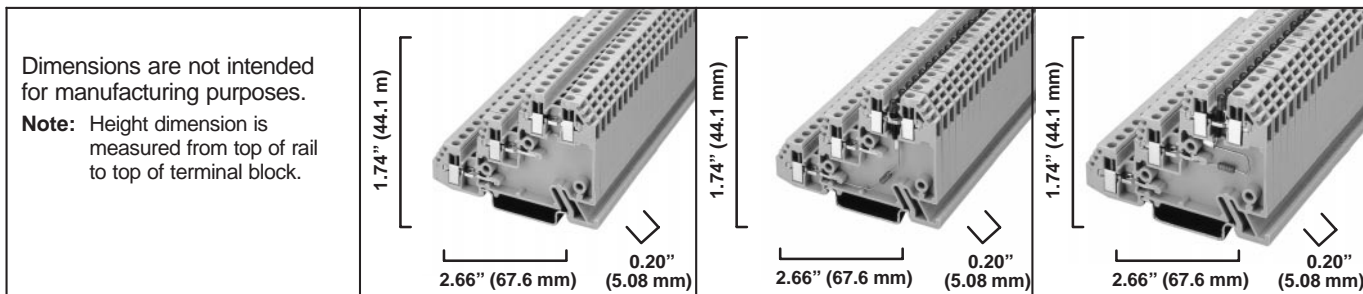

Dimensions are not intended for manufacturing purposes.
Note: Height dimension is measured from top of rail to top of terminal block.

Specifications	<i>Three level sensor block.</i>			<i>Three level sensor block with LED indicator for PNP devices.</i>			<i>Three level sensor block with LED indicator for NPN devices.</i>		
Approvals (See Page 12-6)		CSA	IEC		CSA	IEC		CSA	IEC
Voltage Rating	300V	300V	500V	300V	50V	500V	300V	50V	500V
Maximum Current	10A	10A	24A	10A	10A	24A	10A	10A	24A
Wire Range (Rated Cross Section)	#26-#14 AWG	#26-#14 AWG	0.5-2.5 mm ²	#26-#14 AWG	#26-#14 AWG	0.5-2.5 mm ²	#26-#14 AWG	#26-#14 AWG	0.5-2.5 mm ²
Leakage Current	—			2.69mA@50V			2.69mA@50V		
Wire Strip Length	0.31" (8 mm)			0.31" (8 mm)			0.31" (8 mm)		
Recommended Tightening Torque	4.2-4.6 lb.-in. (0.5 Nm)			4.2-4.6 lb.-in. (0.5 Nm)			4.2-4.6 lb.-in. (0.5 Nm)		
Density	60 pcs./ft. (197/m)			60 pcs./ft. (197/m)			60 pcs./ft. (197/m)		
Insulation Temperature Range	-40°C to +90°C			-40°C to +90°C			-40°C to +90°C		
Terminal Blocks	Catalog No.	Pcs./Pkg.	*	Catalog No.	Pcs./Pkg.	*	Catalog No.	Pcs./Pkg.	*
Terminal Block:	1492-WTS3	50		1492-WTS3LP	50		1492-WTS3LN	50	
Accessories	Catalog No.	Pcs./Pkg.	*	Catalog No.	Pcs./Pkg.	*	Catalog No.	Pcs./Pkg.	*
Mounting Rails: (Details Page 12-143) 1 M Symmetrical DIN (Steel)	199-DR1	10		199-DR1	10		199-DR1	10	
1 M Symmetrical DIN (Aluminum)	1492-DR5	10		1492-DR5	10		1492-DR5	10	
1 M Hi-Rise Sym. DIN (Aluminum)	1492-DR6	2		1492-DR6	2		1492-DR6	2	
1 M Angled Hi-Rise Sym. DIN (Steel)	1492-DR7	2		1492-DR7	2		1492-DR7	2	
End Barrier: (Details Page 12-147)	1492-EBTS3	50		1492-EBTS3	50		1492-EBTS3	50	
End Anchors: (Details Page 12-146) DIN Rail — Normal Duty	1492-EA35	50		1492-EA35	50		1492-EA35	50	
DIN Rail — Heavy Duty	1492-EAH35	10		1492-EAH35	10		1492-EAH35	10	
Jumpers: (Details Page 12-150) Side — 20 Pole Insulated Red	1492-SJT5-20-R	10		1492-SJT5-20-R	10		1492-SJT5-20-R	10	
Side — 20 Pole Insulated Blue	1492-SJT5-20-B	10		1492-SJT5-20-B	10		1492-SJT5-20-B	10	
Center Jumper — 10 Pole	1492-CJT5-10	10		1492-CJT5-10	10		1492-CJT5-10	10	
Center Jumper — 1 meter long	1492-CJT5-1M	1		1492-CJT5-1M	1		1492-CJT5-1M	1	
Center Jumper Link	1492-CJL5	10		1492-CJL5	10		1492-CJL5	10	
Center Jumper Cover — Red	1492-CJCR5	10		1492-CJCR5	10		1492-CJCR5	10	
Center Jumper Cover — Blue	1492-CJCB5	10		1492-CJCB5	10		1492-CJCB5	10	
Other Accessories: Partition Plate	1492-PPTS3	50		1492-PPTS3	50		1492-PPTS3	50	
Test Plug Adapter	1492-TA285	10		1492-TA285	10		1492-TA285	10	
Electrical Warning Plate (4 Pole)	1492-EWP5-4	10		1492-EWP5-4	10		1492-EWP5-4	10	
Group Marking Carrier	1492-GM35	10		1492-GM35	10		1492-GM35	10	
Marking Systems: (See Page 12-155)	1492-SM5X9	5		1492-SM5X9	5		1492-SM5X9	5	

1492-WG4

1492-WG6

1492-WG10S

Dimensions are not intended for manufacturing purposes. Note: Height dimension is measured from top of rail to top of terminal block.									
	Single circuit grounding terminal block.			Single circuit grounding terminal block.			Single circuit grounding terminal block.		
Approvals (See Page 12-6)		CSA	IEC		CSA	IEC		CSA	IEC
Voltage Rating	—	—	—	—	—	—	—	—	—
Maximum Current	Grounding			Grounding			Grounding		
Wire Range (Rated Cross Section)	#22-#12 AWG	#22-#12 AWG	4 mm ²	#22-#10 AWG	#22-#10 AWG	6 mm ²	#22-#8 AWG	#22-#8 AWG	10 mm ²
Wire Strip Length	0.43" (11 mm)			0.47" (12 mm)			0.43" (11 mm)		
Recommended Tightening Torque	5.6-6.8 lb.-in. (0.7 Nm)			5.6-6.8 lb.-in. (0.7 Nm)			7.1 lb.-in. (0.8 Nm)		
Density	50 pcs./ft. (166/m)			43 pcs./ft. (142/m)			38 pcs./ft. (125/m)		
Insulation Temperature Range	-40°C to +90°C			-40°C to +90°C			-40°C to +90°C		
Terminal Blocks	Catalog No.	Pcs./Pkg.	*	Catalog No.	Pcs./Pkg.	*	Catalog No.	Pcs./Pkg.	*
Terminal Block:	1492-WG4	50		1492-WG6	50		1492-WG10S	10	
Accessories	Catalog No.	Pcs./Pkg.	*	Catalog No.	Pcs./Pkg.	*	Catalog No.	Pcs./Pkg.	*
Mounting Rails: (Details Page 12-143) 1 M Symmetrical DIN (Steel)	199-DR1	10		199-DR1	10		199-DR1	10	
1 M Symmetrical DIN (Aluminum)	1492-DR5	10		1492-DR5	10		1492-DR5	10	
1 M Hi-Rise Sym. DIN (Aluminum)	1492-DR6	2		1492-DR6	2		1492-DR6	2	
1 M Angled Hi-Rise Sym. DIN (Steel)	1492-DR7	2		1492-DR7	2		1492-DR7	2	
End Barrier: (Details Page 12-147)	1492-EB3-Y	50		1492-EB10-Y	50		1492-EB10-Y	50	
End Anchors: (Details Page 12-146) DIN Rail — Normal Duty	1492-EA35	50		1492-EA35	50		1492-EA35	—	
DIN Rail — Heavy Duty	1492-EAH35	10		1492-EAH35	10		1492-EAH35	—	
Other Accessories: Group Marking Carrier	1492-GM35	10		1492-GM35	10		1492-GM35	10	
Marking Systems: (See Page 12-155)	1492-SM6X12	5		1492-SM6X12	5		1492-SM8X12	5	

Bulletin 1492
IEC Terminal Blocks
Grounding Blocks

1492-WG10

1492-WG16

1492-WG35

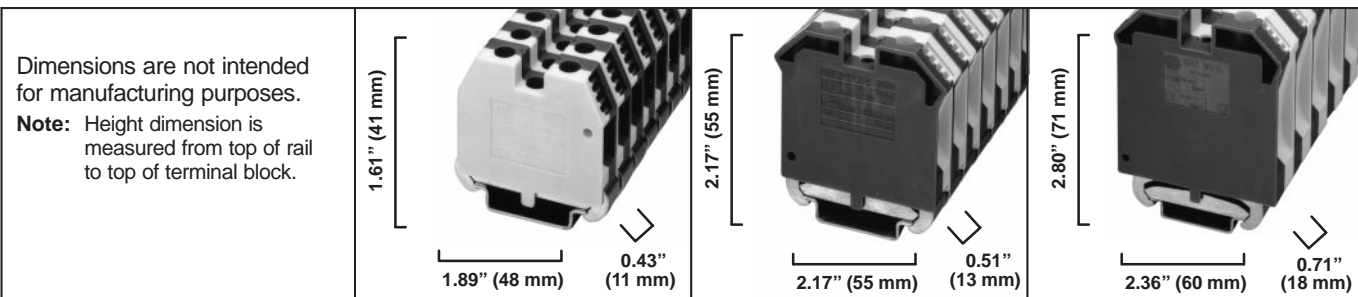

Specifications	Single circuit grounding terminal block.			Single circuit grounding terminal block.			Single circuit grounding terminal block.		
Approvals (See Page 12-6)		CSA	IEC		CSA	IEC		CSA	IEC
Voltage Rating	—	—	—	—	—	—	—	—	—
Maximum Current	Grounding			Grounding			Grounding		
Wire Range (Rated Cross Section)	#16-#6 AWG	#16-#6 AWG	10 mm ²	#10-#4 AWG	#10-#4 AWG	16 mm ²	#6-1/0 AWG	#6-1/0 AWG	35 mm ²
Wire Strip Length	0.47" (12 mm)			0.70" (18 mm)			0.83" (21 mm)		
Recommended Tightening Torque	15.9 lb.-in. (1.8 Nm)			22.1 lb.-in. (2.5 Nm)			44.3 lb.-in. (5.0 Nm)		
Density	27 pcs./ft. (90/m)			23 pcs./ft. (76/m)			16 pcs./ft. (55/m)		
Insulation Temperature Range	-40°C to +90°C			-40°C to +90°C			-40°C to +90°C		
Terminal Blocks	Catalog No.	Pcs./Pkg.	*	Catalog No.	Pcs./Pkg.	*	Catalog No.	Pcs./Pkg.	*
Terminal Block:	1492-WG10	10		1492-WG16	10		1492-WG35	10	
Accessories	Catalog No.	Pcs./Pkg.	*	Catalog No.	Pcs./Pkg.	*	Catalog No.	Pcs./Pkg.	*
Mounting Rails: (Details Page 12-143) 1 M Symmetrical DIN (Steel)	199-DR1	10		199-DR1	10		199-DR1	10	
1 M Symmetrical DIN (Aluminum)	1492-DR5	10		1492-DR5	10		1492-DR5	10	
1 M Hi-Rise Sym. DIN (Aluminum)	1492-DR6	2		1492-DR6	2		1492-DR6	2	
1 M Angled Hi-Rise Sym. DIN (Steel)	1492-DR7	2		1492-DR7	2		1492-DR7	2	
End Barrier: (Details Page 12-147)	Not Required	—		Not Required	—		Not Required	—	
End Anchors: (Details Page 12-146) DIN Rail — Normal Duty	Not Required	—		Not Required	—		Not Required	—	
DIN Rail — Heavy Duty	Not Required	—		Not Required	—		Not Required	—	
Other Accessories: Group Marking Carrier	1492-GM35	10		1492-GM35	10		1492-GM35	10	
Marking Systems: (See Page 12-155)	1492-SM6X12	5		1492-SM6X12	5		1492-SM6X12	5	

1492-WKD3

1492-WKD3TP

1492-WKD6

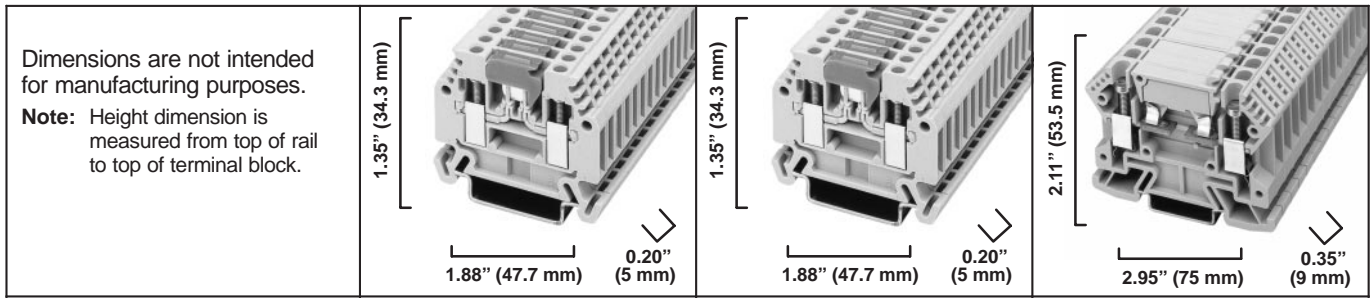

Dimensions are not intended for manufacturing purposes.
Note: Height dimension is measured from top of rail to top of terminal block.

Specifications									
<i>Knife style isolating terminal block.</i>									
<i>Knife style isolating terminal block with test plug screws.</i>									
<i>Knife style isolating terminal block.</i>									
Approvals (See Page 12-6)		CSA	IEC		CSA	IEC		CSA	IEC
Voltage Rating	600V AC/DC	600V AC/DC	800V AC/DC	300V AC/DC	300V AC/DC	800V AC/DC	600V AC/DC	600V AC/DC	800V AC/DC
Maximum Current	15A	15A	15A	15A	15A	15A	30A	30A	32A
Wire Range (Rated Cross Section)	#22-#14 AWG	#22-#14 AWG	0.5-2.5 mm ²	#22-#14 AWG	#22-#14 AWG	0.5-2.5 mm ²	#18-#10 AWG	#18-#10 AWG	0.5-6 mm ²
Wire Strip Length	0.35" (9 mm)			0.35" (9 mm)			0.55" (14 mm)		
Recommended Tightening Torque	5.0-5.6 lb.-in. (0.6 Nm)			5.0-5.6 lb.-in. (0.6 Nm)			7.1 lb.-in. (0.8 Nm)		
Density	61 pcs./ft. (200/m)			61 pcs./ft. (200/m)			33 pcs./ft. (111/m)		
Insulation Temperature Range	-40°C to +90°C			-40°C to +90°C			-40°C to +90°C		
Terminal Blocks	Catalog No.	Pcs./Pkg.	*	Catalog No.	Pcs./Pkg.	*	Catalog No.	Pcs./Pkg.	*
Color: Gray	1492-WKD3	50		1492-WKD3TP	50		1492-WKD6	20	
Black	—	—		—	—		—	—	
Accessories	Catalog No.	Pcs./Pkg.	*	Catalog No.	Pcs./Pkg.	*	Catalog No.	Pcs./Pkg.	*
Mounting Rails: (Details Page 12-143) 1 M Symmetrical DIN (Steel)	199-DR1	10		199-DR1	10		199-DR1	10	
1 M Symmetrical DIN (Aluminum)	1492-DR5	10		1492-DR5	10		1492-DR5	10	
1 M Hi-Rise Sym. DIN (Aluminum)	1492-DR6	2		1492-DR6	2		1492-DR6	2	
1 M Angled Hi-Rise Sym. DIN (Steel)	1492-DR7	2		1492-DR7	2		1492-DR7	2	
End Barrier: (Details Page 12-147)	1492-EBKD3	50		1492-EBKD3	50		1492-EBKD6	—	
End Anchors: (Details Page 12-146) DIN Rail — Normal Duty	1492-EA35	50		1492-EA35	50		1492-EA35	50	
DIN Rail — Heavy Duty	1492-EAH35	10		1492-EAH35	10		1492-EAH35	10	
Jumpers: (Details Page 12-150) Side Jumper — 10 Pole Insulated	1492-SJ5-10	10		1492-SJ5-10	10		—	—	
Side Jumper — 10 Pole Uninsulated	—	—		—	—		—	—	
Commoning Bus Bar	—	—		—	—		—	—	
Other Accessories: Partition Plate	1492-PPSL3	50		1492-PPSL3	50		—	—	
Test Plug	—	—		1492-TP15	10		—	—	
Group Marking Carrier	1492-GM35	10		1492-GM35	10		1492-GM35	10	
Marking Systems: (See Page 12-155)	1492-SM5X9	5		1492-SM5X9	5		1492-SM6X12	5	

Bulletin 1492
IEC Terminal Blocks
Isolation Blocks

1492-WLD10

1492-WLD10C

1492-H7

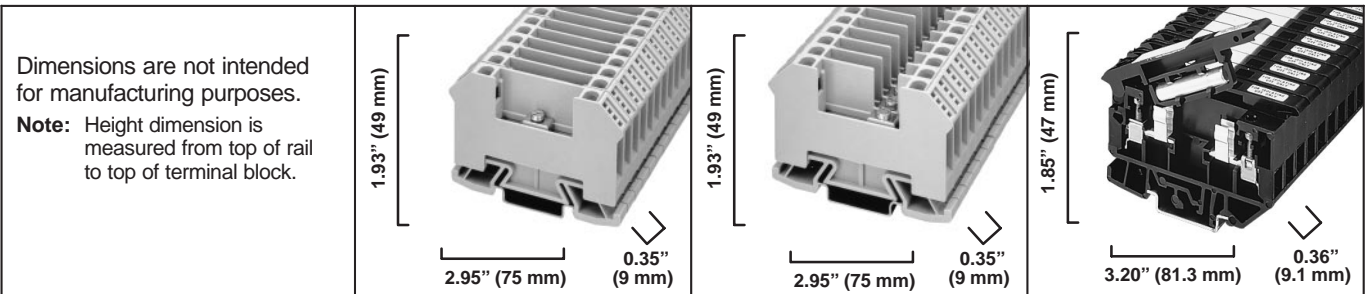

Specifications	Longitudinal style isolating terminal block.			Lateral isolating terminal block.			Handle style isolating terminal block.		
Approvals (See Page 12-6)	UL	CSA	IEC	UL	CSA	IEC	UL	CSA	IEC
Voltage Rating	600V AC/DC	600V AC/DC	380V AC/DC	600V AC/DC	600V AC/DC	800V AC/DC	300V AC/DC	300V AC/DC	500V AC/DC
Maximum Current	30A	30A	32A	30A	30A	32A	15A	15A	15A
Wire Range (Rated Cross Section)	#18-#8 AWG	#18-#8 AWG	0.5-10 mm ²	#18-#10 AWG	#18-#10 AWG	0.5-6 mm ²	#30-#12 AWG	#30-#12 AWG	0.05-4.0 mm ²
Wire Strip Length	0.55" (14 mm)			0.55" (14 mm)			0.38" (9.7 mm)		
Recommended Tightening Torque	7.1 lb.-in. (0.8 Nm)			7.1 lb.-in. (0.8 Nm)			3-7 lb.-in. (0.3-0.8 Nm)		
Density	33 pcs./ft. (111/m)			33 pcs./ft. (111/m)			33 pcs./ft. (109/m)		
Insulation Temperature Range	-40°C to +90°C			-40°C to +90°C			-40°C to +105°C		
Terminal Blocks	Catalog No.	Pcs./Pkg.	*	Catalog No.	Pcs./Pkg.	*	Catalog No.	Pcs./Pkg.	*
Color: Gray	1492-WLD10	20		1492-WLD10C	20		—	—	
Black	—	—		—	—		1492-H7	25	
Accessories	Catalog No.	Pcs./Pkg.	*	Catalog No.	Pcs./Pkg.	*	Catalog No.	Pcs./Pkg.	*
Mounting Rails: (Details Page 12-143) 1 M Symmetrical DIN (Steel)	199-DR1	10		199-DR1	10		199-DR1	10	
1 M Symmetrical DIN (Aluminum)	1492-DR5	10		1492-DR5	10		1492-DR5	10	
1 M Hi-Rise Sym. DIN (Aluminum)	1492-DR6	2		1492-DR6	2		1492-DR6	2	
1 M Angled Hi-Rise Sym. DIN (Steel)	1492-DR7	2		1492-DR7	2		1492-DR7	2	
End Barrier: (Details Page 12-147)	Not Required	—		1492-EBKD6	50		1492-N37	50	
End Anchors: (Details Page 12-146) DIN Rail — Normal Duty	1492-EA35	50		1492-EA35	50		1492-EA35	50	
DIN Rail — Heavy Duty	1492-EAH35	10		1492-EAH35	10		1492-EAH35	10	
Jumpers: (Details Page 12-150) Side Jumper — 10 Pole Insulated	—	—		—	—		—	—	
Side Jumper — 10 Pole Uninsulated	—	—		—	—		1492-N49	10	
Commoning Bus Bar	—	—		1492-CBB9-10	10		—	—	
Other Accessories: Partition Plate	—	—		—	—		—	—	
Test Plug	—	—		—	—		—	—	
Group Marking Carrier	1492-GM35	10		1492-GM35	10		1492-GM35	10	
Marking Systems: (See Page 12-155)	1492-SM6X12	5		1492-SM6X12	5		1492-SM8X12	5	

1492-W4P

1492-W4PTP

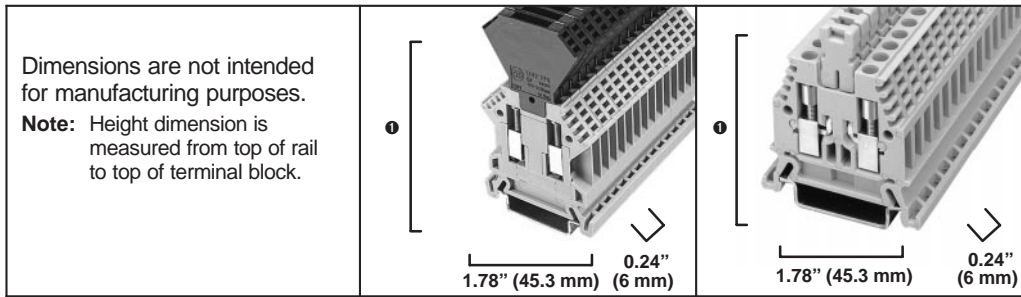

Specifications		<i>Pluggable terminal block.</i>			<i>Pluggable terminal block with test plug screws</i>		
Approvals (See Page 12-6)		CSA	IEC		CSA	IEC	
Voltage Rating	600V AC/DC	600V AC/DC	800V AC/DC	600V AC/DC	600V AC/DC	800V AC/DC	
Maximum Current	20A	20A	32A	20A	20A	32A	
Wire Range (Rated Cross Section)	#22-#12 AWG	#22-#12 AWG	0.5-2.5 mm ²	#22-#12 AWG	#22-#12 AWG	0.5-2.5 mm ²	
Wire Strip Length	0.35" (9 mm)			0.35" (9 mm)			
Recommended Tightening Torque	5.0-5.6 lb.-in. (0.6 Nm)			5.0-5.6 lb.-in. (0.6 Nm)			
Density	50 pcs./ft. (166/m)			50 pcs./ft. (166/m)			
Insulation Temperature Range	-40°C to +90°C			-40°C to +90°C			
Terminal Blocks	Catalog No.	Pcs./ Pkg.	*	Catalog No.	Pcs./ Pkg.	*	
Terminal Block:	1492-W4P	50		1492-W4PTP	50		
Inserts:	Disconnect Plug	1492-DP4	50	1492-DP4 (shown)	50		
	Component Plug	1492-CP4	50	1492-CP4	50		
	Fuse Plug	1492-FP4 (shown)	50	1492-FP4	50		
	Fuse Plug w/Led Blown Fuse Indication	1492-FP424	50	1492-FP424	50		
	Fuse Plug w/Neon Blown Fuse Indication	1492-FP4250	50	1492-FP4250	50		
Accessories	Catalog No.	Pcs./ Pkg.	*	Catalog No.	Pcs./ Pkg.	*	
Mounting Rails: (Details Page 12-143) 1 M Symmetrical DIN (Steel)	199-DR1	10		199-DR1	10		
1 M Symmetrical DIN (Aluminum)	1492-DR5	10		1492-DR5	10		
1 M Hi-Rise Sym. DIN (Aluminum)	1492-DR6	2		1492-DR6	2		
1 M Angled Hi-Rise Sym. DIN (Steel)	1492-DR7	2		1492-DR7	2		
End Barrier: (Details Page 12-147)	1492-EB3	50		1492-EB3	50		
End Anchors: (Details Page 12-146) DIN Rail — Normal Duty	1492-EA35	50		1492-EA35	50		
DIN Rail — Heavy Duty	1492-EAH35	10		1492-EAH35	10		
Jumpers: (Details Page 12-150) Side Jumper — 10 Pole Insulated	1492-SJ6-10	10		1492-SJ6-10	10		
Other Accessories: Partition Plate	1492-PP3	50		1492-PP3	50		
Test Plug	—	—		1492-TP23	50		
Group Marking Carrier	1492-GM35	10		1492-GM35	10		
Marking Systems: (See Page 12-155)	1492-SM6X12	5		1492-SM6X12	5		

- ① Overall height varies with plug-in component. For 1492-DP4, use 1.8" (45 mm); for 1492-CP4, use 2.2" (55.5 mm); and for 1492-FP4..., use 2.4" (60.0 mm).
- ② Maximum current and voltage rating of component plug is 1 amp @ 600V. Maximum current rating for the base terminal block is listed under Specifications.
- ③ Maximum current and voltage ratings for the fuse plug are 10 amps and 250 volts, respectively. Maximum ratings for the base blocks are listed under Specifications.
- ④ See page 12-170 for Fuse Plug Specifications.

IEC Terminal Blocks

Two Level Plug-In Style Blocks

1492-WD4P ①

1492-WD4PSS ①

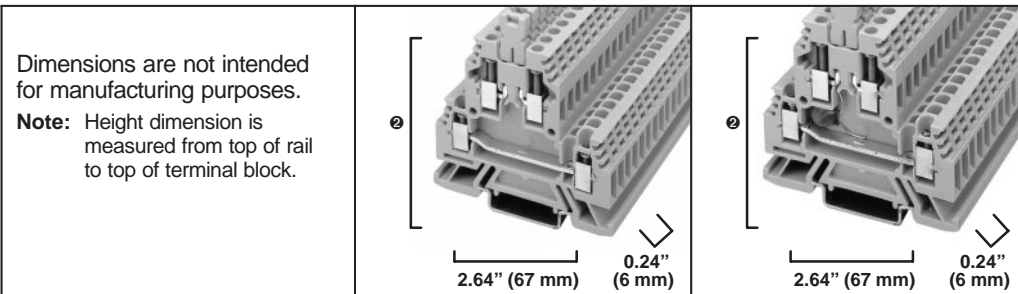

Dimensions are not intended for manufacturing purposes.

Note: Height dimension is measured from top of rail to top of terminal block.

Specifications

Two level terminal block with top level capable of accepting plug-in components and lower level acting as an independent feed-through circuit.

Two level block with top level capable of accepting plug-in components, lower level acting as an independent feed-through circuit, and an MOV between top and bottom levels.

Approvals (See Page 12-6)		CSA	IEC		CSA	IEC
Voltage Rating	300V AC/DC	300V AC/DC	500V AC/DC	300V AC/DC ③	300V AC/DC ③	500V AC/DC ③
Maximum Current	15A	15A	20A	15A ③	15A ③	20A ③
Wire Range (Rated Cross Section)	#22-#12 AWG	#22-#12 AWG	0.5-2.5 mm ²	#18-#12 AWG	#18-#12 AWG	0.75-2.5 mm ²
Wire Strip Length	0.31" (8 mm)			0.31" (8 mm)		
Recommended Tightening Torque	5.0-5.6 lb.-in. (0.6 Nm)			5.0-5.6 lb.-in. (0.6 Nm)		
Density	50 pcs./ft. (166/m)			50 pcs./ft. (166/m)		
Insulation Temperature Range	-40°C to +90°C			-40°C to +90°C		

Terminal Blocks	Catalog No.	Pcs./Pkg.	*	Catalog No.	Pcs./Pkg.	*
Terminal Block:	1492-WD4P ①	50		1492-WD4PSS ①	50	
Inserts: Disconnect Plug	1492-DP4 (shown)	50		1492-DP4 (shown)	50	
Component Plug	1492-CP4 ④	50		1492-CP4 ④	50	
Fuse Plug	1492-FP4 ⑤⑥	50		1492-FP4 ⑤⑥	50	
Fuse Plug w/LED Blown Fuse Indication	1492-FP424 ⑤⑥	50		1492-FP424 ⑤⑥	50	
Fuse Plug w/LED Blown Fuse Indication	1492-FP4250 ⑤⑥	50		1492-FP4250 ⑤⑥	50	

Accessories	Catalog No.	Pcs./Pkg.	*	Catalog No.	Pcs./Pkg.	*
Mounting Rails: (Details Page 12-143) 1 M Symmetrical DIN (Steel)	199-DR1	5		199-DR1	5	
1 M Symmetrical DIN (Aluminum)	1492-DR5	5		1492-DR5	5	
1 M Hi-Rise Sym. DIN (Aluminum)	1492-DR6	2		1492-DR6	2	
1 M Angled Hi-Rise Sym. DIN (Steel)	1492-DR7	2		1492-DR7	2	
End Barrier: (Details Page 12-148)	1492-EBD4P	50		1492-EBD4P	50	
End Anchors: (Details Page 12-146) DIN Rail — Normal Duty	1492-EA35	50		1492-EA35	50	
DIN Rail — Heavy Duty	1492-EAH35	10		1492-EAH35	10	
Jumpers: (Details Page 12-150) Side Jumper — 10 Pole Insulated	1492-SJ6-10	10		1492-SJ6-10	10	
Center Jumper — 10 Pole	1492-CJD6-10	10		1492-CJD6-10	10	
Center Jumper — 3 Pole	1492-CJD6-3	10		1492-CJD6-3	10	
Center Jumper — 2 Pole	1492-CJD6-2	10		1492-CJD6-2	10	
Center Jumper Link	1492-CJL6	10		1492-CJL6	10	
Other Accessories: Partition Plate	1492-PPD4P	50		1492-PPD4P	50	
Test Plug	1492-TP28	10		1492-TP28	10	
Test Plug Adapter	1492-TA40	10		1492-TA40	10	
Group Marking Carrier	1492-GM35	10		1492-GM35	10	
Marking Systems: (See Page 12-155)	1492-SM6X9	5		1492-SM6X9	5	

① Version with test plug screws on upper level available by adding "TP" to end of Catalog No.. Example: 1492-WDG4PSSTP.

② Overall height varies with plug-in component. For 1492-DP4, use 2.5" (63.5 mm); for 1492-CP4, use 2.9" (74 mm); and for 1492-FP4..., use 3.1" (78 mm).

③ See page 12-170 for Electrical Component Data. ④ See footnote ② on page 12-21.

⑤ See footnote ③ on page 12-21. ⑥ See page 12-170 for Fuse Plug Specifications.

1492-WDG4P ①

1492-WDG4PSS ①

Dimensions are not intended for manufacturing purposes. Note: Height dimension is measured from top of rail to top of terminal block.						
Specifications	Three level terminal block with top level capable of accepting plug-in components, second level acting as an independent feed-through circuit, and third level acting as a grounding circuit.		Two level block with top level capable of accepting plug-in components and second level acting as a grounding circuit, with an MOV between top and bottom levels.			
Approvals (See Page 12-6)		CSA	IEC		CSA	IEC
Voltage Rating	300V AC/DC	300V AC/DC	500V AC/DC	300V AC/DC ③	300V AC/DC③	500V AC/DC③
Maximum Current	15A	15A	20A	15A ③	15A ③	20A ③
Wire Range (Rated Cross Section)	#22-#12 AWG	#22-#12 AWG	0.5-2.5 mm ²	#18-#12 AWG	#18-#12 AWG	0.75-2.5 mm ²
Wire Strip Length	0.31" (8 mm)			0.31" (8mm)		
Recommended Tightening Torque	5.0-5.6 lb.-in. (0.6 Nm)			5.0-5.6 lb.-in. (0.6 Nm)		
Density	50 pcs./ft. (166/m)			50 pcs./ft. (166/m)		
Insulation Temperature Range	-40°C to +90°C			-40°C to +90°C		
Terminal Blocks	Catalog No.	Pcs./ Pkg.	*	Catalog No.	Pcs./ Pkg.	*
Terminal Block:	1492-WDG4P ①	50		1492-WDG4PSS①	50	
Inserts: Disconnect Plug	1492-DP4 (shown)	50		1492-DP4 (shown)	50	
Component Plug	1492-CP4 ④	50		1492-CP4 ④	50	
Fuse Plug	1492-FP4 ⑤⑥	50		1492-FP4 ⑤⑥	50	
Fuse Plug w/LED Blown Fuse Indication	1492-FP424 ⑤⑥	50		1492-FP424 ⑤⑥	50	
Fuse Plug w/LED Blown Fuse Indication	1492-FP4250⑤⑥	50		1492-FP4250⑤⑥	50	
Accessories	Catalog No.	Pcs./ Pkg.	*	Catalog No.	Pcs./ Pkg.	*
Mounting Rails: (Details Page 12-143) 1 M Symmetrical DIN (Steel)	199-DR1	50		199-DR1	50	
1 M Symmetrical DIN (Aluminum)	1492-DR5	5		1492-DR5	5	
1 M Hi-Rise Sym. DIN (Aluminum)	1492-DR6	2		1492-DR6	2	
1 M Angled Hi-Rise Sym. DIN (Steel)	1492-DR7	2		1492-DR7	2	
End Barrier: (Details Page 12-148)	1492-EBD4P	50		1492-EBD4P	50	
End Anchors: (Details Page 12-146) DIN Rail — Normal Duty	1492-EA35	50		1492-EA35	50	
DIN Rail — Heavy Duty	1492-EAH35	10		1492-EAH35	10	
Jumpers: (Details Page 12-150) Side Jumper — 10 Pole Insulated	1492-SJ6-10	10		1492-SJ6-10	10	
Center Jumper — 10 Pole	1492-CJD6-10	10		—	—	
Center Jumper — 3 Pole	1492-CJD6-3	10		—	—	
Center Jumper — 2 Pole	1492-CJD6-2	10		—	—	
Center Jumper Link	1492-CJL6	10		—	—	
Other Accessories: Partition Plate	1492-PPD4P	50		1492-PPD4P	50	
Test Plug	1492-TP28	10		—	—	
Test Plug Adapter	1492-TA40	10		—	—	
Group Marking Carrier	1492-GM35	10		1492-GM35	10	
Marking Systems: (See Page 12-155)	1492-SM6X9	5		1492-SM6X9	5	

① Version with test plug screws on upper level available by adding "TP" to end of Catalog No.. Example: 1492-WDG4PSSTP.
 ② Overall height varies with plug-in component. For 1492-DP4, use 2.5" (63.5 mm); for 1492-CP4, use 2.9" (74 mm); and for 1492-FP4.., use 3.1" (78 mm).
 ③ See page 12-170 for Electrical Component Data. ④ See footnote ② on page 12-21.
 ⑤ See footnote ② on page 12-21. ⑥ See page 12-170 for Fuse Plug Specifications.

Bulletin 1492
IEC Terminal Blocks
Fuse Blocks

1492-WFB4

1492-WFB424

1492-WFB4250

Dimensions are not intended for manufacturing purposes.

Note: Height dimension is measured from top of rail to top of terminal block.

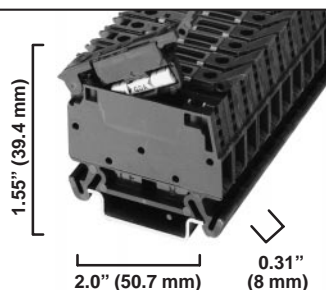
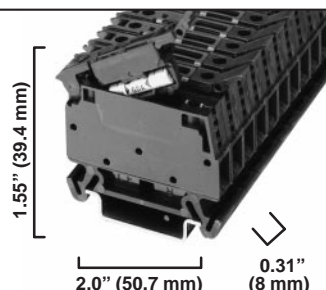
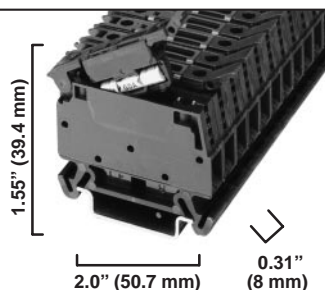

Specifications

Approvals (See Page 12-6)	Single circuit fuse block.			Single circuit fuse block with LED blown fuse indicator.			Single circuit fuse block with neon blown fuse indicator.		
		CSA	IEC		CSA	IEC		CSA	IEC
Voltage Rating	300V AC/DC	300V AC/DC	500V AC/DC	300V AC/DC	300V AC/DC	500V AC/DC	300V AC/DC	300V AC/DC	500V AC/DC
Maximum Current	15A	15A	15A	15A	15A	15A	15A	15A	15A
Wire Range (Rated Cross Section)	#22-#12 AWG	#22-#12 AWG	0.5-4 mm ²	#22-#12 AWG	#22-#12 AWG	0.5-4 mm ²	#22-#12 AWG	#22-#12 AWG	0.5-4 mm ²
Indicator Type	Non-Indicating			LED			Neon		
Leakage Current	—			2mA @ 24V			1mA @ 264V		
Working Voltage	Per Fuse Rating			10-57V AC/DC			85-264V AC		
Fuse Size (Not Supplied)	5 x 20 mm			5 x 20 mm			5 x 20 mm		
Wire Strip Length	0.31" (8 mm)			0.31" (8 mm)			0.31" (8 mm)		
Recommended Tightening Torque	5.0-5.6 lb.-in. (0.6 Nm)			5.0-5.6 lb.-in. (0.6 Nm)			5.0-5.6 lb.-in. (0.6 Nm)		
Density	38 pcs./ft. (125/m)			38 pcs./ft. (125/m)			38 pcs./ft. (125/m)		
Insulation Temperature Range	-40°C to +90°C			-40°C to +90°C			-40°C to +90°C		

Terminal Blocks

	Catalog No.	Pcs./Pkg.	*	Catalog No.	Pcs./Pkg.	*	Catalog No.	Pcs./Pkg.	*
Terminal Block:	1492-WFB4	50		1492-WFB424	50		1492-WFB4250	50	

Accessories

	Catalog No.	Pcs./Pkg.	*	Catalog No.	Pcs./Pkg.	*	Catalog No.	Pcs./Pkg.	*
Mounting Rails: (Details Page 12-143) 1 M Symmetrical DIN (Steel)	199-DR1	5		199-DR1	5		199-DR1	5	
1 M Symmetrical DIN (Aluminum)	1492-DR5	5		1492-DR5	5		1492-DR5	5	
1 M Hi-Rise Sym. DIN (Aluminum)	1492-DR6	2		1492-DR6	2		1492-DR6	2	
1 M Angled Hi-Rise Sym. DIN (Steel)	1492-DR7	2		1492-DR7	2		1492-DR7	2	
End Barrier:	Not Required	—		Not Required	—		Not Required	—	
End Anchors: (Details Page 12-146) DIN Rail — Normal Duty	1492-EA35	50		1492-EA35	50		1492-EA35	50	
DIN Rail — Heavy Duty	1492-EAH35	10		1492-EAH35	10		1492-EAH35	10	
Jumpers: (Details Page 12-150) Side Jumper — 10 Pole Insulated	1492-SJFB8-10	10		1492-SJFB8-10	10		1492-SJFB8-10	10	
Side Jumper — 10 Pole Uninsulated	—	—		—	—		—	—	
Other Accessories: Partition Plate	1492-PPSL3	50		1492-PPSL3	50		1492-PPSL3	50	
Group Marking Carrier	1492-GM35	10		1492-GM35	10		1492-GM35	10	
Marking Systems: (See Page 12-155) For Base Block	1492-SM8X12	5		1492-SM8X12	5		1492-SM8X12	5	
For Handle	1492-SM6X9	5		1492-SM6X9	5		1492-SM6X9	5	

IEC standards for 5 x 20mm fuses do not include ratings above 6.3A.

1492-H4

1492-H5

1492-H6

<p>Dimensions are not intended for manufacturing purposes.</p> <p>Note: Height dimension is measured from top of rail to top of terminal block.</p>									
	<p>Single circuit fusible terminal block with neon blown fuse indicator.</p>			<p>Single circuit fusible terminal block with LED blown fuse indicator.</p>			<p>Single circuit fusible terminal block without a blown fuse indicator.</p>		
Specifications									
Approvals (See Page 12-6)		CSA	IEC		CSA	IEC		CSA	IEC
Voltage Rating	300V AC/DC	300V AC/DC	500V AC/DC	300V AC/DC	300V AC/DC	500V AC/DC	300V AC/DC	300V AC/DC	500V AC/DC
Maximum Current	12A	12A	12A	12A	12A	12A	12A	12A	12A
Wire Range (Rated Cross Section)	#30-#12 AWG	#30-#12 AWG	0.05-4 mm ²	#30-#12 AWG	#30-#12 AWG	0.05-4 mm ²	#30-#12 AWG	#30-#12 AWG	0.05-4 mm ²
Indicator Type	Neon			LED			Non-Indicating		
Leakage Current	2mA @ 300V			2mA @ 24V			—		
Working Voltage	100-300V AC			10-57V AC/DC			Per Fuse Rating		
Fuse Size (Not Supplied)	1/4" x 1-1/4"			1/4" x 1-1/4"			1/4" x 1-1/4"		
Wire Strip Length	0.38" (9.7 mm)			0.38" (9.7 mm)			0.38" (9.7 mm)		
Recommended Tightening Torque	3-7 lb.-in. (0.3-0.8 Nm)			3-7 lb.-in. (0.3-0.8 Nm)			3-7 lb.-in. (0.3-0.8 Nm)		
Density	33 pcs./ft. (109/m)			33 pcs./ft. (109/m)			33 pcs./ft. (109/m)		
Insulation Temperature Range	-40°C to +105°C			-40°C to +105°C			-40°C to +105°C		
Terminal Blocks	Catalog No.	Pcs./Pkg.	*	Catalog No.	Pcs./Pkg.	*	Catalog No.	Pcs./Pkg.	*
Terminal Block:	1492-H4	25		1492-H5	25		1492-H6	25	
Accessories	Catalog No.	Pcs./Pkg.	*	Catalog No.	Pcs./Pkg.	*	Catalog No.	Pcs./Pkg.	*
Mounting Rails: (Details Page 12-143) 1 M Symmetrical DIN (Steel)	199-DR1	10		199-DR1	10		199-DR1	10	
1 M Symmetrical DIN (Aluminum)	1492-DR5	10		1492-DR5	10		1492-DR5	10	
1 M Hi-Rise Sym. DIN (Aluminum)	1492-DR6	2		1492-DR6	2		1492-DR6	2	
1 M Angled Hi-Rise Sym. DIN (Steel)	1492-DR7	2		1492-DR7	2		1492-DR7	2	
End Barrier: (Details Page 12-148)	1492-N37	50		1492-N37	50		1492-N37	50	
End Anchors: (Details Page 12-146) DIN Rail — Normal Duty	1492-EA35	50		1492-EA35	50		1492-EA35	50	
DIN Rail — Heavy Duty	1492-EAH35	10		1492-EAH35	10		1492-EAH35	10	
Jumpers: (Details Page 12-150) Side Jumper — 10 Pole Insulated	—	—		—	—		—	—	
Side Jumper — 10 Pole Uninsulated	1492-N49	10		1492-N49	10		1492-N49	10	
Other Accessories: Partition Plate	—	—		—	—		—	—	
Group Marking Carrier	1492-GM35	10		1492-GM35	10		1492-GM35	10	
Marking Systems: (See Page 12-155)	1492-SM8X12	5		1492-SM8X12	5		1492-SM8X12	5	

Bulletin 1492
IEC Terminal Blocks
Fuse Blocks

1492-W4P

<p>Dimensions are not intended for manufacturing purposes.</p> <p>Note: Height dimension is measured from top of rail to top of terminal block.</p>	
--	--

Specifications	<i>Pluggable terminal block.</i>		
Approvals (See Page 12-6)		CSA	IEC
Voltage Rating	600V AC/DC	600V AC/DC	800V AC/DC
Maximum Current	20A	20A	32A
Wire Range (Rated Cross Section)	#22-#12 AWG	#22-#12 AWG	0.5-2.5 mm ²
Indicator Type	—		
Wire Strip Length	0.35" (9 mm)		
Recommended Tightening Torque	5.0 – 5.6 lb.-in. (0.6 Nm)		
Density	50 pcs./ft. (166/m)		
Insulation Temperature Range	-40°C to +90°C		
Working Voltage	—		
Fuse Size (Not Supplied)	5 x 20 mm		

Terminal Blocks	Catalog No.	Pcs./Pkg.	*
Terminal Block:	1492-W4P	50	
Inserts:			
Disconnect Plug	1492-DP4	50	
Component Plug	1492-CP4 ^②	50	
Fuse Plug	1492-FP4 ^{③④}	50	
Fuse Plug w/LED Blown Fuse Indication	1492-FP424 ^{③④} (shown)	50	
Fuse Plug w/LED Blown Fuse Indication	1492-FP4250 ^{③④}	50	

Accessories	Catalog No.	Pcs./Pkg.	*
Mounting Rails: (Details Page 12-143) 1 M Symmetrical DIN (Steel)	199-DR1	10	
1 M Symmetrical DIN (Aluminum)	1492-DR5	10	
1 M Hi-Rise Sym. DIN (Aluminum)	1492-DR6	2	
1 M Angled Hi-Rise Sym. DIN (Steel)	1492-DR7	2	
End Barrier: (Details Page 12-147)	1492-EB3	50	
End Anchors: (Details Page 12-146) DIN Rail — Normal Duty	1492-EA35	50	
DIN Rail — Heavy Duty	1492-EAH35	10	
Jumpers: (Details Page 12-150) Side Jumper — 10 Pole Insulated	1492-SJ6-10	10	
Side Jumper — 10 Pole Uninsulated	—	—	
Other Accessories: Partition Plate	1492-PP3	50	
Marking Systems: (See Page 12-155)	1492-SM6X12	5	

- ^① Overall height varies with plug-in component. For 1492-DP4, use 1.8" (45 mm); for 1492-CP4, use 2.2" (55.5 mm); and for 1492-FP4., use 2.4" (60.0 mm).
- ^② Maximum current and voltage rating of component plug is 1 amp@ 600V. Maximum current rating for the base terminal block is listed under Specifications.
- ^③ Maximum current and voltage ratings for the fuse plug are 10 amps and 250 volts, respectively. Maximum ratings for the base blocks are listed under Specifications.
- ^④ See page 12-170 for Fuse Plug Specifications.

1492-WD4N

1492-WDG4N

1492-WDG4ND

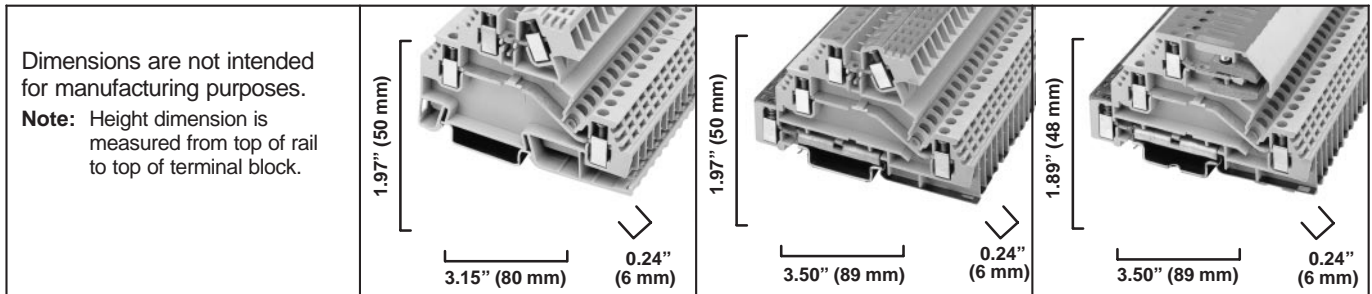

Dimensions are not intended for manufacturing purposes.
Note: Height dimension is measured from top of rail to top of terminal block.



Specifications	1492-WD4N			1492-WDG4N			1492-WDG4ND		
	<i>Installation block with two conductor connections.</i>			<i>Three level installation block with two conductor connections and grounding circuit.</i>			<i>Three level installation block with one phase connection, one neutral disconnect connection, and grounding circuit.</i>		
Approvals (See Page 12-6)			IEC			IEC			IEC
Voltage Rating	300V AC/DC	300V AC/DC	500V AC/DC	300V AC/DC	300V AC/DC	500V AC/DC	300V AC/DC	300V AC/DC	500V AC/DC
Maximum Current	20A	20A	32A	20A	20A	32A	20A	20A	32A
Wire Range (Rated Cross Section)	#24-#12 AWG	#24-#12 AWG	4 mm ²	#24-#12 AWG	#24-#12 AWG	4 mm ²	#24-#12 AWG	#24-#12 AWG	4 mm ²
Wire Strip Length	0.35" (9 mm)			0.35" (9 mm)			0.35" (9 mm)		
Recommended Tightening Torque	5.0-5.6 lb.-in. (0.6 Nm)			5.0-5.6 lb.-in. (0.6 Nm)			5.0-5.6 lb.-in. (0.6 Nm)		
Density	50 pcs./ft. (166/m)			50 pcs./ft. (166/m)			50 pcs./ft. (166/m)		
Insulation Temperature Range	-40°C to +90°C			-40°C to +90°C			-40°C to +90°C		
Terminal Blocks	Catalog No.	Pcs./Pkg.	*	Catalog No.	Pcs./Pkg.	*	Catalog No.	Pcs./Pkg.	*
Terminal Block:	1492-WD4N	20		1492-WDG4N	20		1492-WDG4ND	20	
Accessories	Catalog No.	Pcs./Pkg.	*	Catalog No.	Pcs./Pkg.	*	Catalog No.	Pcs./Pkg.	*
Mounting Rails: (Details Page 12-143) 1 M Symmetrical DIN (Steel)	199-DR1	10		199-DR1	10		199-DR1	10	
1 M Symmetrical DIN (Aluminum)	1492-DR5	10		1492-DR5	10		1492-DR5	10	
1 M Hi-Rise Sym. DIN (Aluminum)	1492-DR6	2		1492-DR6	2		1492-DR6	2	
1 M Angled Hi-Rise Sym. DIN (Steel)	1492-DR7	2		1492-DR7	2		1492-DR7	2	
End Barrier: (Details Page 12-147)	1492-EBD4N	50		1492-EBD4N	50		1492-EBD4N	50	
End Anchors: (Details Page 12-146) DIN Rail — Normal Duty	1492-EA35	50		1492-EA35	50		1492-EA35	50	
DIN Rail — Heavy Duty	1492-EAH35	10		1492-EAH35	10		1492-EAH35	10	
Jumpers: (Details Page 12-150) Side Jumper — 10 Pole Insulated	1492-SJ6-10	10		1492-SJ6-10	10		1492-SJ6-10	10	
Center Jumper — 10 Pole	1492-CJN6-10	10		1492-CJN6-10	10		1492-CJN6-10	10	
Center Jumper — 3 Pole	1492-CJN6-3	10		1492-CJN6-3	10		1492-CJN6-3	10	
Center Jumper — 2 Pole	1492-CJN6-2	10		1492-CJN6-2	10		1492-CJN6-2	10	
Other Accessories:									
Neutral Connecting Block (16 mm ²)	—	—		—	—		1492-WNC16	5	
Neutral Connecting Block (35 mm ²)	—	—		—	—		1492-WNC35	5	
Neutral Busbar (1 M)	—	—		—	—		1492-NBB3-1M	1	
Test Plug Adapter	1492-TA285	10		1492-TA285	10		1492-TA285	10	
Group Marking Carrier	1492-GM35	10		1492-GM35	10		1492-GM35	10	
Marking Systems: (See Page 12-155)	1492-SM6X9	5		1492-SM6X9	5		1492-SM6X9	5	

Bulletin 1492
IEC Terminal Blocks
Installation Blocks

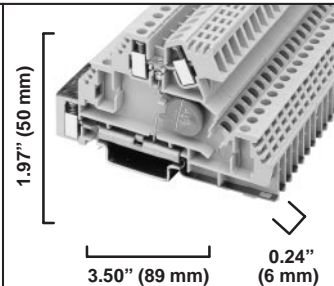
1492-WDG4NSS

<p>Dimensions are not intended for manufacturing purposes.</p> <p>Note: Height dimension is measured from top of rail to top of terminal block.</p>	
--	---

Specifications	<p><i>Installation block with one independent feed-through circuit, grounding circuit, and MOV between the two levels.</i></p>
-----------------------	--

Approvals (See Page 12-6)			IEC
Voltage Rating ^①	300V AC/DC	300V AC/DC	500V AC/DC
Maximum Current ^①	20A	20A	32A
Wire Range (Rated Cross Section)	#18-#12 AWG	#18-#12 AWG	0.75-4 mm ²
Wire Strip Length	0.35" (9 mm)		
Recommended Tightening Torque	5.0-5.6 lb.-in. (0.6 Nm)		
Density	50 pcs./ft (166/m)		
Insulation Temperature Range	-40°C to +90°C		

Terminal Blocks	Catalog No.	Pcs./Pkg.	*
Terminal Block:	1492-WDG4NSS	20	

Accessories	Catalog No.	Pcs./Pkg.	*
Mounting Rails: (Details Page 12-143) 1 M Symmetrical DIN (Steel)	199-DR1	10	
1 M Symmetrical DIN (Aluminum)	1492-DR5	10	
1 M Hi-Rise Sym. DIN (Aluminum)	1492-DR6	2	
1 M Angled Hi-Rise Sym. DIN (Steel)	1492-DR7	2	
End Barrier: (Details Page 12-147)	1492-EBD4N	50	
End Anchors: (Details Page 12-146) DIN Rail — Normal Duty	1492-EA35	50	
DIN Rail — Heavy Duty	1492-EAH35	10	
Jumpers: (Details Page 12-150) Side Jumper — 10 Pole Insulated	1492-SJ6-10	10	
Center Jumper — 10 Pole	—	—	
Center Jumper — 3 Pole	—	—	
Center Jumper — 2 Pole	—	—	
Other Accessories:			
Neutral Connecting Block (16 mm ²)	—	—	
Neutral Connecting Block (35 mm ²)	—	—	
Neutral Busbar (1 M)	—	—	
Test Plug Adapter	—	—	
Group Marking Carrier	1492-GM35	10	
Marking Systems: (See Page 12-155)	1492-SM6X9	5	

^① See page 12-170 for Electrical Component Data.

	1492-WD4C			1492-WD4DF			1492-WD4DR		
Dimensions are not intended for manufacturing purposes. Note: Height dimension is measured from top of rail to top of terminal block.									
Specifications	Two level terminal block with a commoning bar between the upper and lower levels, providing multiple outputs.			Two level terminal block with a diode in forward bias between the upper and lower levels.			Two level terminal block with a diode in reverse bias between the upper and lower levels.		
Approvals (See Page 12-6)		CSA	IEC		CSA	IEC		CSA	IEC
Voltage Rating	300V AC/DC	300V AC/DC	500V AC/DC	300V AC/DC	300V AC/DC	500V AC/DC	300V AC/DC	300V AC/DC	500V AC/DC
Maximum Current	20A	20A	32A	1A (Diode)	1A (Diode)	1A (Diode)	1A (Diode)	1A (Diode)	1A (Diode)
Wire Range (Rated Cross Section)	#22-#12 AWG	#22-#12 AWG	0.5-4 mm ²	#22-#12 AWG	#22-#12 AWG	0.5-4 mm ²	#22-#12 AWG	#22-#12 AWG	0.5-4 mm ²
Resistor Type	—			—			—		
Resistor Range	—			—			—		
Working Voltage	—			Diode 1N4007			Diode 1N4007		
Wire Strip Length	0.39" (10 mm)			0.39" (10 mm)			0.39" (10 mm)		
Recommended Tightening Torque	5.0-5.6 lb.-in. (0.6 Nm)			5.0-5.6 lb.-in. (0.6 Nm)			5.0-5.6 lb.-in. (0.6 Nm)		
Density	50 pcs./ft. (166/m)			50 pcs./ft. (166/m)			50 pcs./ft. (166/m)		
Insulation Temperature Range	-40°C to +90°C			-40°C to +90°C			-40°C to +90°C		
Terminal Blocks	Catalog No.	Pcs./Pkg.	*	Catalog No.	Pcs./Pkg.	*	Catalog No.	Pcs./Pkg.	*
Terminal Block:	1492-WD4C	1		1492-WD4DF	1		1492-WD4DR	1	
Accessories	Catalog No.	Pcs./Pkg.	*	Catalog No.	Pcs./Pkg.	*	Catalog No.	Pcs./Pkg.	*
Mounting Rails: (Details Page 12-143) 1 M Symmetrical DIN (Steel)	199-DR1	10		199-DR1	10		199-DR1	10	
1 M Symmetrical DIN (Aluminum)	1492-DR5	10		1492-DR5	10		1492-DR5	10	
1 M Hi-Rise Sym. DIN (Aluminum)	1492-DR6	2		1492-DR6	2		1492-DR6	2	
1 M Angled Hi-Rise Sym. DIN (Steel)	1492-DR7	2		1492-DR7	2		1492-DR7	2	
End Barrier: (Details Page 12-147)	1492-EBD3	50		1492-EBD3	50		1492-EBD3	50	
End Anchors: (Details Page 12-146) DIN Rail — Normal Duty	1492-EA35	50		1492-EA35	50		1492-EA35	50	
DIN Rail — Heavy Duty	1492-EAH35	10		1492-EAH35	10		1492-EAH35	10	
Jumpers: (Details Page 12-150) Side Jumper — 10 Pole Insulated	1492-SJ6-10	10		1492-SJ6-10	10		1492-SJ6-10	10	
Center Jumper — 10 Pole	1492-CJD6-10	10		1492-CJD6-10	10		1492-CJD6-10	10	
Center Jumper — 3 Pole	1492-CJD6-3	10		1492-CJD6-3	10		1492-CJD6-3	10	
Center Jumper — 2 Pole	1492-CJD6-2	10		1492-CJD6-2	10		1492-CJD6-2	10	
Other Accessories: Partition Plate	1492-PPD3	50		1492-PPD3	50		1492-PPD3	50	
Separation Plate	1492-SPD3	10		1492-SPD3	50		1492-SPD3	50	
Test Plug	1492-TP28	10		1492-TP28	10		1492-TP28	10	
Test Plug Adapter	1492-TA40	10		1492-TA40	10		1492-TA40	10	
Group Marking Carrier	1492-GM35	10		1492-GM35	10		1492-GM35	10	
Marking Systems: (See Page 12-155)	1492-SM6X9	5		1492-SM6X9	5		1492-SM6X9	5	

See Page 12-167 for Component Specifications.

Bulletin 1492
IEC Terminal Blocks
Component Blocks

1492-W4P

<p>Dimensions are not intended for manufacturing purposes.</p> <p>Note: Height dimension is measured from top of rail to top of terminal block.</p>	
--	--

Specifications	<i>Pluggable terminal block.</i>		
Approvals (See Page 12-6)		CSA	IEC
Voltage Rating	600V AC/DC	600V AC/DC	800V AC/DC
Maximum Current	20A	20A	32A
Wire Range (Rated Cross Section)	#22-#12 AWG	#22-#12 AWG	0.5-2.5 mm ²
Wire Strip Length	0.35" (9 mm)		
Recommended Tightening Torque	5.0 – 5.6 lb.-in. (0.6 Nm)		
Density	50 pcs./ft. (166/m)		
Insulation Temperature Range	-40°C to +90°C		

Terminal Blocks	Catalog No.	Pcs./Pkg.	*
Terminal Block:	1492-W4P	50	
Inserts: Disconnect Plug	1492-DP4	50	
Component Plug	1492-CP4 ^② (shown)	50	
Fuse Plug	1492-FP4 ^{③④}	50	
Fuse Plug w/LED Blown Fuse Indication	1492-FP424 ^{③④}	50	
Fuse Plug w/LED Blown Fuse Indication	1492-FP4250 ^{③④}	50	

Accessories	Catalog No.	Pcs./Pkg.	*
Mounting Rails: (Details Page 12-143) 1 M Symmetrical DIN (Steel)	199-DR1	5	
1 M Symmetrical DIN (Aluminum)	1492-DR5	5	
1 M Hi-Rise Sym. DIN (Aluminum)	1492-DR6	2	
1 M Angled Hi-Rise Sym. DIN (Steel)	1492-DR7	2	
End Barrier: (Details Page 12-147)	1492-EB3	50	
End Anchors: (Details Page 12-146) DIN Rail — Normal Duty	1492-EA35	50	
DIN Rail — Heavy Duty	1492-EAH35	10	
Jumpers: (Details Page 12-150) Side Jumper — 10 Pole Insulated	1492-SJ6-10	10	
Other Accessories: Partition Plate	1492-PP3	50	
Group Marking Carrier	1492-GM35	10	
Marking Systems: (See Page 12-155)	1492-SM6X12	5	

- ① Overall height varies with plug-in component. For 1492-DP4, use 1.8" (45 mm); for 1492-CP4, use 2.2" (55.5 mm); and for 1492-FP4..., use 2.4" (60.0 mm).
- ② Maximum current and voltage rating of component plug is 1 amp @ 600V. Maximum current rating for the base terminal block is listed under Specifications.
- ③ Maximum current and voltage ratings for the fuse plug are 10 amps and 250 volts, respectively. Maximum ratings for the base blocks are listed under Specifications.
- ④ See page 12-170 for Fuse Plug Specifications.

1492-WD4RA . . ①

1492-WD4RC001

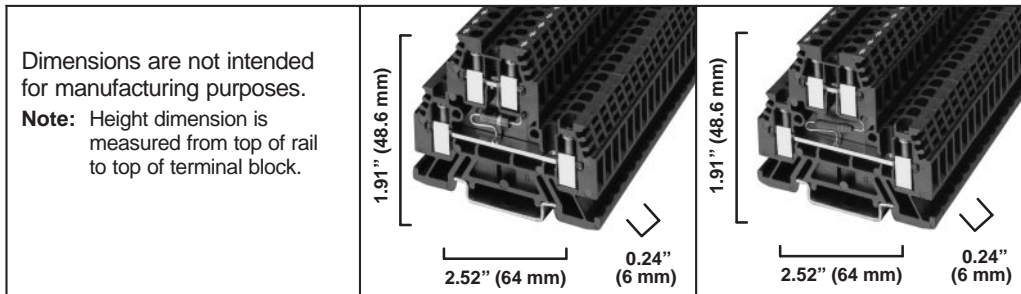

Specifications		Two level terminal block with a resistor secured between the upper and lower levels.				
Approvals (See Page 12-6)		CSA	IEC		CSA	IEC
Maximum Working Voltage ①	300V AC/DC	300V AC/DC	300V AC/DC	250V AC/DC	250V AC/DC	250V AC/DC
Maximum Current (Busses)	20A	20A	32A	20A	20A	32A
Maximum Current (Resistor) ①	0.5VA	0.5VA	0.5VA	0.5VA	0.5VA	0.5VA
Wire Range (Rated Cross Section)	#22-#12 AWG	#22-#12 AWG	4 mm ²	#22-#12 AWG	#22-#12 AWG	4 mm ²
Resistor Type	Carbon Fixed			Precision Wirewound Fixed		
Resistor Range	1.0 Ohm-100 MOhms, 1/2 Watt			249 Ohm, 1/2 Watt		
Wire Strip Length	0.39" (10 mm)			0.39" (10 mm)		
Recommended Tightening Torque	5.0-5.6 lb.-in. (0.6 Nm)			5.0-5.6 lb.-in. (0.6 Nm)		
Density	50 pcs./ft. (166/m)			50 pcs./ft. (166/m)		
Insulation Temperature Range	-40°C to +90°C			-40°C to +90°C		
Terminal Blocks	Catalog No.	Pcs./Pkg.	*	Catalog No.	Pcs./Pkg.	*
TerminalBlock:	1492-WD4RA..②	1		1492-WD4RC001	1	
Accessories	Catalog No.	Pcs./Pkg.	*	Catalog No.	Pcs./Pkg.	*
Mounting Rails: (Details Page 12-143) 1 M Symmetrical DIN (Steel)	199-DR1	10		199-DR1	10	
1 M Symmetrical DIN (Aluminum)	1492-DR5	10		1492-DR5	10	
1 M Hi-Rise Sym. DIN (Aluminum)	1492-DR6	2		1492-DR6	2	
1 M Angled Hi-Rise Sym. DIN (Steel)	1492-DR7	2		1492-DR7	2	
End Barrier: (Details Page 12-147)	1492-EBD3	50		1492-EBD3	50	
End Anchors: (Details Page 12-146) DIN Rail — Normal Duty	1492-EA35	10		1492-EA35	10	
DIN Rail — Heavy Duty	1492-EAH35	10		1492-EAH35	10	
Jumpers: (Details Page 12-150) Side Jumper — 10 Pole Insulated	1492-SJ6-10	10		1492-SJ6-10	10	
Center Jumper — 10 Pole	1492-CJD6-10	10		1492-CJD6-10	10	
Center Jumper — 3 Pole	1492-CJD6-3	10		1492-CJD6-3	10	
Center Jumper — 2 Pole	1492-CJD6-2	10		1492-CJD6-2	10	
Other Accessories: Partition Plate	1492-PPD3	10		1492-PPD3	10	
Separation Plate	1492-SPD3	10		1492-SPD3	10	
Test Plug	1492-TP28	10		1492-TP28	10	
Test Plug Adapter	1492-TA40	50		1492-TA40	50	
Group Marking Carrier	1492-GM35	50		1492-GM35	50	
Marking Systems: (See Page 12-155)	1492-SM6X9	5		1492-SM6X9	5	

① See Page 12-167 for Component Specifications.

② Catalog No. not complete. See page 12-169 to complete Catalog Number.

Bulletin 1492
IEC Terminal Blocks
Surge Suppressor Blocks

1492-WD4SS

Dimensions are not intended for manufacturing purposes.
Note: Height dimension is measured from top of rail to top of terminal block.

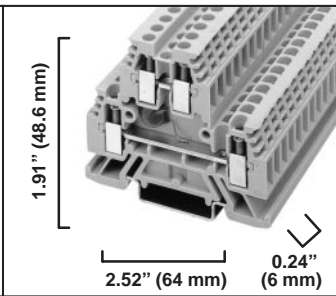

Specifications	<i>Two level terminal block with an MOV between the upper and lower levels.</i>		
Approvals (See Page 12-6)		CSA	IEC
Voltage Rating ^❶	300V AC/DC	300V AC/DC	500V AC/DC
Maximum Current ^❶	20A	20A	32A
Wire Range (Rated Cross Section)	#18-#12 AWG	#18-#12 AWG	0.75-4 mm ²
Leakage Current	—		
Nominal Working Voltage	120V AC/DC		
Wire Strip Length	0.39" (10 mm)		
Recommended Tightening Torque	5.0-5.6 lb.-in. (0.6 Nm)		
Density	50 pcs./ft. (166/m)		
Insulation Temperature Range	-40°C to +90°C		
Terminal Blocks	Catalog No.	Pcs./Pkg.	*
Terminal Block:	1492-WD4SS	1	
Accessories	Catalog No.	Pcs./Pkg.	*
Mounting Rails: (Details Page 12-143) 1 M Symmetrical DIN (Steel)	199-DR1	10	
1 M Symmetrical DIN (Aluminum)	1492-DR5	10	
1 M Hi-Rise Sym. DIN (Aluminum)	1492-DR6	2	
1 M Angled Hi-Rise Sym. DIN (Steel)	1492-DR7	2	
End Barrier: (Details Page 12-147)	1492-EBD3	50	
End Anchors: (Details Page 12-146) DIN Rail — Normal Duty	1492-EA35	50	
DIN Rail — Heavy Duty	1492-EAH35	10	
Jumpers: (Details Page 12-150) Side Jumper — 10 Pole Insulated	1492-SJ6-10	10	
Center Jumper — 10 Pole	1492-CJD6-10	10	
Center Jumper — 3 Pole	1492-CJD6-3	10	
Center Jumper — 2 Pole	1492-CJD6-2	10	
Other Accessories: Partition Plate	1492-PPD3	50	
Separation Plate	1492-SPD3	50	
Test Plug	1492-TP28	10	
Test Plug Adapter	1492-TA40	10	
Group Marking Carrier	1492-GM35	10	
Marking Systems: (See Page 12-155)	1492-SM6X9	5	

^❶ See page 12-170 for Electrical Component Data.

1492-WTC3 . . . ①

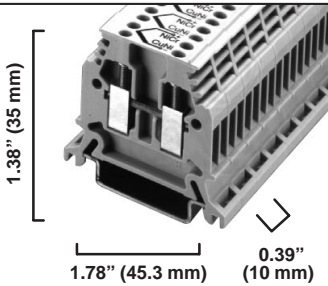
<p>Dimensions are not intended for manufacturing purposes.</p> <p>Note: Height dimension is measured from top of rail to top of terminal block.</p>	
--	---

Specifications	<i>Two pole thermocouple block.</i>		
Approvals (See Page 12-6)	—	—	—
Wire Range (Rated Cross Section)	—	#28-#14 AWG	0.2-2.5 mm ²
Wire Strip Length	0.35" (10 mm)		
Recommended Tightening Torque	5.0-5.6 lb.-in. (0.6 Nm)		
Density	30 pcs./ft. (100/m)		
Insulation Temperature Range	-40°C to +90°C		
Terminal Blocks	Catalog No.	Pcs./Pkg.	*
Material of Conductor: ① 1 Chromel, 1 Constantan	1492-WTC3E	10	
1 Iron, 1 Constantan	1492-WTC3J	10	
1 Chromel, 1 Alumel	1492-WTC3K	10	
1 Copper, 1 Constantan	1492-WTC3T	10	
Accessories	Catalog No.	Pcs./Pkg.	*
Mounting Rails: (Details Page 12-143) 1 M Symmetrical DIN (Steel)	199-DR1	10	
1 M Symmetrical DIN (Aluminum)	1492-DR5	10	
1 M Hi-Rise Sym. DIN (Aluminum)	1492-DR6	2	
1 M Angled Hi-Rise Sym. DIN (Steel)	1492-DR7	2	
End Barrier: (Details Page 12-147)	1492-EB3	50	
End Anchors: (Details Page 12-146) DIN Rail — Normal Duty	1492-EA35	50	
DIN Rail — Heavy Duty	1492-EAH35	10	
Other Accessories: Partition Plate	1492-PP3	50	
Group Marking Carrier	1492-GM35	10	
Marking Systems: (See Page 12-155)	1492-SM5X9	5	

① Thermocouple Blocks are available with four different types of conductor materials. See Material of Conductor under Terminal Blocks.

NOTES

The Allen-Bradley Line of QuickClamp™ Terminal Blocks . . .

Allen-Bradley's new Bulletin 1492-R line of internationally approved screwless IEC style terminal blocks offers a variety of products that can make any application:

- **Fast** – Reduces wiring time by more than 50%.
- **Practical** – Requires only a flat-head screwdriver for easy installation. Maintenance-free, no need to retighten.
- **Reliable** – Secure contact is durable under extreme conditions such as vibration sensitive applications.

Products Available in the QuickClamp™ Line

- **Feed-Through Blocks**, accommodating wire sizes from #26 – #8 AWG
- **Grounding Blocks** to eliminate the need for a separate grounding bus or lug
- **Multi-Circuit Blocks** for doubling circuit wiring density
- **Isolation Blocks** for circuit isolation during testing and troubleshooting
- **Plug-In Style Terminal Blocks** accommodating component plugs, fuse plugs, and disconnect plugs
- **Sensor Blocks** for coordination of three wire sensor groups with or without ground terminations
- **Electrical Component Blocks** which allow for the insertion of fixed components into control circuits. Components include resistors, diodes, and surge suppression circuits
- A wide variety of snap-in markers, marking rods, and labels are available for individual or group circuit identification
- A broad offering of accessories such as screwless end anchors and combination end barriers/partition plates to provide exactly what the application requires

Materials and Design Features

The 1492-R line is specially designed for safety, installation ease, and ruggedness. Features include:

- Tin plated terminals and stainless steel spring clamps for superior resistance to corrosion and vibration
- Optimized spring clamp design to reduce stress relaxation and maintain contact force
- Top wire entry for ease of installation
- Interlocking feature which improves the rigidity of the terminal blocks on rail, allowing installation of several blocks at one time, and prevents open sides from touching
- Insulation stops to ensure electrical connection when using smaller gauge wires
- Markers which are visible after terminal blocks are wired
- Multiple marking options
- Common profiles to minimize stocking of accessories
- Self-extinguishing, polyimide 6.6 housing materials with a flammability rating UL 94-V2

QuickClamp™ Terminal Blocks
Standard Blocks

1492-R3

1492-R3Q

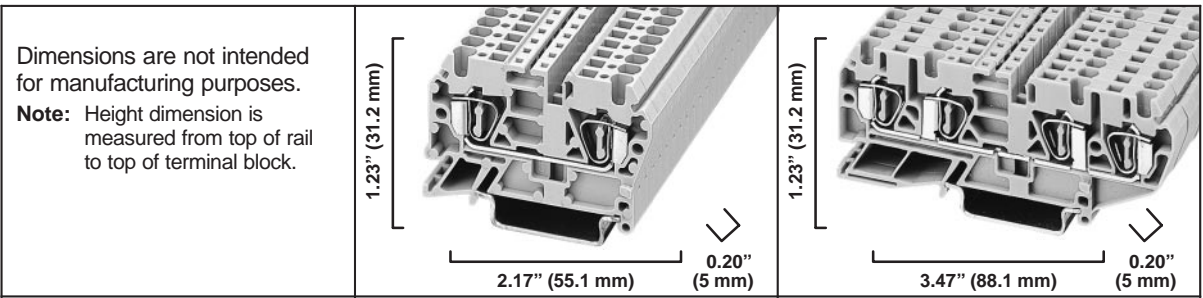

Dimensions are not intended for manufacturing purposes.
Note: Height dimension is measured from top of rail to top of terminal block.

Specifications		Single circuit terminal block.				Single circuit terminal block with 4 wire terminations			
Approvals (See Page 12-6)				IEC	EEx e			IEC	EEx e
Voltage Rating		600V	600V	800V	550V	600V	600V	800V	550V
Maximum Current		20A	20A	24A	24A	20A	20A	24A	24A
Wire Range (Rated Cross Section)		#26-#12 AWG (0.5-2.5 mm ²)				#26-#12 AWG (0.5-2.5 mm ²)			
Wire Strip Length		0.39" (10 mm)				0.39" (10 mm)			
Density		61 pcs/ft (200/m)				61 pcs/ft (200/m)			
Insulation Temperature Range		-40°F to +195°F (-40°C to +90°C)				-40°F to +195°F (-40°C to +90°C)			
Terminal Blocks		Catalog No.	Pcs./Pkg.	*	Catalog No.	Pcs./Pkg.	*		
Color:	Gray	1492-R3	50		1492-R3Q	25			
	Red	1492-R3-RE	50		1492-R3Q-RE	25			
	Blue	1492-R3-B	50		1492-R3Q-B	25			
	Black	1492-R3-BL	50		1492-R3Q-BL	25			
	Green	1492-R3-G	50		1492-R3Q-G	25			
	Yellow	1492-R3-Y	50		1492-R3Q-Y	25			
	Orange	1492-R3-OR	50		1492-R3Q-OR	25			
	White	1492-R3-W	50		1492-R3Q-W	25			
Accessories		Catalog No.	Pcs./Pkg.	*	Catalog No.	Pcs./Pkg.	*		
Mounting Rails: (Details Page 12-143)	1 M Symmetrical DIN (Steel)	199-DR1	10		199-DR1	10			
	1 M Symmetrical DIN (Aluminum)	1492-DR5	10		1492-DR5	10			
	1 M Hi-Rise Sym. DIN (Aluminum)	1492-DR6	2		1492-DR6	2			
	1 M Angled Hi-Rise Sym. DIN (Steel)	1492-DR7	2		1492-DR7	2			
	Terminal Cover/Partition Plate	1492-TC3	50		1492-TC3Q	25			
	Group Marking Carrier/End Retainer	1492-ER35	50		1492-ER35	50			
Jumpers: (Details Page 12-150)	Center Jumper — 10 Pole	1492-CJR5-10	10		1492-CJR5-10	10			
	Center Jumper Link	1492-CJRL5	1010		1492-CJRL5	10			
Other Accessories:	Insulation Stop 0.2mm ² wire (#26 - #24 AWG)	1492-PS3-02	10		1492-PS3-02	10			
	Insulation Stop 0.5mm ² wire (#22-#20 AWG)	1492-PS3-05	10		1492-PS3-05	10			
	Insulation Stop 0.75-1.0mm ² wire (#18 AWG)	1492-PS3-10	10		1492-PS3-10	10			
Marking Systems: (See Page 12-155)	Snap-In Marker 9mm	1492-SM5X9	5		1492-SM5X9	5			
	12 mm	1492-SM5X12	5		1492-SM5X12	5			
	Marking Rod 9mm	1492-MR9	25		1492-MR9	25			
	15 mm	1492-MR15	25		1492-MR15	25			
	Adhesive Label 9mm	1492-AL9	1		1492-AL9	1			
	15 mm	1492-AL15	1		1492-AL15	1			

Covers the center jumper area.

1492-R3T

1492-R4

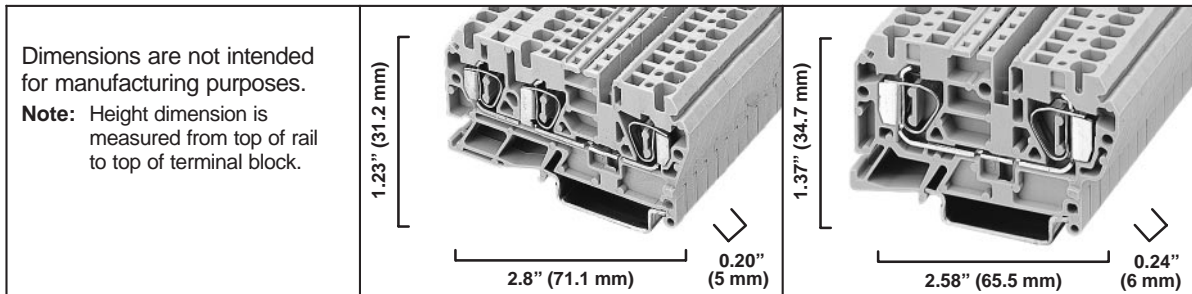

Specifications		<i>Single circuit terminal block with 3 wire terminations</i>				<i>Single circuit terminal block</i>			
Approvals (See Page 12-6)				IEC	EEx e			IEC	EEx e
Voltage Rating		600V	600V	800V	550V	600V	600V	800V	550V
Maximum Current		20A	20A	24A	24A	30A	30A	32A	24A
Wire Range (Rated Cross Section)		#26-#12 AWG (0.5-2.5 mm ²)				#22-#10 AWG (0.5-4.0 mm ²)			
Wire Strip Length		0.39" (10 mm)				0.47" (12 mm)			
Density		61 pcs/ft (200/m)				50 pcs/ft (166/m)			
Insulation Temperature Range		-40°F to +195°F (-40°C to +90°C)				-40°F to +195°F (-40°C to +90°C)			
Terminal Blocks		Catalog No.	Pcs./Pkg.	*	Catalog No.	Pcs./Pkg.	*		
Color:	Gray	1492-R3T	25		1492-R4	50			
	Red	1492-R3T-RE	25		1492-R4-RE	50			
	Blue	1492-R3T-B	25		1492-R4-B	50			
	Black	1492-R3T-BL	25		1492-R4-BL	50			
	Green	1492-R3T-G	25		1492-R4-G	50			
	Yellow	1492-R3T-Y	25		1492-R4-Y	50			
	Orange	1492-R3T-OR	25		1492-R4-OR	50			
	White	1492-R3T-W	25		1492-R4-W	50			
Accessories		Catalog No.	Pcs./Pkg.	*	Catalog No.	Pcs./Pkg.	*		
Mounting Rails: (Details Page 12-143)									
	1 M Symmetrical DIN (Steel)	199-DR1	10		199-DR1	10			
	1 M Symmetrical DIN (Aluminum)	1492-DR5	10		1492-DR5	10			
	1 M Hi-Rise Sym. DIN (Aluminum)	1492-DR6	2		1492-DR6	2			
	1 M Angled Hi-Rise Sym. DIN (Steel)	1492-DR7	2		1492-DR7	2			
Terminal Cover/Partition Plate		1492-TC3T	25		1492-TC4	50			
Group Marking Carrier/End Retainer		1492-ER35	50		1492-ER35	50			
Jumpers: (Details Page 12-150)									
	Center Jumper — 10 Pole	1492-CJR5-10	10		1492-CJR6-10	10			
	Center Jumper Link	1492-CJRL5	10		1492-CJRL6	10			
Other Accessories:									
	Insulation Stop 0.2mm ² wire (#26-#24 AWG)	1492-PS3-02	10		-	-			
	Insulation Stop 0.5mm ² wire (#22-#20 AWG)	1492-PS3-05	10		1492-PS4-05	10			
	Insulation Stop 0.75-1.0mm ² wire (#18 AWG)	1492-PS3-10	10		-	-			
	Insulation Stop 0.75-1.5mm ² wire (#18-#16 AWG)	-	-		1492-PS4-15	10			
Marking Systems: (See Page 12-155)									
	Snap-In Marker 9mm	1492-SM5X9	5		1492-SM5X9	5			
	12 mm	1492-SM5X12	5		1492-SM5X12	5			
	Marking Rod 9mm	1492-MR9	25		1492-MR9	25			
	15 mm	1492-MR15	25		1492-MR15	25			
	Adhesive Label 9mm	1492-AL9	1		1492-AL9	1			
	15 mm	1492-AL15	1		1492-AL15	1			

Covers the center jumper area.

QuickClamp™ Terminal Blocks
Standard Blocks

1492-R4DJ

1492-R4Q

Dimensions are not intended for manufacturing purposes. Note: Height dimension is measured from top of rail to top of terminal block.								
	Single circuit terminal block with dual commoning locations				Single circuit terminal block with 4 wire terminations.			
Approvals (See Page 12-6)			IEC	EEx e			IEC	EEx e
Voltage Rating	600V	600V	800V	550V	600V	600V	800V	550V
Maximum Current	25A	25A	32A	32A	30A	30A	32A	32A
Wire Range (Rated Cross Section)	#22-#10 AWG (0.5-4 mm ²)				#22-#10 AWG (0.5-4 mm ²)			
Wire Strip Length	0.47" (12 mm)				0.47" (12 mm)			
Density	50 pcs/ft (166/m)				50 pcs/ft (166/m)			
Insulation Temperature Range	-40°F to +195°F (-40°C to +90°C)				-40°F to +195°F (-40°C to +90°C)			
Terminal Blocks	Catalog No.	Pcs./Pkg.	*	Catalog No.	Pcs./Pkg.	*		
Color:	Gray	1492-R4DJ	25		1492-R4Q	25		
	Red	1492-R4DJ-RE	25		1492-R4Q-RE	25		
	Blue	1492-R4DJ-B	25		1492-R4Q-B	25		
	Black	1492-R4DJ-BL	25		1492-R4Q-BL	25		
	Green	1492-R4DJ-G	25		1492-R4Q-G	25		
	Yellow	1492-R4DJ-Y	25		1492-R4Q-Y	25		
	Orange	1492-R4DJ-OR	25		1492-R4Q-OR	25		
	White	1492-R4DJ-W	25		1492-R4Q-W	25		
Accessories	Catalog No.	Pcs./Pkg.	*	Catalog No.	Pcs./Pkg.	*		
Mounting Rails: (Details Page 12-143)								
1 M Symmetrical DIN (Steel)	199-DR1	10		199-DR1	10			
1 M Symmetrical DIN (Aluminum)	1492-DR5	10		1492-DR5	10			
1 M Hi-Rise Sym. DIN (Aluminum)	1492-DR6	2		1492-DR6	2			
1 M Angled Hi-Rise Sym. DIN (Steel)	1492-DR7	2		1492-DR7	2			
Terminal Cover/Partition Plate	1492-TC4Q	25		1492-TC4Q	25			
Group Marking Carrier/End Retainer	1492-ER35	50		1492-ER35	50			
Jumpers: (Details Page 12-150)								
Center Jumper — 10 Pole	1492-CJR6-10	10		1492-CJR6-10	10			
Center Jumper Link	1492-CJRL6	10		1492-CJRL6	10			
Other Accessories:								
Insulation Stop 0.5mm ² wire (#22-#20 AWG)	1492-PS4-05	10		1492-PS4-05	10			
Insulation Stop 0.75-1.5mm ² wire (#18-#16 AWG)	1492-PS4-15	10		1492-PS4-15	10			
Marking Systems: (See Page 12-155)								
Snap-In Marker	1492-SM6X9	5		1492-SM6X9	5			
	12 mm	1492-SM6X12	5	1492-SM6X12	5			
Marking Rod	1492-MR9	25		1492-MR9	25			
	15 mm	1492-MR15	25	1492-MR15	25			
Adhesive Label	1492-AL9	1		1492-AL9	1			
	15 mm	1492-AL15	1	1492-AL15	1			

Covers the center jumper area.

1492-R4T

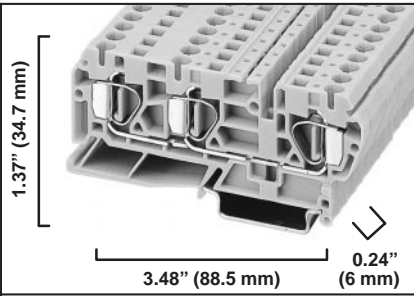
Dimensions are not intended for manufacturing purposes. Note: Height dimension is measured from top of rail to top of terminal block.																																																																					
Specifications	<i>Single circuit terminal block with 3 wire terminations</i>																																																																				
Approvals (See Page 12-6)	<table style="display: inline-table; border: none;"> <tr> <td style="border: none; padding: 0 10px;"></td> <td style="border: none; padding: 0 10px;"></td> <td style="border: none; padding: 0 10px;">IEC</td> <td style="border: none; padding: 0 10px;">EEx e</td> </tr> </table>			IEC	EEx e																																																																
		IEC	EEx e																																																																		
Voltage Rating	600V 600V 800V 550V																																																																				
Maximum Current	30A 30A 32A 32A																																																																				
Wire Range (Rated Cross Section)	#22–#10 AWG (0.5–4 mm ²)																																																																				
Wire Strip Length	0.47" (12 mm)																																																																				
Density	50 pcs/ft (166/m)																																																																				
Insulation Temperature Range	–40°F to +195°F (–40°C to +90°C)																																																																				
Terminal Blocks	<table style="width: 100%; border-collapse: collapse;"> <thead> <tr> <th style="width: 20%;"></th> <th style="width: 15%;">Catalog No.</th> <th style="width: 15%;">Pcs./Pkg.</th> <th style="width: 50%;">*</th> </tr> </thead> <tbody> <tr><td>Color: Gray</td><td>1492-R4T</td><td>25</td><td></td></tr> <tr><td>Red</td><td>1492-R4T-RE</td><td>25</td><td></td></tr> <tr><td>Blue</td><td>1492-R4T-B</td><td>25</td><td></td></tr> <tr><td>Black</td><td>1492-R4T-BL</td><td>25</td><td></td></tr> <tr><td>Green</td><td>1492-R4T-G</td><td>25</td><td></td></tr> <tr><td>Yellow</td><td>1492-R4T-Y</td><td>25</td><td></td></tr> <tr><td>Orange</td><td>1492-R4T-OR</td><td>25</td><td></td></tr> <tr><td>White</td><td>1492-R4T-W</td><td>25</td><td></td></tr> </tbody> </table>		Catalog No.	Pcs./Pkg.	*	Color: Gray	1492-R4T	25		Red	1492-R4T-RE	25		Blue	1492-R4T-B	25		Black	1492-R4T-BL	25		Green	1492-R4T-G	25		Yellow	1492-R4T-Y	25		Orange	1492-R4T-OR	25		White	1492-R4T-W	25																																	
	Catalog No.	Pcs./Pkg.	*																																																																		
Color: Gray	1492-R4T	25																																																																			
Red	1492-R4T-RE	25																																																																			
Blue	1492-R4T-B	25																																																																			
Black	1492-R4T-BL	25																																																																			
Green	1492-R4T-G	25																																																																			
Yellow	1492-R4T-Y	25																																																																			
Orange	1492-R4T-OR	25																																																																			
White	1492-R4T-W	25																																																																			
Accessories	<table style="width: 100%; border-collapse: collapse;"> <thead> <tr> <th style="width: 20%;"></th> <th style="width: 15%;">Catalog No.</th> <th style="width: 15%;">Pcs./Pkg.</th> <th style="width: 50%;">*</th> </tr> </thead> <tbody> <tr><td>Mounting Rails: (Details Page 12-143) 1 M Symmetrical DIN (Steel)</td><td>199-DR1</td><td>10</td><td></td></tr> <tr><td>1 M Symmetrical DIN (Aluminum)</td><td>1492-DR5</td><td>10</td><td></td></tr> <tr><td>1 M Hi-Rise Sym. DIN (Aluminum)</td><td>1492-DR6</td><td>2</td><td></td></tr> <tr><td>1 M Angled Hi-Rise Sym. DIN (Steel)</td><td>1492-DR7</td><td>2</td><td></td></tr> <tr><td>Terminal Cover/Partition Plate</td><td>1492-TC4Q</td><td>25</td><td></td></tr> <tr><td>Group Marking Carrier/End Retainer</td><td>1492-ER35</td><td>50</td><td></td></tr> <tr><td>Jumpers: (Details Page 12-150) Center Jumper — 10 Pole</td><td>1492-CJR6-10</td><td>10</td><td></td></tr> <tr><td>Center Jumper Link</td><td>1492-CJRL6</td><td>10</td><td></td></tr> <tr><td>Other Accessories: Insulation Stop 0.5mm² wire (#22–#20 AWG)</td><td>1492-PS4-05</td><td>10</td><td></td></tr> <tr><td>Insulation Stop 0.75–1.5mm² wire (#18–#16 AWG)</td><td>1492-PS4-15</td><td>10</td><td></td></tr> <tr><td>Marking Systems: (See Page 12-155) Snap-In Marker 9mm</td><td>1492-SM6X9</td><td>5</td><td></td></tr> <tr><td>12 mm </td><td>1492-SM6X12</td><td>5</td><td></td></tr> <tr><td>Marking Rod 9mm</td><td>1492-MR9</td><td>25</td><td></td></tr> <tr><td>15 mm </td><td>1492-MR15</td><td>25</td><td></td></tr> <tr><td>Adhesive Label 9mm</td><td>1492-AL9</td><td>1</td><td></td></tr> <tr><td>15 mm</td><td>1492-AL15</td><td>1</td><td></td></tr> </tbody> </table>		Catalog No.	Pcs./Pkg.	*	Mounting Rails: (Details Page 12-143) 1 M Symmetrical DIN (Steel)	199-DR1	10		1 M Symmetrical DIN (Aluminum)	1492-DR5	10		1 M Hi-Rise Sym. DIN (Aluminum)	1492-DR6	2		1 M Angled Hi-Rise Sym. DIN (Steel)	1492-DR7	2		Terminal Cover/Partition Plate	1492-TC4Q	25		Group Marking Carrier/End Retainer	1492-ER35	50		Jumpers: (Details Page 12-150) Center Jumper — 10 Pole	1492-CJR6-10	10		Center Jumper Link	1492-CJRL6	10		Other Accessories: Insulation Stop 0.5mm ² wire (#22–#20 AWG)	1492-PS4-05	10		Insulation Stop 0.75–1.5mm ² wire (#18–#16 AWG)	1492-PS4-15	10		Marking Systems: (See Page 12-155) Snap-In Marker 9mm	1492-SM6X9	5		12 mm	1492-SM6X12	5		Marking Rod 9mm	1492-MR9	25		15 mm	1492-MR15	25		Adhesive Label 9mm	1492-AL9	1		15 mm	1492-AL15	1	
	Catalog No.	Pcs./Pkg.	*																																																																		
Mounting Rails: (Details Page 12-143) 1 M Symmetrical DIN (Steel)	199-DR1	10																																																																			
1 M Symmetrical DIN (Aluminum)	1492-DR5	10																																																																			
1 M Hi-Rise Sym. DIN (Aluminum)	1492-DR6	2																																																																			
1 M Angled Hi-Rise Sym. DIN (Steel)	1492-DR7	2																																																																			
Terminal Cover/Partition Plate	1492-TC4Q	25																																																																			
Group Marking Carrier/End Retainer	1492-ER35	50																																																																			
Jumpers: (Details Page 12-150) Center Jumper — 10 Pole	1492-CJR6-10	10																																																																			
Center Jumper Link	1492-CJRL6	10																																																																			
Other Accessories: Insulation Stop 0.5mm ² wire (#22–#20 AWG)	1492-PS4-05	10																																																																			
Insulation Stop 0.75–1.5mm ² wire (#18–#16 AWG)	1492-PS4-15	10																																																																			
Marking Systems: (See Page 12-155) Snap-In Marker 9mm	1492-SM6X9	5																																																																			
12 mm	1492-SM6X12	5																																																																			
Marking Rod 9mm	1492-MR9	25																																																																			
15 mm	1492-MR15	25																																																																			
Adhesive Label 9mm	1492-AL9	1																																																																			
15 mm	1492-AL15	1																																																																			

Covers the center jumper area.

QuickClamp™ Terminal Blocks
Standard Blocks

1492-R6

1492-R6T

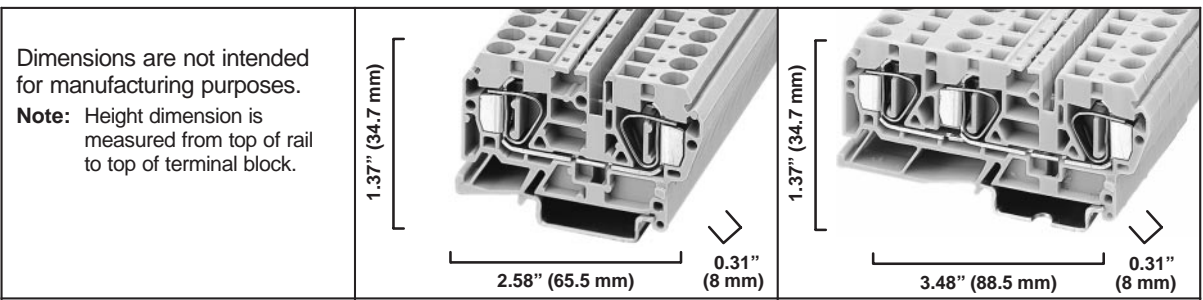

Specifications		Single circuit terminal block				Single circuit terminal block with 3 wire terminations			
Approvals (See Page 12-6)				IEC	EEx e			IEC	EEx e
Voltage Rating		600V	600V	800V	550V	600V	600V	800V	550V
Maximum Current		50A	50A	41A	41A	50A	50A	41A	41A
Wire Range (Rated Cross Section)		#22-#8 AWG (0.5-6 mm ²)				#22-#8 AWG (0.5-6 mm ²)			
Wire Strip Length		0.47" (12 mm)				0.47" (12 mm)			
Density		38 pcs/ft (125/m)				38 pcs/ft (125/m)			
Insulation Temperature Range		-40°F to +195°F (-40°C to +90°C)				-40°F to +195°F (-40°C to +90°C)			
Terminal Blocks		Catalog No.	Pcs./Pkg.	*	Catalog No.	Pcs./Pkg.	*		
Color:	Gray	1492-R6	50		1492-R6T	25			
	Red	1492-R6-RE	50		1492-R6T-RE	25			
	Blue	1492-R6-B	50		1492-R6T-B	25			
	Black	1492-R6-BL	50		1492-R6T-BL	25			
	Green	1492-R6-G	50		1492-R6T-G	25			
	Yellow	1492-R6-Y	50		1492-R6T-Y	25			
	Orange	1492-R6-OR	50		1492-R6T-OR	25			
	White	1492-R6-W	50		1492-R6T-W	25			
Accessories		Catalog No.	Pcs./Pkg.	*	Catalog No.	Pcs./Pkg.	*		
Mounting Rails: (Details Page 12-143)	1 M Symmetrical DIN (Steel)	199-DR1	10		199-DR1	10			
	1 M Symmetrical DIN (Aluminum)	1492-DR5	10		1492-DR5	10			
	1 M Hi-Rise Sym. DIN (Aluminum)	1492-DR6	2		1492-DR6	2			
	1 M Angled Hi-Rise Sym. DIN (Steel)	1492-DR7	2		1492-DR7	2			
	Terminal Cover/Partition Plate	1492-TC4	50		1492-TC4Q	25			
	Group Marking Carrier/End Retainer	1492-ER35	50		1492-ER35	50			
Jumpers: (Details Page 12-150)	Center Jumper — 10 Pole	1492-CJR8-10	10		1492-CJR8-10	10			
	Center Jumper Link	1492-CJRL6	10		1492-CJRL6	10			
Other Accessories:	Insulation Stop 0.5mm ² wire (#22-#20 AWG)	1492-PS6-05	10		1492-PS6-05	10			
	Insulation Stop 0.75-1.5mm ² wire (#18-#16 AWG)	1492-PS6-15	10		1492-PS6-15	10			
Marking Systems: (See Page 12-155)	Snap-In Marker	1492-SM8X9	5		1492-SM8X9	5			
	12 mm	1492-SM8X12	5		1492-SM8X12	5			
	Marking Rod	1492-MR9	25		1492-MR9	25			
	15 mm	1492-MR15	25		1492-MR15	25			
	Adhesive Label	1492-AL9	1		1492-AL9	1			
	15 mm	1492-AL15	1		1492-AL15	1			

Covers the center jumper area.

1492-R4P

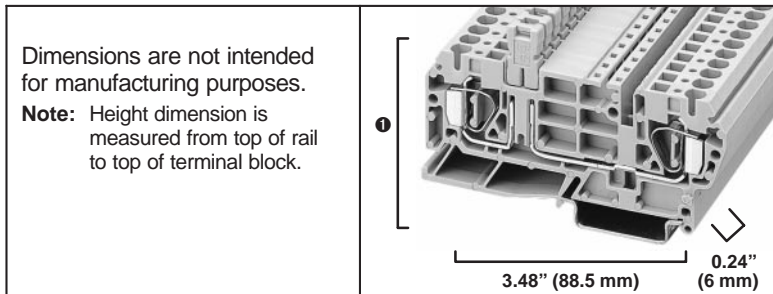



Specifications		<i>Pluggable terminal block.</i>			
Approvals (See Page 12-6)		UL	cUL	IEC	EEx e
Voltage Rating		600V	600V	800V	–
Maximum Current		15A	15A	20A	–
Wire Range (Rated Cross Section)		#22–#10 AWG (0.5–2.5 mm ²)			
Wire Strip Length		0.47" (12 mm)			
Density		50 pcs/ft (166/m)			
Insulation Temperature Range		–40°F to +195°F (–40°C to +90°C)			
Terminal Blocks	Catalog No.	Pcs./ Pkg.	*		
Color: Gray	1492-R4P	25			
Inserts:	Disconnect Plug	1492-DP4 (shown)	50		
	Component Plug	1492-CP4 ^②	50		
	Fuse Plug	1492-FP4 ^③	50		
	Fuse Plug w/LED Blown Fuse Indication	1492-FP424 ^{③④}	50		
	Fuse Plug w/LED Blown Fuse Indication	1492-FP4250 ^{③④}	50		
Accessories	Catalog No.	Pcs./ Pkg.	*		
Mounting Rails: (Details Page 12-143)	199-DR1	10			
1 M Symmetrical DIN (Steel)					
1 M Symmetrical DIN (Aluminum)	1492-DR5	10			
1 M Hi-Rise Sym. DIN (Aluminum)	1492-DR6	2			
1 M Angled Hi-Rise Sym. DIN (Steel)	1492-DR7	2			
Terminal Cover/Partition Plate	1492-TC4Q	25			
Group Marking Carrier/End Retainer	1492-ER35	50			
Jumpers: (Details Page 12-150)					
Center Jumper — 10 Pole	1492-CJR6-10	10			
Center Jumper Link	1492-CJRL6	10			
Other Accessories:					
Insulation Stop 0.5mm ² (#22–#20 AWG) wire	1492-PS4-05	10			
Insulation Stop 0.75–1.5mm ² (#18–#16 AWG) wire	1492-PS4-15	10			
Marking Systems: (See Page 12-155)					
Snap-In Marker 9mm	1492-SM6X9	5			
12 mm ^⑤	1492-SM6X12	5			
Marking Rod 9mm	1492-MR9	25			
15 mm ^⑤	1492-MR15	25			
Adhesive Label 9mm	1492-AL9	1			
15 mm	1492-AL15	1			

- ① Overall height varies with plug-in component. For 1492-DP4, use 1.74" (44.3 mm); for 1492-CP4, use 2.15" (54.7 mm); for 1492-FP4, use 2.33" (59.1 mm).
- ② Maximum current and voltage rating of component plug is 1 amp at 600V. Maximum ratings for the base block is listed under Specifications.
- ③ Maximum current and voltage rating of fuse plug is 10 amps at 250V. Maximum ratings for the base block is listed under Specifications.
- ④ See Page 12-170 for Fuse Plug Specifications.
- ⑤ Covers the center jumper area.

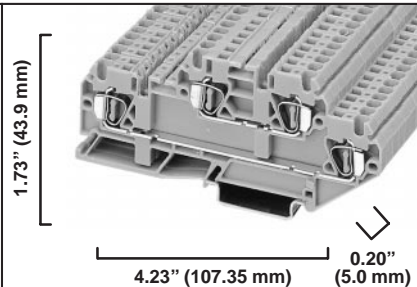
1492-RD3

<p>Dimensions are not intended for manufacturing purposes.</p> <p>Note: Height dimension is measured from top of rail to top of terminal block.</p>	
--	---

Specifications		<i>Two circuit terminal block.</i>			
Approvals (See Page 12-6)		UL	cUL	IEC	EEx e
Voltage Rating		300V	300V	500V	420V
Maximum Current		16A	16A	20A	20A
Wire Range (Rated Cross Section)		#26–#12 AWG (0.5–2.5 mm ²)			
Wire Strip Length		0.39" (10 mm)			
Density		61 pcs/ft (200/m)			
Insulation Temperature Range		–40°F to +195°F (–40°C to +90°C)			
Terminal Blocks	Color:	Catalog No.	Pcs./Pkg.	*	
	Gray	1492-RD3	25		
	Red	1492-RD3-RE	25		
	Blue	1492-RD3-B	25		
	Black	1492-RD3-BL	25		
	Green	1492-RD3-G	25		
	Yellow	1492-RD3-Y	25		
	Orange	1492-RD3-OR	25		
	White	1492-RD3-W	25		
Accessories		Catalog No.	Pcs./Pkg.	*	
Mounting Rails: (Details Page 12-143)	1 M Symmetrical DIN (Steel)	199-DR1	10		
	1 M Symmetrical DIN (Aluminum)	1492-DR5	10		
	1 M Hi-Rise Sym. DIN (Aluminum)	1492-DR6	2		
	1 M Angled Hi-Rise Sym. DIN (Steel)	1492-DR7	2		
	Terminal Cover/Partition Plate	1492-TCD	25		
	Group Marking Carrier/End Retainer	1492-ER35	50		
Jumpers: (Details Page 12-150)	Center Jumper — 10 Pole	1492-CJR5-10	10		
	Center Jumper Link	1492-CJRL5	10		
Other Accessories:	Insulation Stop 0.2mm ² wire (#26–#24 AWG)	1492-PS3-02	10		
	Insulation Stop 0.5mm ² wire (#22–#20 AWG)	1492-PS3-05	10		
	Insulation Stop 0.75–1.0mm ² wire (#18 AWG)	1492-PS3-10	10		
Marking Systems: (See Page 12-155)	Snap-In Marker 9mm	1492-SM5X9	5		
	12 mm 	1492-SM5X12	5		
	Marking Rod 9mm	1492-MR9	25		
	15 mm 	1492-MR15	25		
	Adhesive Label 9mm	1492-AL9	1		
	15 mm	1492-AL15	1		

 Covers the center jumper area.

1492-RKD3

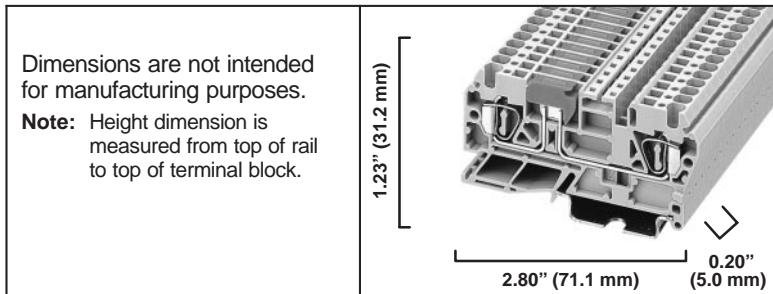

Specifications		<i>Knife style isolating terminal block.</i>		
Approvals (See Page 12-6)	UL	cUL	IEC	EEx e
Voltage Rating	600V	600V	800V	–
Maximum Current	15A	15A	15A	–
Wire Range (Rated Cross Section)	#26-#12 AWG (0.5–2.5mm ²)			
Wire Strip Length	0.39" (10 mm)			
Density	61 pcs./ft. (200/m)			
Insulation Temperature Range	–40°F to +195°F (–40°C to +90°C)			
Terminal Blocks	Catalog No.	Pcs./Pkg.	*	
Color: Gray	1492-RKD3	25		
Accessories	Catalog No.	Pcs./Pkg.	*	
Mounting Rails: (Details Page 12-143) 1 M Symmetrical DIN (Steel)	199-DR1	10		
1 M Symmetrical DIN (Aluminum)	1492-DR5	10		
1 M Hi-Rise Sym. DIN (Aluminum)	1492-DR6	2		
1 M Angled Hi-Rise Sym. DIN (Steel)	1492-DR7	2		
Terminal Cover/Partition Plate	1492-TC3Q	25		
Group Marking Carrier/End Retainer	1492-ER35	50		
Jumpers: (Details Page 12-150) Center Jumper — 10 Pole	1492-CJR5-10	10		
Center Jumper Link	1492-CJRL5	10		
Other Accessories: Insulation Stop for 0.2mm ² wire (#26–#24 AWG)	1492-PS3-02	10		
Insulation Stop for 0.5mm ² wire (#22–#20 AWG)	1492-PS3-05	10		
Insulation Stop for 0.75–1.0mm ² wire (#18 AWG)	1492-PS3-10	10		
Marking Systems: (See Page 12-155) Snap-In Marker 9mm	1492-SM5X9	5		
12 mm ❶	1492-SM5X12	5		
Marking Rod 9mm	1492-MR9	25		
15 mm ❶	1492-MR15	25		
Adhesive Label 9mm	1492-AL9	1		
15 mm	1492-AL15	1		

❶ Covers the center jumper area.

QuickClamp™ Terminal Blocks
Component Blocks

1492-RD3DF

1492-RD3DR

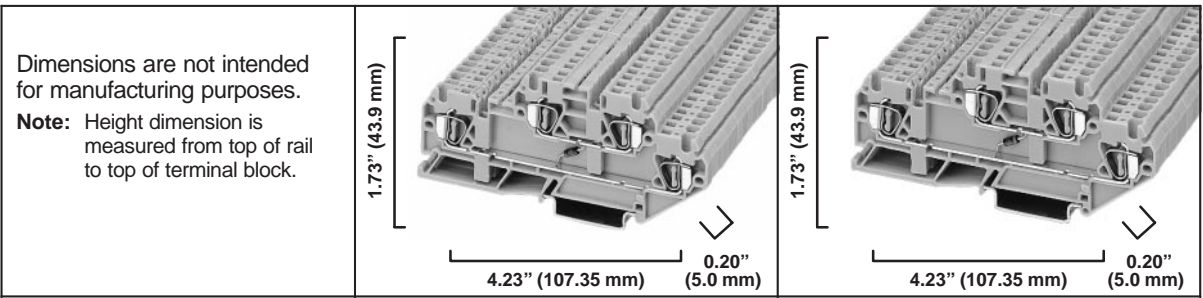

Dimensions are not intended for manufacturing purposes. Note: Height dimension is measured from top of rail to top of terminal block.								
Specifications	<i>Two circuit terminal block with a diode in forward bias between the upper and lower levels.</i>				<i>Two circuit terminal block with a diode in reverse bias between the upper and lower levels.</i>			
Approvals (See Page 12-6)			IEC	EEx e			IEC	EEx e
Voltage Rating	300V	300V	500V	420V	300V	300V	500V	420V
Maximum Current (busses) ❶	16A	16A	20A	20A	16A	16A	20A	20A
Wire Range (Rated Cross Section)	#26-#12 AWG (0.5–2.5mm²)				#26-#12 AWG (0.5–2.5mm²)			
Working Voltage ❶	Diode 1N4007				Diode 1N4007			
Maximum Current (component)	1A (Diode)				1A (Diode)			
Wire Strip Length	0.39" (10 mm)				0.39" (10 mm)			
Density	61 pcs./ft. (200/m)				61 pcs./ft. (200/m)			
Insulation Temperature Range	-40°F to +195°F (-40°C to +90°C)				-40°F to +195°F (-40°C to +90°C)			
Terminal Blocks	Catalog No.	Pcs./Pkg.	*		Catalog No.	Pcs./Pkg.	*	
Color: Gray	1492-RD3DF	1			1492-RD3DR	1		
Accessories	Catalog No.	Pcs./Pkg.	*		Catalog No.	Pcs./Pkg.	*	
Mounting Rails: (Details Page 12-143) 1 M Symmetrical DIN (Steel)	199-DR1	10			199-DR1	10		
1 M Symmetrical DIN (Aluminum)	1492-DR5	10			1492-DR5	10		
1 M Hi-Rise Sym. DIN (Aluminum)	1492-DR6	2			1492-DR6	2		
1 M Angled Hi-Rise Sym. DIN (Steel)	1492-DR7	2			1492-DR7	2		
Terminal Cover/Partition Plate	1492-TCD	25			1492-TCD	25		
Group Marking Carrier/End Retainer	1492-ER35	50			1492-ER35	50		
Jumpers: (Details Page 12-150) Center Jumper — 10 Pole	1492-CJR5-10	10			1492-CJR5-10	10		
Center Jumper Link	1492-CJRL5	10			1492-CJRL5	10		
Other Accessories: Insulation Stop for 0.2mm² wire (#26-#24 AWG)	1492-PS3-02	10			1492-PS3-02	10		
Insulation Stop for 0.5mm² wire (#22-#20 AWG)	1492-PS3-05	10			1492-PS3-05	10		
Insulation Stop for 0.75-1.0mm² wire (#18 AWG)	1492-PS3-10	10			1492-PS3-10	10		
Marking Systems: (See Page 12-155) Snap-In Marker 9mm	1492-SM5X9	5			1492-SM5X9	5		
12 mm ❷	1492-SM5X12	5			1492-SM5X12	5		
Marking Rod 9mm	1492-MR9	25			1492-MR9	25		
15 mm ❷	1492-MR15	25			1492-MR15	25		
Adhesive Label 9mm	1492-AL9	1			1492-AL9	1		
15 mm	1492-AL15	1			1492-AL15	1		

❶ See page 12-170 for Component Specifications.

❷ Covers the center jumper area.

1492-RD3RB...②

1492-RD3SS

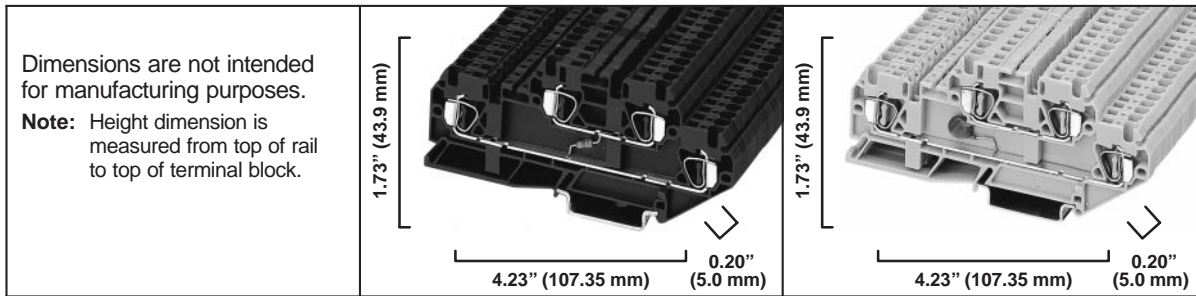

Specifications	<i>Two circuit terminal block with a resistor secured between the upper and lower levels.</i>				<i>Two circuit terminal block with a MOV secured between the upper and lower levels.</i>			
Approvals (See Page 12-6)	UL	UL	IEC	EEx e	UL	UL	IEC	EEx e
Voltage Rating	300V	300V	500V	250V	300V	300V	500V	120V
Maximum Current (busses)①	16A	16A	20A	20A	16A	16A	20A	20A
Wire Range (Rated Cross Section)	#26-#12 AWG (0.5–2.5mm ²)				#26-#12 AWG (0.5–2.5mm ²)			
Resistor Type	Metal Oxide Film Resistor				–			
Resistor Range	10 Ohms to 4.75 Meg ohms				–			
Maximum Current (component)①	0.25 VA				–			
Nominal Working Voltage	–				120V			
Wire Strip Length	0.39" (10 mm)				0.39" (10 mm)			
Density	61 pcs./ft. (200/m)				61 pcs./ft. (200/m)			
Insulation Temperature Range	–40°F to +195°F (–40°C to +90°C)				–40°F to +195°F (–40°C to +90°C)			
Terminal Blocks	Catalog No.	Pcs./Pkg.	*	Catalog No.	Pcs./Pkg.	*		
Color: Gray	–	–		1492-RD3SS	1			
Black	1492-RD3RB②	1		–	–			
Accessories	Catalog No.	Pcs./Pkg.	*	Catalog No.	Pcs./Pkg.	*		
Mounting Rails: (Details Page 12-143) 1 M Symmetrical DIN (Steel)	199-DR1	10		199-DR1	10			
1 M Symmetrical DIN (Aluminum)	1492-DR5	10		1492-DR5	10			
1 M Hi-Rise Sym. DIN (Aluminum)	1492-DR6	2		1492-DR6	2			
1 M Angled Hi-Rise Sym. DIN (Steel)	1492-DR7	2		1492-DR7	2			
Terminal Cover/Partition Plate	1492-TCD	25		1492-TCD	25			
Group Marking Carrier/End Retainer	1492-ER35	50		1492-ER35	50			
Jumpers: (Details Page 12-150) Center Jumper — 10 Pole	1492-CJR5-10	10		1492-CJR5-10	10			
Center Jumper Link	1492-CJRL5	10		1492-CJRL5	10			
Other Accessories: Insulation Stop for 0.2mm ² wire (#26-#24 AWG)	1492-PS3-02	10		1492-PS3-02	10			
Insulation Stop for 0.5mm ² wire (#22-#20 AWG)	1492-PS3-05	10		1492-PS3-05	10			
Insulation Stop for 0.75–1.0mm ² wire (#18 AWG)	1492-PS3-10	10		1492-PS3-10	10			
Marking Systems: (See Page 12-155) Snap-In Marker 9mm	1492-SM5X9	5		1492-SM5X9	5			
12 mm③	1492-SM5X12	5		1492-SM5X12	5			
Marking Rod 9mm	1492-MR9	25		1492-MR9	25			
15mm③	1492-MR15	25		1492-MR15	25			
Adhesive Label 9mm	1492-AL9	1		1492-AL9	1			
15 mm	1492-AL15	1		1492-AL15	1			

- ① See page 12-170 for Component Specifications.
- ② Catalog number is not complete. See page 12-168 to complete catalog number.
- ③ Covers the center jumper area.

QuickClamp™ Terminal Blocks
Sensor Blocks

1492-RTS2

1492-RTSG2

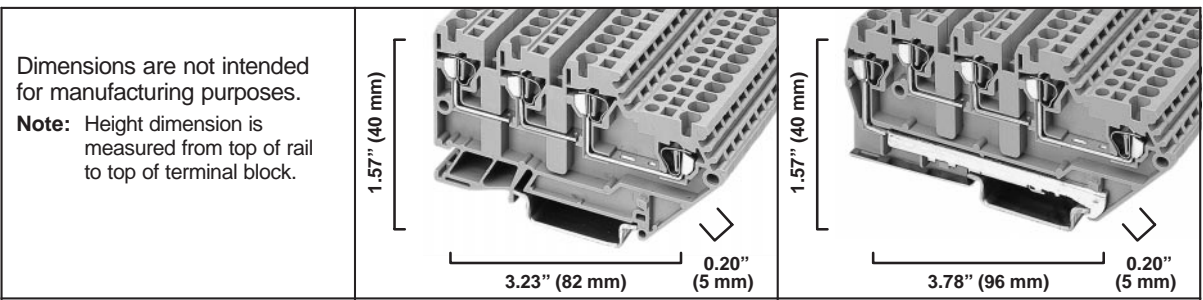

Dimensions are not intended for manufacturing purposes.

Note: Height dimension is measured from top of rail to top of terminal block.

Specifications		<i>Three wire sensor block</i>				<i>Three wire sensor block with ground.</i>			
Approvals (See Page 12-6)				IEC	EEx e			IEC	EEx e
Voltage Rating		50V	50V	60V	30V	50V	50V	60V	30V
Maximum Current		10A	10A	17.5A	17.5A	10A	10A	17.5A	17.5A
Wire Range (Rated Cross Section)		#26-#14 AWG (0.2-1.5mm ²)				#26-#14 AWG (0.2-1.5mm ²)			
Wire Strip Length		0.39" (10 mm)				0.39" (10 mm)			
Density		61 pcs./ft. (200/m)				61 pcs./ft. (200/m)			
Insulation Temperature Range		-40°F to +195°F (-40°C to +90°C)				-40°F to +195°F (-40°C to +90°C)			
Terminal Blocks		Catalog No.	Pcs./Pkg.	*	Catalog No.	Pcs./Pkg.	*		
Color:	Gray	1492-RTS2	25		1492-RTSG2	25			
Accessories		Catalog No.	Pcs./Pkg.	*	Catalog No.	Pcs./Pkg.	*		
Mounting Rails: (Details Page 12-143)									
1 M Symmetrical DIN (Steel)		199-DR1	10		199-DR1	10			
1 M Symmetrical DIN (Aluminum)		1492-DR5	10		1492-DR5	10			
1 M Hi-Rise Sym. DIN (Aluminum)		1492-DR6	2		1492-DR6	2			
1 M Angled Hi-Rise Sym. DIN (Steel)		1492-DR7	2		1492-DR7	2			
Terminal Cover/Partition Plate		1492-TCS	25		1492-TCS	25			
Group Marking Carrier/End Retainer		1492-ER35	50		1492-ER35	50			
Jumpers: (Details Page 12-150)									
Center Jumper — 10 Pole (black insulation)		1492-CJR5-10	10		1492-CJR5-10	10			
Center Jumper — 10 Pole (blue insulation)		1492-CJR5-10-B	10		1492-CJR5-10-B	10			
Center Jumper — 10 Pole (red insulation)		1492-CJR5-10-R	10		1492-CJR5-10-R	10			
Center Jumper Link		1492-CJRL5	10		1492-CJRL5	10			
Other Accessories:									
Insulation Stop for 0.2mm ² wire (#26-#24 AWG)		1492-PS3-02	10		1492-PS3-02	10			
Insulation Stop for 0.5mm ² wire (#22-#20 AWG)		1492-PS3-05	10		1492-PS3-05	10			
Insulation Stop for 0.75-1.0mm ² wire (#18 AWG)		1492-PS3-10	10		1492-PS3-10	10			
Marking Systems: (See Page 12-155)									
Snap-In Marker	9mm	1492-SM5X9	5		1492-SM5X9	5			
	12 mm	-	-		-	-			
Marking Rod	9mm	1492-MR9	25		1492-MR9	25			
	15 mm	-	-		-	-			
Adhesive Label	9mm	1492-AL9	1		1492-AL9	1			
	15 mm	-	-		-	-			

The corners of the terminal blocks may be labelled using a 1492-MR9 marking rod with or without a 1492-AL9 label.

1492-RTSG2LN

1492-RTSG2LP

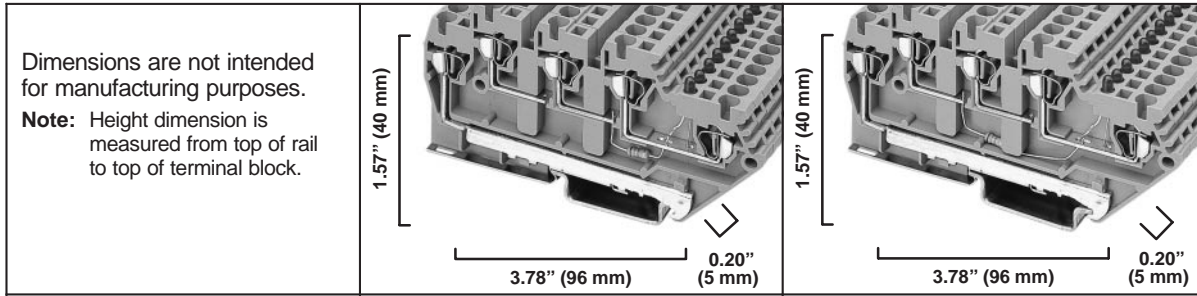

Specifications	<i>Three wire sensor block with LED indicator for NPN devices and ground.</i>				<i>Three wire sensor block with LED indicator for PNP devices and ground.</i>			
Approvals (See Page 12-6)			IEC	EEEx e			IEC	EEEx e
Voltage Rating	50V	50V	60V	30V	50V	50V	60V	30V
Maximum Current	10A	10A	17.5A	17.5A	10A	10A	17.5A	17.5A
Wire Range (Rated Cross Section)	#26-#14 AWG (0.2–1.5mm ²)				#26-#14 AWG (0.2–1.5mm ²)			
Wire Strip Length	0.39" (10 mm)				0.39" (10 mm)			
Density	61 pcs./ft. (200/m)				61 pcs./ft. (200/m)			
Insulation Temperature Range	–40°F to +195°F (–40°C to +90°C)				–40°F to +195°F (–40°C to +90°C)			
Terminal Blocks	Catalog No.	Pcs./Pkg.	*		Catalog No.	Pcs./Pkg.	*	
Color: Gray	1492-RTSG2LN	25			1492-RTSG2LP	25		
Accessories	Catalog No.	Pcs./Pkg.	*		Catalog No.	Pcs./Pkg.	*	
Mounting Rails: (Details Page 12-143) 1 M Symmetrical DIN (Steel)	199-DR1	10			199-DR1	10		
1 M Symmetrical DIN (Aluminum)	1492-DR5	10			1492-DR5	10		
1 M Hi-Rise Sym. DIN (Aluminum)	1492-DR6	2			1492-DR6	2		
1 M Angled Hi-Rise Sym. DIN (Steel)	1492-DR7	2			1492-DR7	2		
Terminal Cover/Partition Plate	1492-TCS	25			1492-TCS	25		
Group Marking Carrier/End Retainer	1492-ER35	50			1492-ER35	50		
Jumpers: (Details Page 12-150) Center Jumper — 10 Pole (black insulation)	1492-CJR5-10	10			1492-CJR5-10	10		
Center Jumper — 10 Pole (blue insulation)	1492-CJR5-10-B	10			1492-CJR5-10-B	10		
Center Jumper — 10 Pole (red insulation)	1492-CJR5-10-R	10			1492-CJR5-10-R	10		
Center Jumper Link	1492-CJRL5	10			1492-CJRL5	10		
Other Accessories: Insulation Stop for 0.2mm ² wire (#26-#24 AWG)	1492-PS3-02	10			1492-PS3-02	10		
Insulation Stop for 0.5mm ² wire (#22-#20 AWG)	1492-PS3-05	10			1492-PS3-05	10		
Insulation Stop for 0.75–1.0mm ² wire (#18 AWG)	1492-PS3-10	10			1492-PS3-10	10		
Marking Systems: (See Page 12-155) Snap-In Marker 9mm	1492-SM5X9	5			1492-SM5X9	5		
12 mm	–	–			–	–		
Marking Rod 9mm	1492-MR9	25			1492-MR9	25		
15 mm	–	–			–	–		
Adhesive Label 9mm	1492-AL9	1			1492-AL9	1		
15 mm	–	–			–	–		

The corners of the terminal blocks may be labelled using a 1492-MR9 marking rod with or without a 1492-AL9 label.

QuickClamp™ Terminal Blocks
Sensor Blocks

1492-RTS2LN

1492-RTS2LP

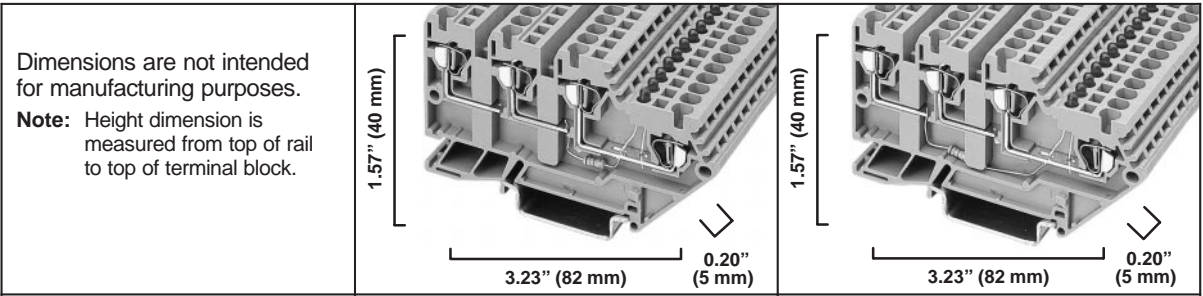

Dimensions are not intended for manufacturing purposes.
Note: Height dimension is measured from top of rail to top of terminal block.

Specifications		<i>Three wire sensor block with LED indicator for NPN devices.</i>				<i>Three wire sensor block with LED indicator for PNP devices.</i>			
Approvals (See Page 12-6)				IEC	EEx e			IEC	EEx e
Voltage Rating		50V	50V	60V	30V	50V	50V	60V	30V
Maximum Current		10A	10A	17.5A	17.5A	10A	10A	17.5A	17.5A
Wire Range (Rated Cross Section)		#26-#14 AWG (0.2-1.5mm ²)				#26-#14 AWG (0.2-1.5mm ²)			
Wire Strip Length		0.39" (10 mm)				0.39" (10 mm)			
Density		61 pcs./ft. (200/m)				61 pcs./ft. (200/m)			
Insulation Temperature Range		-40°F to +195°F (-40°C to +90°C)				-40°F to +195°F (-40°C to +90°C)			
Terminal Blocks	Catalog No.	Pcs./Pkg.	*		Catalog No.	Pcs./Pkg.	*		
Color: Gray	1492-RTS2LN	25			1492-RTS2LP	25			
Accessories	Catalog No.	Pcs./Pkg.	*		Catalog No.	Pcs./Pkg.	*		
Mounting Rails: (Details Page 12-143) 1 M Symmetrical DIN (Steel)	199-DR1	10			199-DR1	10			
1 M Symmetrical DIN (Aluminum)	1492-DR5	10			1492-DR5	10			
1 M Hi-Rise Sym. DIN (Aluminum)	1492-DR6	2			1492-DR6	2			
1 M Angled Hi-Rise Sym. DIN (Steel)	1492-DR7	2			1492-DR7	2			
Terminal Cover/Partition Plate	1492-TCS	25			1492-TCS	25			
Group Marking Carrier/End Retainer	1492-ER35	50			1492-ER35	50			
Jumpers: (Details Page 12-150) Center Jumper — 10 Pole (black insulation)	1492-CJR5-10	10			1492-CJR5-10	10			
Center Jumper — 10 Pole (blue insulation)	1492-CJR5-10-B	10			1492-CJR5-10-B	10			
Center Jumper — 10 Pole (red insulation)	1492-CJR5-10-R	10			1492-CJR5-10-R	10			
Center Jumper Link	1492-CJRL5	10			1492-CJRL5	10			
Other Accessories: Insulation Stop for 0.2mm ² wire (#26-#24 AWG)	1492-PS3-02	10			1492-PS3-02	10			
Insulation Stop for 0.5mm ² wire (#22-#20 AWG)	1492-PS3-05	10			1492-PS3-05	10			
Insulation Stop for 0.75-1.0mm ² wire (#18 AWG)	1492-PS3-10	10			1492-PS3-10	10			
Marking Systems: (See Page 12-155) Snap-In Marker 9mm	1492-SM5X9	5			1492-SM5X9	5			
12 mm	—	—			—	—			
Marking Rod 9mm	1492-MR9	25			1492-MR9	25			
15 mm	—	—			—	—			
Adhesive Label 9mm	1492-AL9	1			1492-AL9	1			
15 mm	—	—			—	—			

The corners of the terminal blocks may be labelled using a 1492-MR9 marking rod with or without a 1492-AL9 label.

1492-RG3

1492-RG4

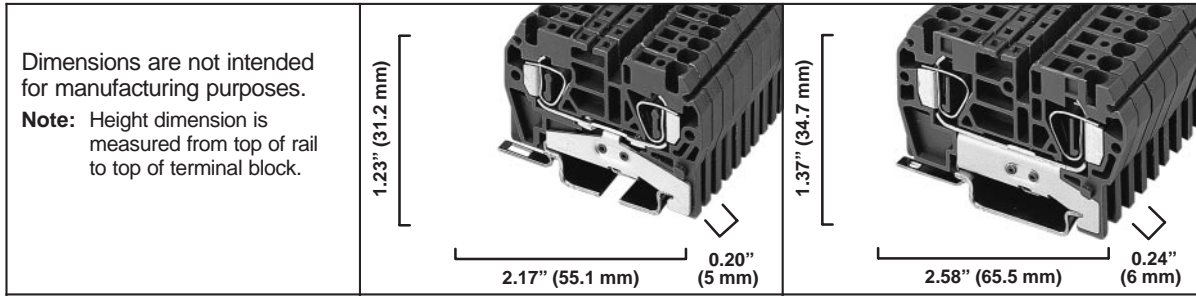

Specifications	Single circuit grounding block.				Single circuit grounding block.			
Approvals (See Page 12-6)	UL	cUL	IEC	EEx e	UL	cUL	IEC	EEx e
Voltage Rating	-	-	-	-	-	-	-	-
Maximum Current	Grounding				Grounding			
Wire Range (Rated Cross Section)	#26-12 AWG (0.5-2.5 mm ²)				#22-10 AWG (0.5-4 mm ²)			
Wire Strip Length	0.39" (10 mm)				0.47" (12 mm)			
Density	61 pcs./ft. (200/m)				50 pcs./ft. (166/m)			
Insulation Temperature Range	-40°F to +195°F (-40°C to +90°C)				-40°F to +195°F (-40°C to +90°C)			
Terminal Blocks	Catalog No.	Pcs./Pkg.	*	*	Catalog No.	Pcs./Pkg.	*	*
Terminal Block	1492-RG3	50			1492-RG4	50		
Accessories	Catalog No.	Pcs./Pkg.	*	*	Catalog No.	Pcs./Pkg.	*	*
Mounting Rails: (Details Page 12-143)								
1 M Symmetrical DIN (Steel)	199-DR1	10			199-DR1	10		
1 M Symmetrical DIN (Aluminum)	1492-DR5	10			1492-DR5	10		
1 M Hi-Rise Sym. DIN (Aluminum)	1492-DR6	2			1492-DR6	2		
1 M Angled Hi-Rise Sym. DIN (Steel)	1492-DR7	2			1492-DR7	2		
Terminal Cover/Partition Plate	1492-TC3-Y	50			1492-TC4-Y	50		
Group Marking Carrier/End Retainer	1492-ER35	50			1492-ER35	50		
Other Assessories:								
Insulation Stop for 0.2mm ² wire (#26-#24 AWG)	1492-PS3-02	10			-	-		
Insulation Stop for 0.5mm ² wire (#22-#20 AWG)	1492-PS3-05	10			1492-PS4-05	-		
Insulation Stop for 1.0mm ² wire (#18 AWG)	1492-PS3-10	10			-	-		
Insulation Stop 0.75-1.5mm ² (#18-#16 AWG)	-	-			1492-PS4-15	10		
Marking Systems: (See Page 12-155)								
Snap-In Marker 9mm	1492-SM5X9	5			1492-SM6X9	5		
12 mm	1492-SM5X12	5			1492-SM6X12	5		
Marking Rod 9mm	1492-MR9	25			1492-MR9	25		
15 mm	1492-MR15	25			1492-MR15	25		
Adhesive Label 9mm	1492-AL9	1			1492-AL9	1		
15 mm	1492-AL15	1			1492-AL15	1		

QuickClamp™ Terminal Blocks

Standard Grounding Blocks

1492-RG6

Dimensions are not intended for manufacturing purposes.

Note: Height dimension is measured from top of rail to top of terminal block.

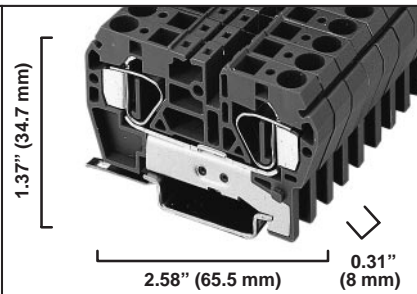

Specifications	Single circuit grounding block.			
Approvals (See Page 12-6)			IEC	EEx e
Voltage Rating	-	-	-	-
Maximum Current	Grounding			
Wire Range (Rated Cross Section)	#22-8 AWG (0.5-6 mm ²)			
Wire Strip Length	0.47" (12 mm)			
Density	38 pcs./ft. (125/m)			
Insulation Temperature Range	-40°F to +195°F (-40°C to +90°C)			
Terminal Blocks	Catalog No.	Pcs./Pkg.	*	
Terminal Block	1492-RG6	50		
Accessories	Catalog No.	Pcs./Pkg.	*	
Mounting Rails: (Details Page 12-143) 1 M Symmetrical DIN (Steel)	199-DR1	10		
1 M Symmetrical DIN (Aluminum)	1492-DR5	10		
1 M Hi-Rise Sym. DIN (Aluminum)	1492-DR6	2		
1 M Angled Hi-Rise Sym. DIN (Steel)	1492-DR7	2		
Terminal Cover/Partition Plate	1492-TC4-Y	50		
Group Marking Carrier/End Retainer	1492-ER35	50		
Other Accessories:				
Insulation Stop for 0.5mm ² wire (#22-#20 AWG)	1492-PS6-05	10		
Insulation Stop for 1.5mm ² wire (#18-#16 AWG)	1492-PS6-15	10		
Marking Systems: (See Page 12-155)				
Snap-In Marker 9mm	1492-SM8X9	5		
12 mm	1492-SM8X12	5		
Marking Rod 9mm	1492-MR9	25		
15 mm	1492-MR15	25		
Adhesive Label 9mm	1492-AL9	1		
15 mm	1492-AL15	1		

Product Features

Allen-Bradley has developed a product line of Finger-Safe terminal blocks that falls in-between the open style NEMA/EEMAC terminal blocks and full function IEC style terminal blocks. Features of our Finger-Safe product line include:

- Compact size to accommodate up to 100 terminations per foot (328 per meter) using the 1492-HM2 design
- Recessed terminals for “Finger-Safe” protection
- All products are UL Component Recognized and CSA Certified, some are IEC Certified
- Factory shipped with backed out screws for ease of wiring
- All products offer multi-rail mounting feet
- 11 colors are available for easy circuit identification (H1, H2, HM1, HM2, and HM3)

Fuse Blocks and Isolation Switches

In addition to our standard multi-rail terminal blocks, Allen-Bradley offers a wide range of fusible terminal blocks and isolation switches. Fuse blocks are available in 3 styles for greater application requirements: 1/4" x 1-1/4" fuse size, 13/32" x 1-1/2" fuse size, and the 1492-UF3 which uses a 'GMT' type alarm fuse. Isolation switches are also available in 2 separate sizes for matching circuitry.

Special Component Terminal Blocks

Allen-Bradley offers a varied line of special component blocks for your unique control designs and applications. Product offerings include:

Tie-Point Block

Tie point block incorporates a shunt bar between the upper and lower current bars to provide a common point among all 4 terminals.

1492-HM2C

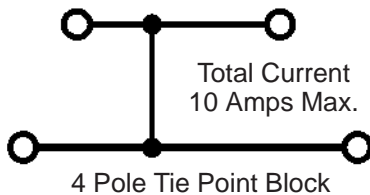

Diode Block

Diode block utilizes a 1N4007 diode between the upper and lower levels for insertion into a control circuit. This block is useful in low voltage DC control circuits for directioning and suppression.

1492-HM2D

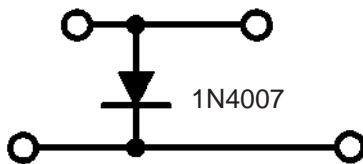

Resistor Block

Resistor blocks permit the introduction of a 1 Ohm to 100M Ohm resistor into a control circuit.

1492-HM2R

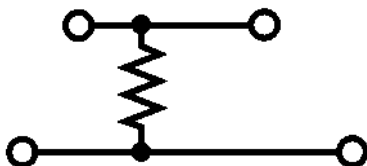

Finger-Safe Terminal Blocks

Voltage Indicating Blocks

Voltage indicating blocks offer a visual indication when a voltage is applied to a control circuit for trouble-shooting or continuity checks.

1492-HM2V24

1492-HM2V250

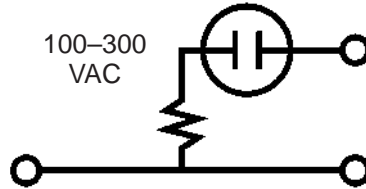
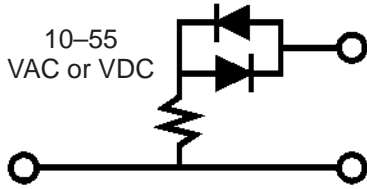

Surge Suppression Block

Surge suppression blocks provide a convenient means of incorporating transient suppression for relays, contactors and solenoids into a control system.

1492-HM2K024

1492-HM2K120

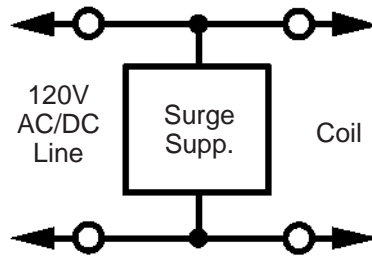
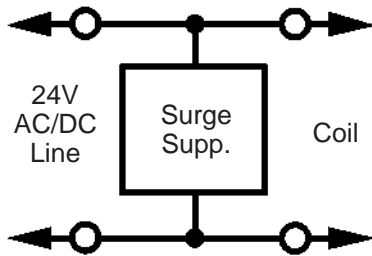

1492-HM2K240

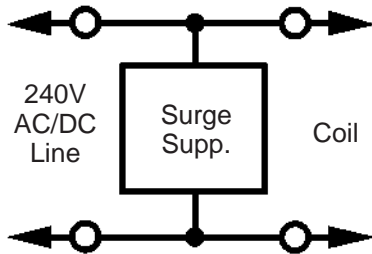

1492-H1

1492-H2

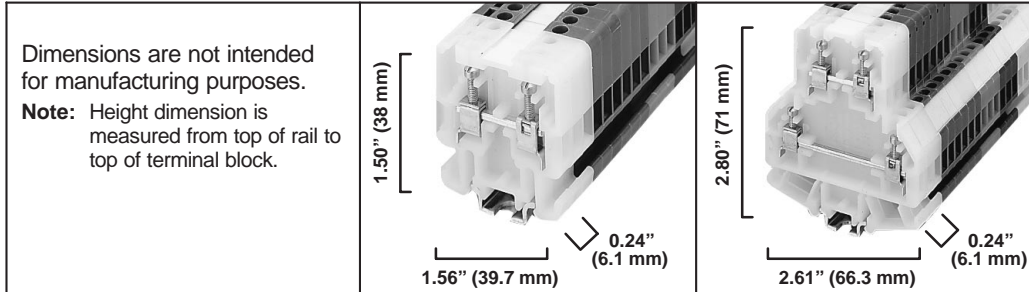

Specifications	<i>Finger-Safe terminal block, single circuit, screw with pressure plate.</i>			<i>Finger-Safe terminal block, two circuit, screw with pressure plate.</i>		
Approvals (See Page 12-6)	UL/CSA			UL/CSA		
Voltage Rating	600V AC/DC			600V AC/DC		
Maximum Current	30A			24A		
Wire Range (Rated Cross Section)	#30-#12 AWG (0.05-4 mm ²)			#30-#12 AWG (0.05-4 mm ²)		
Wire Strip Length	0.38" (9.7 mm)			0.38" (9.7 mm)		
Recommended Tightening Torque	3-7 lb.-in. (0.3-0.8 Nm)			3-7 lb.-in. (0.3-0.8 Nm)		
Density	50 pcs./ft. (164/m)			50 pcs./ft. (164/m)		
Insulation Temperature Range	-40°C to +105°C			-40°C to +105°C		
Terminal Blocks	Catalog No.	Pcs./Pkg.	*	Catalog No.	Pcs./Pkg.	*
Colour: White	1492-H1	80		1492-H2	50	
Two 3' Rails White	1492-H1296 (148/Rail)	1		1492-H2148 (148/Rail)	1	
Gold	1492-H1GL	80		1492-H2GL	50	
Red	1492-H1RE	80		1492-H2RE	50	
Blue	1492-H1B	80		1492-H2B	50	
Black	1492-H1BL	80		1492-H2BL	50	
Green	1492-H1G	80		1492-H2G	50	
Yellow	1492-H1Y	80		1492-H2Y	50	
Brown	1492-H1BR	80		1492-H2BR	50	
Violet	1492-H1VT	80		1492-H2VT	50	
Gray	1492-H1GY	80		1492-H2GY	50	
Orange	1492-H1OR	80		1492-H2OR	50	
Accessories	Catalog No.	Pcs./Pkg.	*	Catalog No.	Pcs./Pkg.	*
Mounting Rails: (Details Page 12-144) 3' Scored A-B Rail	1492-N1	20		1492-N1	20	
3' Rigid A-B Rail	1492-N22	20		1492-N22	20	
3' High Rise A-B Rail	1492-N44	2		1492-N44	2	
Standoff Brackets (use every 12")	1492-N25	2		1492-N25	2	
1 Meter Symmetrical DIN	—	—	—	—	—	—
1 Meter Symmetrical DIN (alumin.)	—	—	—	—	—	—
1 Meter Hi-Rise Symmetrical DIN	—	—	—	—	—	—
1 Meter Angled Hi-Rise Sym. DIN	—	—	—	—	—	—
End Barrier: (Details Page 12-148)	1492-N36	50		1492-N40	50	
End Anchors: (Details Page 12-146) A-B Rail — Heavy Duty	1492-N23	10		1492-N23	10	
A-B Rail — Normal Duty	1492-N47	50		—	—	—
A-B Rail—Retaining Clip—Light Duty	1492-N2	50		—	—	—
DIN Rail — Normal Duty	—	—	—	—	—	—
DIN Rail — Heavy Duty	—	—	—	—	—	—
Jumpers: (Details Page 12-150) 2 Pole Uninsulated	1492-N42	50		1492-N42	50	
10 Pole Insulated	1492-SJ6-10	10		1492-SJ6-10	10	
50 Pole Uninsulated	1492-N39	10		1492-N39	10	
Marking Systems: (See Page 12-154)	1492-N41	50		1492-N41	50	

Bulletin 1492
Finger-Safe Terminal Blocks
High Density

1492-HM1

1492-HM2

1492-HM3

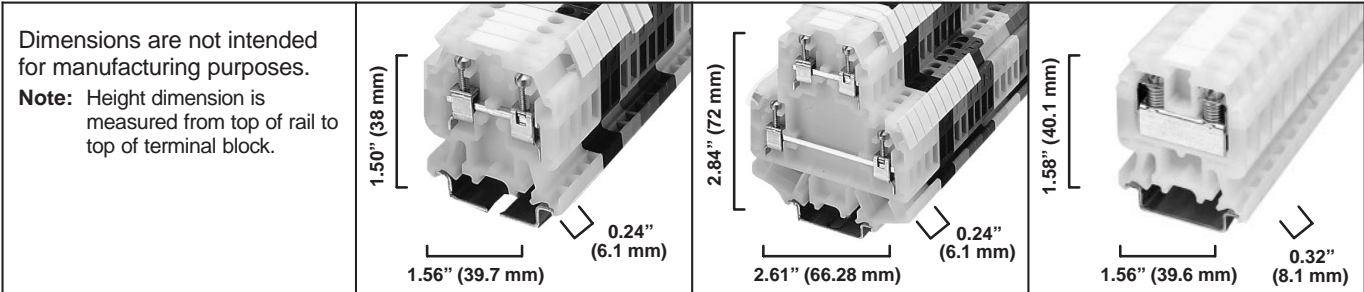

Dimensions are not intended for manufacturing purposes. Note: Height dimension is measured from top of rail to top of terminal block.			
Specifications	<i>Finger-Safe terminal block, single circuit, multi-rail mount.</i>	<i>Finger-Safe terminal block, two circuit, multi-rail mount.</i>	<i>Finger-Safe terminal block, single circuit, multi-rail mount.</i>
Approvals (See Page 12-6)			
Voltage Rating	600V AC/DC	600V AC/DC	600V AC/DC
Maximum Current	30A	24A [IEC: 30A]	55A [IEC: 57A]
Wire Range (Rated Cross Section)	#30-#12 AWG (0.05-4 mm ²)	#30-#12 AWG (0.05-4 mm ²)	#22-#8 AWG (0.5-10 mm ²)
Wire Strip Length	0.38" (9.7 mm)	0.38" (9.7 mm)	0.38" (9.7 mm)
Recommended Tightening Torque	3-7 lb.-in. (0.3-0.8 Nm)	3-7 lb.-in. (0.3-0.8 Nm)	8-16 lb.-in. (0.9-1.8 Nm)
Density	50 pcs./ft. (164/m)	50 pcs./ft. (164/m)	37 pcs./ft. (123/m)
Insulation Temperature Range	-40°C to +105°C	-40°C to +105°C	-40°C to +105°C

Terminal Blocks		Catalog No.	Pcs./ Pkg.	*	Catalog No.	Pcs./ Pkg.	*	Catalog No.	Pcs./ Pkg.	*
Colour:	White	1492-HM1	80		1492-HM2	50		1492-HM3	50	
	Gold	1492-HM1GL	80		1492-HM2GL	50		—	—	—
	Red	1492-HM1RE	80		1492-HM2RE	50		1492-HM3RE	50	
	Blue	1492-HM1B	80		1492-HM2B	50		1492-HM3B	50	
	Black	1492-HM1BL	80		1492-HM2BL	50		1492-HM3BL	50	
	Green	1492-HM1G	80		1492-HM2G	50		1492-HM3G	50	
	Yellow	1492-HM1Y	80		1492-HM2Y	50		1492-HM3Y	50	
	Brown	1492-HM1BR	80		1492-HM2BR	50		1492-HM3BR	50	
	Violet	1492-HM1VT	80		1492-HM2VT	50		1492-HM3VT	50	
	Gray	1492-HM1GY	80		1492-HM2GY	50		1492-HM3GY	50	
	Orange	1492-HM1OR	80		1492-HM2OR	50		1492-HM3OR	50	

Accessories		Catalog No.	Pcs./ Pkg.	*	Catalog No.	Pcs./ Pkg.	*	Catalog No.	Pcs./ Pkg.	*
Mounting Rails: (Details Page 12-144)										
	3' Scored A-B Rail	1492-N1	20		1492-N1	20		1492-N1	20	
	3' Rigid A-B Rail	1492-N22	20		1492-N22	20		1492-N22	20	
	3' High Rise A-B Rail	1492-N44	2		1492-N44	2		1492-N44	2	
	Standoff Brackets (use every 12")	1492-N25	2		1492-N25	2		1492-N25	2	
	1 Meter Symmetrical DIN	199-DR1	10		199-DR1	10		199-DR1	5	
	1 Meter Symmetrical DIN (alumin.)	1492-DR5	10		1492-DR5	10		1492-DR5	5	
	1 Meter Hi-Rise Symmetrical DIN	1492-DR6	2		1492-DR6	2		1492-DR6	2	
	1 Meter Angled Hi-Rise Sym. DIN	1492-DR7	2		1492-DR7	2		1492-DR7	2	
End Barrier: (Details Page 12-148)										
	End Anchors: (Details Page 12-146)									
	A-B Rail — Heavy Duty	1492-N23	10		1492-N23	10		1492-N23	10	
	A-B Rail — Normal Duty	1492-N47	50		—	—	—	1492-N47	50	
	A-B Rail—Retaining Clip—Light Duty	1492-N2	50		—	—	—	—	—	—
	DIN Rail — Normal Duty	1492-EA35	50		1492-EA35	50		1492-EA35	50	
	DIN Rail — Heavy Duty	1492-EAH35	50		1492-EAH35	50		1492-EAH35	50	
Jumpers: (Details Page 12-150)										
	2 Pole Uninsulated	1492-N42	50		1492-N42	50		—	—	—
	10 Pole Insulated	1492-SJ6-10	10		1492-SJ6-10	10		1492-SJ8-10	5	
	50 Pole Uninsulated	1492-N39	10		1492-N39	10		—	—	—
Marking Systems: (See Page 12-155)										
		1492-SMN81	5		1492-SMN81	5		1492-SMN81	5	

1492-H7

1492-WFB10HD

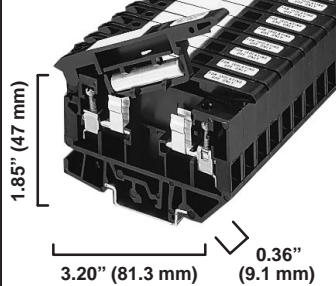
Dimensions are not intended for manufacturing purposes. Note: Height dimension is measured from top of rail to top of terminal block.						
Specifications	<i>High density isolating terminal block with finger-safe terminals.</i>	<i>Isolating terminal block.</i>				
Approvals (See Page 12-6)						
Voltage Rating	300V AC/DC	600V AC/DC				
Maximum Current	15A	30A				
Wire Range (Rated Cross Section)	#30-#12 AWG (0.05-4 mm ²)	#18-#8 AWG (0.5-10 mm ²)				
Wire Strip Length	0.38" (9.7 mm)	0.5" (12.7 mm)				
Recommended Tightening Torque	3-7 lb.-in. (0.3-0.8 Nm)	16-19 lb.-in. (1.80-2.14 Nm)				
Fuse Size (not supplied)	1/4" x 1-1/4" Dummy Fuse (supplied)	13/32" x 1-1/2" Dummy Fuse (supplied)				
Density	33 pcs./ft. (108/m)	17 pcs./ft. (58/m)				
Insulation Temperature Range	-40°C to +105°C	-40°C to +105°C				
Terminal Blocks	Catalog No.	Pcs./Pkg.	*	Catalog No.	Pcs./Pkg.	*
Terminal Block:	1492-H7	25		1492-WFB10HD	10	
Accessories	Catalog No.	Pcs./Pkg.	*	Catalog No.	Pcs./Pkg.	*
Mounting Rails: (Details Page 12-144) 3' Scored A-B Rail	1492-N1	20		1492-N1	20	
3' Rigid A-B Rail	1492-N22	20		1492-N22	20	
3' High Rise A-B Rail	1492-N44	2		1492-N44	2	
Standoff Brackets (use every 12")	1492-N25	2		1492-N25	2	
1 Meter Symmetrical DIN	199-DR1	10		199-DR1	10	
1 Meter Symmetrical DIN (alumin.)	1492-DR5	10		1492-DR5	10	
1 Meter Hi-Rise Symmetrical DIN	1492-DR6	2		1492-DR6	2	
1 Meter Angled Hi-Rise Sym. DIN	1492-DR7	2		1492-DR7	2	
End Barrier: (Details Page 12-148)	1492-N37	50		Not Required	—	—
End Anchors: (Details Page 12-146) A-B Rail — Heavy Duty	1492-N23	10		1492-N23	10	
A-B Rail — Normal Duty	1492-N47	50		1492-N47	50	
DIN Rail — Normal Duty	1492-EA35	50		1492-EA35	50	
DIN Rail — Heavy Duty	1492-EAH35	50		1492-EAH35	50	
Jumpers: (Details Page 12-150) 10 Pole Uninsulated	1492-N49	10		—	—	—
1 Meter Insulated	—	—	—	1492-SJ17-58	1	
Marking Systems: (See Page 12-155)	1492-SM8X12	5		1492-SMN83	5	

Bulletin 1492
Finger-Safe Terminal Blocks
Fuse Blocks

1492-H4

1492-H5

1492-H6

Dimensions are not intended for manufacturing purposes.

Note: Height dimension is measured from top of rail to top of terminal block.

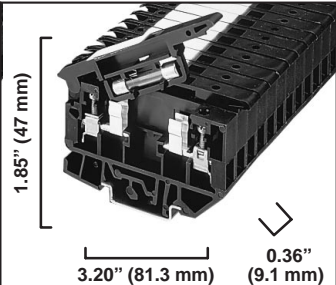
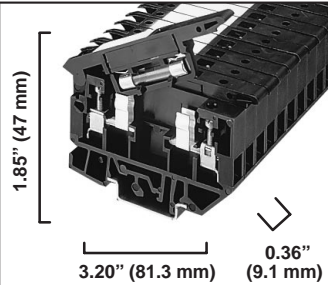
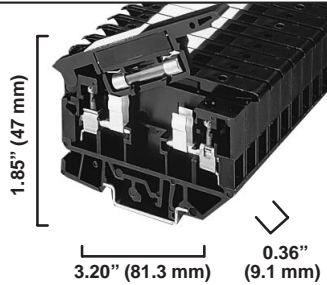

Specifications

Single circuit fusible terminal block with neon blown fuse indicator.

Single circuit fusible terminal block with LED blown fuse indicator.

Single circuit fusible terminal block without a blown fuse indicator.

Approvals (See Page 12-6)		CSA	IEC		CSA	IEC		CSA	IEC
Voltage Rating	300V AC/DC	300V AC/DC	500V AC/DC	300V AC/DC	300V AC/DC	500V AC/DC	300V AC/DC	300V AC/DC	500V AC/DC
Maximum Current	12A	12A	12A	12A	12A	12A	12A	12A	12A
Wire Range (Rated Cross Section)	#30-#12 AWG	#30-#12 AWG	0.05-4 mm ²	#30-#12 AWG	#30-#12 AWG	0.05-4 mm ²	#30-#12 AWG	#30-#12 AWG	0.05-4 mm ²
Indicator Type	Neon			LED			Non-Indicating		
Leakage Current	2mA @ 300V			2mA @ 24V			—		
Working Voltage	100-300V AC			10-57V AC/DC			Per Fuse Rating		
Fuse Size (Not Supplied)	1/4" x 1-1/4"			1/4" x 1-1/4"			1/4" x 1-1/4"		
Wire Strip Length	0.38" (9.7 mm)			0.38" (9.7 mm)			0.38" (9.7 mm)		
Recommended Tightening Torque	3-7 lb.-in. (0.3-0.8 Nm)			3-7 lb.-in. (0.3-0.8 Nm)			3-7 lb.-in. (0.3-0.8 Nm)		
Density	33 pcs./ft. (109/m)			33 pcs./ft. (109/m)			33 pcs./ft. (109/m)		
Insulation Temperature Range	-40°C to +105°C			-40°C to +105°C			-40°C to +105°C		

Terminal Blocks

	Catalog No.	Pcs./Pkg.	*	Catalog No.	Pcs./Pkg.	*	Catalog No.	Pcs./Pkg.	*
Terminal Block:	1492-H4	25		1492-H5	25		1492-H6	25	

Accessories

	Catalog No.	Pcs./Pkg.	*	Catalog No.	Pcs./Pkg.	*	Catalog No.	Pcs./Pkg.	*
Mounting Rails: (Details Page 12-144)									
3' Scored A-B Rail	1492-N1	20		1492-N1	20		1492-N1	20	
3' Rigid A-B Rail	1492-N22	20		1492-N22	20		1492-N22	20	
3' High Rise A-B Rail	1492-N44	2		1492-N44	2		1492-N44	2	
Standoff Brackets (Use Every 12")	1492-N25	2		1492-N25	2		1492-N25	2	
1 Meter Symmetrical DIN	199-DR1	10		199-DR1	10		199-DR1	10	
1 Meter Symmetrical DIN (Alumin.)	1492-DR5	10		1492-DR5	10		1492-DR5	10	
1 Meter Hi-Rise Symmetrical DIN	1492-DR6	2		1492-DR6	2		1492-DR6	2	
1 Meter Angled Hi-Rise Sym. DIN	1492-DR7	2		1492-DR7	2		1492-DR7	2	
End Barrier: (Details Page 12-148)	1492-N37	50		1492-N37	50		1492-N37	50	
End Anchors: (Details Page 12-146)									
A-B Rail — Heavy Duty	1492-N23	10		1492-N23	10		1492-N23	10	
A-B Rail — Normal Duty	1492-N47	50		1492-N47	50		1492-N47	50	
DIN Rail — Normal Duty	1492-EA35	50		1492-EA35	50		1492-EA35	50	
DIN Rail — Heavy Duty	1492-EAH35	50		1492-EAH35	50		1492-EAH35	50	
Jumpers: (Details Page 12-150)									
10 Pole Uninsulated	1492-N49	10		1492-N49	10		1492-N49	10	
Marking Systems: (See Page 12-155)	1492-SM8X12	5		1492-SM8X12	5		1492-SM8X12	5	

1492-UF3

<p>Dimensions are not intended for manufacturing purposes.</p> <p>Note: Height dimension is measured from top of rail to top of terminal block.</p>	
--	--

Specifications	<i>Fusible terminal block for GMT style fuse. Fuse block comes with fuse alarm circuit, finger-safe.</i>		
Approvals (See Page 12-6)			
Voltage Rating	125V AC, 60V DC		
Maximum Current	4A		
Wire Range (Rated Cross Section)	#30-#12 AWG (0.05-4 mm ²)		
Wire Strip Length	0.38" (9.7 mm)		
Recommended Tightening Torque	3-7 lb.-in. (0.3-0.8 Nm)		
Fuse Size (Not Supplied)	Bussmann "GMT" Type Alarm Fuse		
Leakage Current (Indicator Circuit)	—		
Density	40 pcs./ft. (131/m)		
Insulation Temperature Range	-40°C to +105°C		
Terminal Blocks	Catalog No.	Pcs./Pkg.	*
Terminal Block:	1492-UF3	40	
Accessories	Catalog No.	Pcs./Pkg.	*
Mounting Rails: (Details Page 12-144) 3' Scored A-B Rail	1492-N1	20	
3' Rigid A-B Rail	1492-N22	20	
3' High Rise A-B Rail	1492-N44	2	
Standoff Brackets (Use Every 12")	1492-N25	2	
1 Meter Symmetrical DIN	199-DR1	10	
1 Meter Symmetrical DIN (Alumin.)	1492-DR5	10	
1 Meter Hi-Rise Symmetrical DIN	1492-DR6	2	
1 Meter Angled Hi-Rise Sym. DIN	1492-DR7	2	
End Barrier: (Details Page 12-148)	Not Required	—	—
End Anchors: (Details Page 12-146) A-B Rail — Heavy Duty	1492-N23	10	
A-B Rail — Normal Duty	1492-N47	50	
DIN Rail — Normal Duty	1492-EA35	50	
DIN Rail — Heavy Duty	1492-EAH35	50	
Jumpers: (Details Page 12-150) 10 Pole Uninsulated	1492-N46	10	
Marking Systems: (See Page 12-154)	1492-N80	10	

Finger-Safe Terminal Blocks

Surge Suppressor Blocks

1492-HM2K024

1492-HM2K120

1492-HM2K240

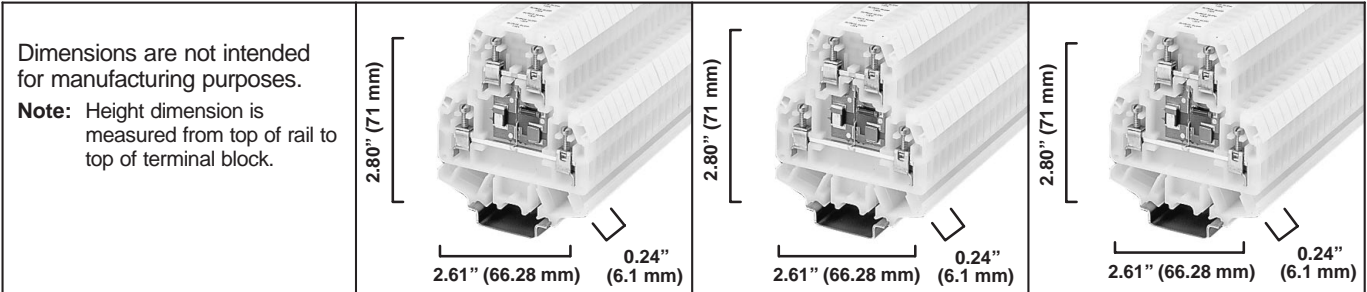

Dimensions are not intended for manufacturing purposes.
Note: Height dimension is measured from top of rail to top of terminal block.

Specifications	<i>Two circuit blocks consisting of a series resistor/capacitor connected in parallel with a metal oxide varistor (MOV). This device will suppress transient voltages developed by relay, contactor, and solenoid coils.</i>		
Approvals (See Page 12-6)			
Voltage Rating	24V AC/DC	120V AC/DC	240V AC/DC
Working Voltage	30V AC Max., 38V DC Max.	140V AC Max., 180V DC Max.	275V AC Max., 369V DC Max.
Maximum Current	24A (Busses)	24A (Busses)	24A (Busses)
Peak Current (8/20 μs Pulse)	250A	150A	150A
Leakage Current	1.0mA	4.5mA	10.0mA
Wire Range (Rated Cross Section)	#30-#12 AWG (0.05-4 mm ²)	#30-#12 AWG (0.05-4 mm ²)	#30-#12 AWG (0.05-4 mm ²)
Wire Strip Length	0.38" (9.7 mm)	0.38" (9.7 mm)	0.38" (9.7 mm)
Recommended Tightening Torque	3-7 lb.-in. (0.3-0.8 Nm)	3-7 lb.-in. (0.3-0.8 Nm)	3-7 lb.-in. (0.3-0.8 Nm)
Density	50 pcs./ft. (164/m)	50 pcs./ft. (164/m)	50 pcs./ft. (164/m)
Insulation Temperature Range	-40°C to +105°C	-40°C to +105°C	-40°C to +105°C

Terminal Blocks	Catalog No.	Pcs./Pkg.	*	Catalog No.	Pcs./Pkg.	*	Catalog No.	Pcs./Pkg.	*
Terminal Block:	1492-HM2K024 ^①	1		1492-HM2K120 ^①	1		1492-HM2K240 ^①	1	

Accessories	Catalog No.	Pcs./Pkg.	*	Catalog No.	Pcs./Pkg.	*	Catalog No.	Pcs./Pkg.	*
Mounting Rails: (Details Page 12-144)									
3' Scored A-B Rail	1492-N1	20		1492-N1	20		1492-N1	20	
3' Rigid A-B Rail	1492-N22	20		1492-N22	20		1492-N22	20	
3' High Rise A-B Rail	1492-N44	2		1492-N44	2		1492-N44	2	
Standoff Brackets (Use Every 12")	1492-N25	2		1492-N25	2		1492-N25	2	
1 Meter Symmetrical DIN	199-DR1	10		199-DR1	10		199-DR1	10	
1 Meter Symmetrical DIN (Alumin.)	1492-DR5	10		1492-DR5	10		1492-DR5	10	
1 Meter Hi-Rise Symmetrical DIN	1492-DR6	2		1492-DR6	2		1492-DR6	2	
1 Meter Angled Hi-Rise Sym. DIN	1492-DR7	2		1492-DR7	2		1492-DR7	2	
End Barrier: (Details Page 12-148)	1492-NM40	50		1492-NM40	50		1492-NM40	50	
End Anchors: (Details Page 12-146)									
A-B Rail — Heavy Duty	1492-N23	10		1492-N23	10		1492-N23	10	
DIN Rail — Normal Duty	1492-EA35	50		1492-EA35	50		1492-EA35	50	
DIN Rail — Heavy Duty	1492-EAH35	50		1492-EAH35	50		1492-EAH35	50	
Jumpers: (Details Page 12-150)									
2 Pole Insulated	1492-N42	50		1492-N42	50		1492-N42	50	
10 Pole Insulated	1492-SJ6-10	10		1492-SJ6-10	10		1492-SJ6-10	10	
50 Pole Uninsulated	1492-N39	10		1492-N39	10		1492-N39	10	
Marking Systems: (See Page 12-155)	1492-SMN81	5		1492-SMN81	5		1492-SMN81	5	

- ① This block is available with an "A-B Rail Only" mounting foot. Delete the "M" after the "H" in the catalog number. Package quantities are as shown on this page. Order accessories from the list under the 1492-H2 block on Page 12-53.
- ② See Page 12-170 for Component Specifications.

1492-HM2RA . . .

1492-HM2RB . . .

1492-HM2RC001

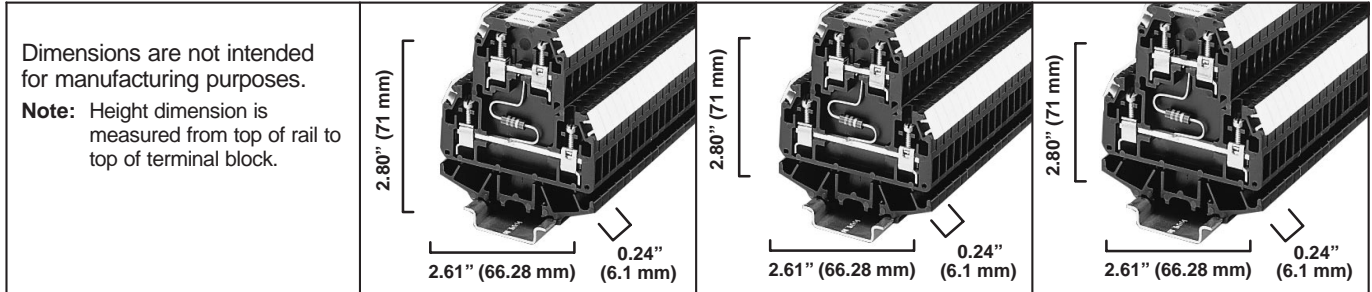

Specifications		<i>Two circuit block with a resistor between the upper and lower circuits. Block provides a means of connecting a resistor into control circuitry.</i>								
Approvals (See Page 12-6)										
Voltage Rating	600V AC/DC			600V AC/DC			600V AC/DC			
Working Voltage	300V ^①			250V ^①			250V ^①			
Maximum Current	24A (Busses), 0.25-0.5VA (Resistor) ^①			24A (Busses), 0.25VA (Resistor) ^①			24A (Busses), 0.5VA (Resistor) ^①			
Resistor Type	Carbon Fixed			Metal Oxide Film Resistor			Precision Wirewound Fixed Resistor			
Resistor Range	1.0-100M Ohms, 1/2 Watt			10 Ohms to 4.75 Meg ohms, 1/4 Watt			249 Ohm, 1/2 Watt			
Wire Range (Rated Cross Section)	#30-#12 AWG (0.05-4 mm ²)			#30-#12 AWG (0.05-4 mm ²)			#30-#12 AWG (0.05-4 mm ²)			
Wire Strip Length	0.38" (9.7 mm)			0.38" (9.7 mm)			0.38" (9.7 mm)			
Recommended Tightening Torque	3-7 lb.-in. (0.3-0.8 Nm)			3-7 lb.-in. (0.3-0.8 Nm)			3-7 lb.-in. (0.3-0.8 Nm)			
Density	50 pcs./ft. (164/m)			50 pcs./ft. (164/m)			50 pcs./ft. (164/m)			
Insulation Temperature Range	-40°C to +105°C			-40°C to +105°C			-40°C to +105°C			
Terminal Blocks	Catalog No.	Pcs./Pkg.	*	Catalog No.	Pcs./Pkg.	*	Catalog No.	Pcs./Pkg.	*	
Terminal Block:	1492-HM2RA... ^{①②③}	1		1492-HM2RB... ^{①③④}	1		1492-HM2RC001 ^{①③}	1		
Accessories	Catalog No.	Pcs./Pkg.	*	Catalog No.	Pcs./Pkg.	*	Catalog No.	Pcs./Pkg.	*	
Mounting Rails: (Details Page 12-144) 3' Scored A-B Rail	1492-N1	20		1492-N1	20		1492-N1	20		
3' Rigid A-B Rail	1492-N22	20		1492-N22	20		1492-N22	20		
3' High Rise A-B Rail	1492-N44	2		1492-N44	2		1492-N44	2		
Standoff Brackets (Use Every 12")	1492-N25	2		1492-N25	2		1492-N25	2		
1 Meter Symmetrical DIN	199-DR1	10		199-DR1	10		199-DR1	10		
1 Meter Symmetrical DIN (Alumin.)	1492-DR5	10		1492-DR5	10		1492-DR5	10		
1 Meter Hi-Rise Symmetrical DIN	1492-DR6	2		1492-DR6	2		1492-DR6	2		
1 Meter Angled Hi-Rise Sym. DIN	1492-DR7	2		1492-DR7	2		1492-DR7	2		
End Barrier: (Details Page 12-148)	1492-NM40	50		1492-NM40	50		1492-NM40	50		
End Anchors: (Details Page 12-146) A-B Rail — Heavy Duty	1492-N23	10		1492-N23	10		1492-N23	10		
DIN Rail — Normal Duty	1492-EA35	50		1492-EA35	50		1492-EA35	50		
DIN Rail — Heavy Duty	1492-EAH35	50		1492-EAH35	50		1492-EAH35	50		
Jumpers: (Details Page 12-150) 2 Pole Insulated	1492-N42	50		1492-N42	50		1492-N42	50		
10 Pole Insulated	1492-SJ6-10	10		1492-SJ6-10	10		1492-SJ6-10	10		
50 Pole Uninsulated	1492-N39	10		1492-N39	10		1492-N39	10		
Marking Systems: (See Page 12-155)	1492-SMN81	5		1492-SMN81	5		1492-SMN81	5		

- ① See Page 12-167 for Component Specifications.
- ② See Page 12-169 to select resistor value and complete the Catalog Number.
- ③ This block is available with an "A-B Rail Only" mounting foot. Delete the "M" after the "H" in the catalog number. Package quantities are as shown on this page. Order accessories from the list under the **1492-H2** block on Page 12-53.
- ④ See Page 12-168 to select resistor value and complete the Catalog Number.

Finger-Safe Terminal Blocks

Voltage Indicating Blocks

1492-HM2V24

1492-HM2V250

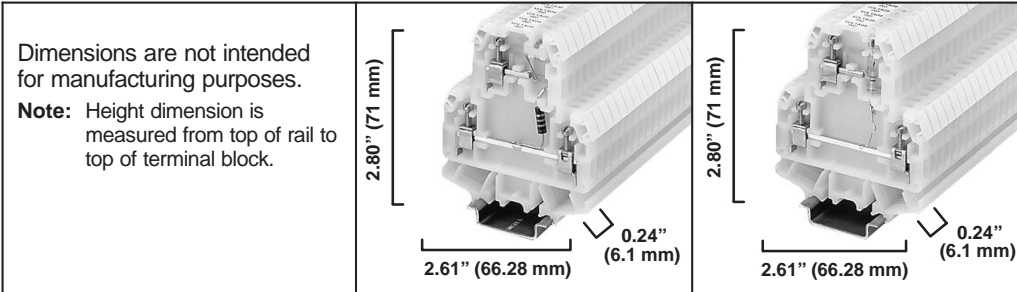

Dimensions are not intended for manufacturing purposes.
Note: Height dimension is measured from top of rail to top of terminal block.

Specifications	1492-HM2V24			1492-HM2V250		
	<i>Provides visual LED voltage indication across upper and lower terminals.</i>			<i>Provides visual neon AC voltage indication across upper and lower terminals.</i>		
Approvals (See Page 12-6)	UL/CSA			UL/CSA		
Voltage Rating	600V AC/DC			600V AC/DC		
Working Voltage	10-55V AC/DC (Indicator Circuit)			100-300V AC (Indicator Circuit)		
Maximum Current	24A (Busses)			24A (Busses)		
Indicator Type	LED			Neon		
Indicator Circuit Current	4.0mA @ 55V DC/0.6mA @ 10V DC			2.0mA @ 300V AC		
Wire Range (Rated Cross Section)	#30-#12 AWG (0.05-4 mm ²)			#30-#12 AWG (0.05-4 mm ²)		
Wire Strip Length	0.38" (9.7 mm)			0.38" (9.7 mm)		
Recommended Tightening Torque	3-7 lb.-in. (0.3-0.8 Nm)			3-7 lb.-in. (0.3-0.8 Nm)		
Density	50 pcs./ft. (164/m)			50 pcs./ft. (164/m)		
Insulation Temperature Range	-40°C to +105°C			-40°C to +105°C		
Terminal Blocks	Catalog No.	Pcs./Pkg.	*	Catalog No.	Pcs./Pkg.	*
Terminal Block:	1492-HM2V24 M	1		1492-HM2V250 M	1	
Accessories	Catalog No.	Pcs./Pkg.	*	Catalog No.	Pcs./Pkg.	*
Mounting Rails: (Details Page 12-144) 3' Scored A-B Rail	1492-N1	20		1492-N1	20	
3' Rigid A-B Rail	1492-N22	20		1492-N22	20	
3' High Rise A-B Rail	1492-N44	2		1492-N44	2	
Standoff Brackets (Use Every 12")	1492-N25	2		1492-N25	2	
1 Meter Symmetrical DIN	199-DR1	10		199-DR1	10	
1 Meter Symmetrical DIN (Alumin.)	1492-DR5	10		1492-DR5	10	
1 Meter Hi-Rise Symmetrical DIN	1492-DR6	2		1492-DR6	2	
1 Meter Angled Hi-Rise Sym. DIN	1492-DR7	2		1492-DR7	2	
End Barrier: (Details Page 12-148)	1492-NM40	50		1492-NM40	50	
End Anchors: (Details Page 12-146) A-B Rail — Heavy Duty	1492-N23	10		1492-N23	10	
DIN Rail — Normal Duty	1492-EA35	50		1492-EA35	50	
DIN Rail — Heavy Duty	1492-EAH35	50		1492-EAH35	50	
Jumpers: (Details Page 12-150) 2 Pole Insulated	1492-N42	50		1492-N42	50	
10 Pole Insulated	1492-SJ6-10	10		1492-SJ6-10	10	
50 Pole Uninsulated	1492-N39	10		1492-N39	10	
Marking Systems: (See Page 12-155)	1492-SMN81	5		1492-SMN81	5	

ⓘ This block is available with an "A-B Rail Only" mounting foot. Delete the "M" after the "H" in the catalog number. Package quantities are as shown on this page. Order accessories from the list under the 1492-H2 block on Page 12-53.

1492-HM2C

1492-HM2D

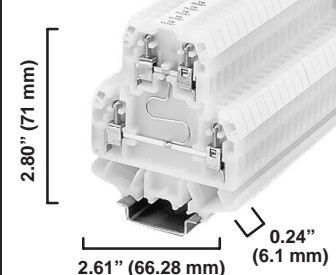
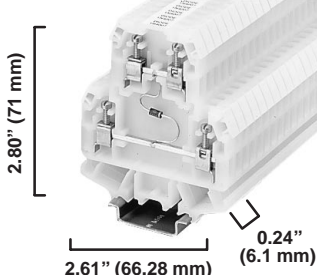
Dimensions are not intended for manufacturing purposes. Note: Height dimension is measured from top of rail to top of terminal block.						
Specifications	<i>Two circuit block with a shunt bar between the upper and lower circuits.</i>	<i>Two circuit block with a 1N4007 diode between the upper and lower circuits.</i>				
Approvals (See Page 12-6)	UL/CSA	UL/CSA				
Voltage Rating	600V AC/DC	600V AC/DC				
Working Voltage	600V AC/DC	600V AC/DC				
Maximum Current	10A	24A (Busses), 1A (Diode)				
Wire Range (Rated Cross Section)	#30-#12 AWG (0.05-4 mm ²)	#30-#12 AWG (0.05-4 mm ²)				
Wire Strip Length	0.38" (9.7 mm)	0.38" (9.7 mm)				
Recommended Tightening Torque	3-7 lb.-in. (0.3-0.8 Nm)	3-7 lb.-in. (0.3-0.8 Nm)				
Density	50 pcs./ft. (164/m)	50 pcs./ft. (164/m)				
Insulation Temperature Range	-40°C to +105°C	-40°C to +105°C				
Terminal Blocks	Catalog No.	Pcs./Pkg.	*	Catalog No.	Pcs./Pkg.	*
Terminal Block:	1492-HM2C ^①	1		1492-HM2D ^①	1	
Accessories	Catalog No.	Pcs./Pkg.	*	Catalog No.	Pcs./Pkg.	*
Mounting Rails: (Details Page 12-144)						
3' Scored A-B Rail	1492-N1	20		1492-N1	20	
3' Rigid A-B Rail	1492-N22	20		1492-N22	20	
3' High Rise A-B Rail	1492-N44	2		1492-N44	2	
Standoff Brackets (use every 12")	1492-N25	2		1492-N25	2	
1 Meter Symmetrical DIN	199-DR1	10		199-DR1	10	
1 Meter Symmetrical DIN (alumin.)	1492-DR5	10		1492-DR5	10	
1 Meter Hi-Rise Symmetrical DIN	1492-DR6	2		1492-DR6	2	
1 Meter Angled Hi-Rise Sym. DIN	1492-DR7	2		1492-DR7	2	
End Barrier: (Details Page 12-148)	1492-NM40	50		1492-NM40	50	
End Anchors: (Details Page 12-146)						
A-B Rail — Heavy Duty	1492-N23	10		1492-N23	10	
DIN Rail — Normal Duty	1492-EA35	50		1492-EA35	50	
DIN Rail — Heavy Duty	1492-EAH35	50		1492-EAH35	50	
Jumpers: (Details Page 12-150)						
2 Pole Insulated	1492-N42	50		1492-N42	50	
10 Pole Insulated	1492-SJ6-10	10		1492-SJ6-10	10	
50 Pole Uninsulated	1492-N39	10		1492-N39	10	
Marking Systems: (See Page 12-155)	1492-SMN81	5		1492-SMN81	5	

① This block is available with an "A-B Rail Only" mounting foot. Delete the "M" after the "H" in the catalog number. Package quantities are as shown on this page. Order accessories from the list under the **1492-H2** block on Page 12-53.

② See Page 12-167 for Component Specifications.

NOTES

Devices available in the Allen-Bradley NEMA/EEMAC^① line include Terminal Blocks, Isolation Switch Blocks, and Fuse Blocks.

Terminal Blocks:

Allen-Bradley NEMA/EEMAC terminal blocks are available in eleven colors for easy circuit identification. Colors and suggested uses are:

- RED for AC Control Circuits
- BLUE for DC Control Circuits
- BLACK for AC/DC Power Circuits
- ORANGE for Data Collection Circuits
- GREEN for Ground Circuits
- YELLOW for Externally Fed Circuits (Interlocks)
- BROWN for Miscellaneous Circuits
- VIOLET/GRAY to denote PLC Inputs and Outputs
- GOLD to match Some IEC Products
- WHITE for Neutral Circuits

Most NEMA/EEMAC blocks are available preassembled on a breakaway mounting channel, complete with one end-anchor, retaining clip and one end barrier.

Open Construction Terminal Blocks:

Open Construction blocks (Styles C and F) allow easy visual verification that the wire is properly positioned in the clamping area, and allows the use of a standard screwdriver for wiring. Style C and F blocks mount securely on Allen-Bradley rail. Catalog Number 1492–CAM blocks also mount on DIN rail. Several Style C blocks accept a snap on marker for marking long wire identifications. All Open Construction blocks have:

- Tin plated copper alloy conductors for corrosion resistance
- A write-on marking surface for easy circuit identification
- Optional marking strips to make mass markings easier

Isolation Switch Blocks:

- Allow easy, positive electrical circuit isolation
- Are available in both open and high density styles
- Feature a write-on marking surface for easy circuit identification

Fuse Blocks:

- Provides a simple way to add overcurrent protection into a circuit
- Can be used with the following fuse styles: 13/32" x 1-1/2", 1/4" x 1-1/4", and GMT-type alarm fuses. Blown fuse indicators are available on the 1/4" x 1-1/4" and 13/32" x 1-1/2" blocks. The indicator lights up when the fuse is blown, speeding troubleshooting. The GMT type fuse block has a visual alarm flag that also acts as an output contact for an electrical signal when the fuse is blown.

UL and CSA File Numbers:

NEMA/EEMAC Style Terminal Blocks have a 94-V2 flammability rating. The NEMA/EEMAC line is UL Component Recognized and CSA Certified.

- UL File Number E40735, Guide Number XCFR2
- UL File Number E34648, Guide Number IZLT2 (for Catalog Number 1492–CE6 only)
- CSA File Number LR67896, Class 622801

^① NEMA — National Electrical Manufacturer's Association
EEMAC — Electrical and Electronic Manufacturer's Association of Canada

NEMA/EEMAC Terminal Blocks

Open Construction Blocks

1492-F1

1492-F2

1492-F3

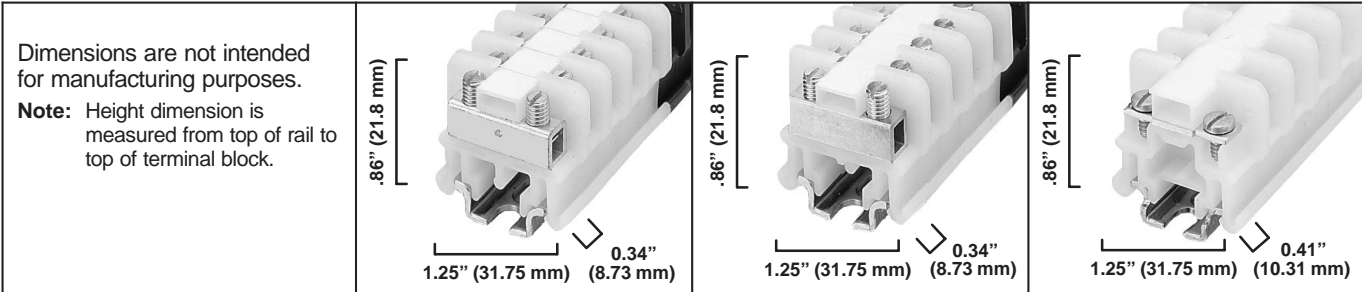

Dimensions are not intended for manufacturing purposes.
Note: Height dimension is measured from top of rail to top of terminal block.

Specifications	Terminal block, tubular screw with pressure plate.	Terminal block, tubular screw without pressure plate.	Terminal block, screw terminal with #6 screw.
Approvals (See Page 12-6)	UL/CSA	UL/CSA	UL/CSA
Voltage Rating	300V AC/DC	300V AC/DC	300V AC/DC
Maximum Current	25A	25A	25A
Wire Range (Rated Cross Section)	#22-#14 AWG (0.5-2.5 mm ²)	#22-#14 AWG (0.5-2.5 mm ²)	#22-#14 AWG (0.5-2.5 mm ²)
Wire Strip Length	0.38" (9.7 mm)	0.38" (9.7 mm)	Prepared Conductors Only ❶
Recommended Tightening Torque	4-14 lb.-in. (0.5-1.6 Nm)	6-14 lb.-in. (0.7-1.6 Nm)	6-14 lb.-in. (0.7-1.6 Nm)
Density	35 pcs./ft. (115/m)	35 pcs./ft. (115/m)	30 pcs./ft. (98/m)
Insulation Temperature Range	-40°C to +105°C	-40°C to +105°C	-40°C to +105°C

Terminal Blocks	Catalog No.	Pcs./Pkg.	*	Catalog No.	Pcs./Pkg.	*	Catalog No.	Pcs./Pkg.	*
Color: White	1492-F1	50		1492-F2	50		1492-F3	50	
Two 3' Rails White	1492-F1209 (105/Rail)	1		1492-F2209 (105/Rail)	1		1492-F3175 (88/Rail)	1	
Gold	1492-F1GL	50		1492-F2GL	50		1492-F3GL	50	
Red	1492-F1RE	50		1492-F2RE	50		1492-F3RE	50	
Blue	1492-F1B	50		1492-F2B	50		1492-F3B	50	
Black	1492-F1BL	50		1492-F2BL	50		1492-F3BL	50	
Green	1492-F1G	50		1492-F2G	50		1492-F3G	50	
Yellow	1492-F1Y	50		1492-F2Y	50		1492-F3Y	50	
Brown	1492-F1BR	50		1492-F2BR	50		1492-F3BR	50	
Violet	1492-F1VT	50		1492-F2VT	50		1492-F3VT	50	
Gray	1492-F1GY	50		1492-F2GY	50		1492-F3GY	50	
Orange	1492-F1OR	50		1492-F2OR	50		1492-F3OR	50	

Accessories	Catalog No.	Pcs./Pkg.	*	Catalog No.	Pcs./Pkg.	*	Catalog No.	Pcs./Pkg.	*
Mounting Rails: (Details Page 12-144) 3' Scored A-B Rail	1492-N1	20		1492-N1	20		1492-N1	20	
3' Rigid A-B Rail	1492-N22	20		1492-N22	20		1492-N22	20	
3' High Rise A-B Rail	1492-N44	2		1492-N44	2		1492-N44	2	
Standoff Brackets (Use Every 12")	1492-N25	2		1492-N25	2		1492-N25	2	
1 Meter Symmetrical DIN	—	—	—	—	—	—	—	—	—
1 Meter Symmetrical DIN (Alumin.)	—	—	—	—	—	—	—	—	—
1 Meter Hi-Rise Symmetrical DIN	—	—	—	—	—	—	—	—	—
1 Meter Angled Hi-Rise Sym. DIN	—	—	—	—	—	—	—	—	—
End Barrier: (Details Page 12-148)	1492-N18	50		1492-N18	50		1492-N18	50	
End Anchors: (Details Page 12-146) A-B Rail — Heavy Duty	1492-N23	10		1492-N23	10		1492-N23	10	
A-B Rail — Snap On	—	—	—	—	—	—	—	—	—
A-B Rail—Retaining Clip—Light Duty	1492-N2	50		1492-N2	50		1492-N2	50	
DIN Rail — Normal Duty	—	—	—	—	—	—	—	—	—
DIN Rail — Heavy Duty	—	—	—	—	—	—	—	—	—
Jumpers: (Details Page 12-150) 2 Pole Uninsulated	1492-N13	50		1492-N13	50		1492-N14	50	
50 Pole Uninsulated	1492-N24	10		1492-N24	10		—	—	—
Fanning Strip: (Details Page 12-150) (12 pole can cut to desired length)	—	—	—	—	—	—	—	—	—
Marking Systems: (See Page 12-154)	1492-N5 ❷	1		1492-N5 ❷	1		1492-N5 ❷	1	

❶ Prepared conductors utilize ring, spade, or hook connectors.

❷ 1 sheet, 20 strips.

1492-F8

1492-CA1

1492-CA1L

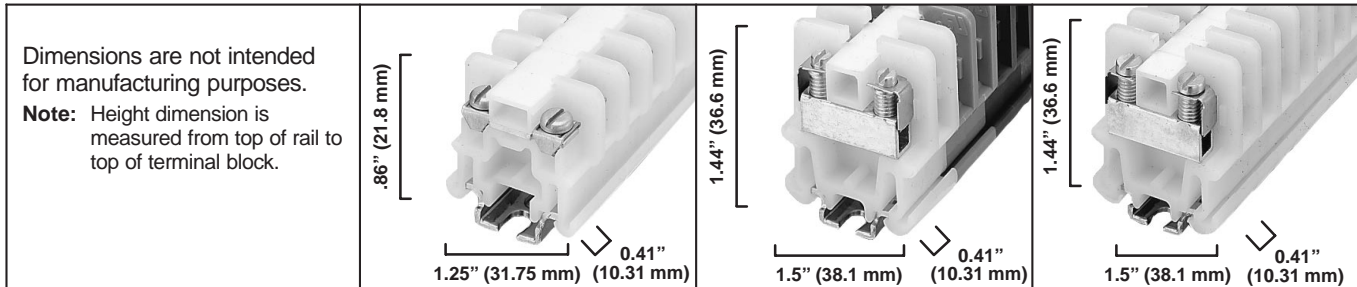

Dimensions are not intended for manufacturing purposes.
Note: Height dimension is measured from top of rail to top of terminal block.

Specifications	Terminal block, screw terminal with wire clamp.	Terminal block, tubular screw with pressure plate.	Terminal block, screw with large head, pressure plate.
Approvals (See Page 12-6)	UL/CSA	UL/CSA	UL/CSA
Voltage Rating	300V AC/DC	600V AC/DC	600V AC/DC
Maximum Current	25A	55A	55A
Wire Range (Rated Cross Section)	#22-#14 AWG (0.5-2.5 mm ²)	#22-#8 AWG (0.5-10 mm ²)	#22-#8 AWG (0.5-10 mm ²)
Wire Strip Length	0.25" (6.4 mm)	0.38" (9.7 mm)	0.38" (9.7 mm)
Recommended Tightening Torque	6-14 lb.-in. (0.7-1.6 Nm)	8-16 lb.-in. (0.9-1.8 Nm)	8-16 lb.-in. (0.9-1.8 Nm)
Density	30 pcs./ft. (98/m)	30 pcs./ft. (98/m)	30 pcs./ft. (98/m)
Insulation Temperature Range	-40°C to +105°C	-40°C to +105°C	-40°C to +105°C

Terminal Blocks	Catalog No.	Pcs./Pkg.	*	Catalog No.	Pcs./Pkg.	*	Catalog No.	Pcs./Pkg.	*
Color: White	1492-F8	50		1492-CA1	50		1492-CA1L	50	
Two 3' Rails White	1492-F8175 (88/Rail)	1		1492-CA1175 (88/Rail)	1		1492-CA1L175 (88/Rail)	1	
Gold	1492-F8GL	50		1492-CA1GL	50		1492-CA1LGL	50	
Red	1492-F8RE	50		1492-CA1RE	50		1492-CA1LRE	50	
Blue	1492-F8B	50		1492-CA1B	50		1492-CA1LB	50	
Black	1492-F8BL	50		1492-CA1BL	50		1492-CA1LBL	50	
Green	1492-F8G	50		1492-CA1G	50		1492-CA1LG	50	
Yellow	1492-F8Y	50		1492-CA1Y	50		1492-CA1LY	50	
Brown	1492-F8BR	50		1492-CA1BR	50		1492-CA1LBR	50	
Violet	1492-F8VT	50		1492-CA1VT	50		1492-CA1LVT	50	
Gray	1492-F8GY	50		1492-CA1GY	50		1492-CA1LGY	50	
Orange	1492-F8OR	50		1492-CA1OR	50		1492-CA1LOR	50	

Accessories	Catalog No.	Pcs./Pkg.	*	Catalog No.	Pcs./Pkg.	*	Catalog No.	Pcs./Pkg.	*
Mounting Rails: (Details Page 12-144) 3' Scored A-B Rail	1492-N1	20		1492-N1	20		1492-N1	20	
3' Rigid A-B Rail	1492-N22	20		1492-N22	20		1492-N22	20	
3' High Rise A-B Rail	1492-N44	2		1492-N44	2		1492-N44	2	
Standoff Brackets (Use Every 12")	1492-N25	2		1492-N25	2		1492-N25	2	
1 Meter Symmetrical DIN	—	—	—	—	—	—	—	—	—
1 Meter Symmetrical DIN (Alumin.)	—	—	—	—	—	—	—	—	—
1 Meter Hi-Rise Symmetrical DIN	—	—	—	—	—	—	—	—	—
1 Meter Angled Hi-Rise Sym. DIN	—	—	—	—	—	—	—	—	—
End Barrier: (Details Page 12-148)	1492-N18	50		1492-N16	50		1492-N16	50	
End Anchors: (Details Page 12-146) A-B Rail — Heavy Duty	1492-N23	10		1492-N23	10		1492-N23	10	
A-B Rail — Snap On	—	—	—	1492-N47	50		1492-N47	50	
A-B Rail—Retaining Clip—Light Duty	1492-N2	50		1492-N2	50		1492-N2	50	
DIN Rail — Normal Duty	—	—	—	—	—	—	—	—	—
DIN Rail — Heavy Duty	—	—	—	—	—	—	—	—	—
Jumpers: (Details Page 12-150) 2 Pole Uninsulated	1492-N14	50		1492-N3	50		1492-N3	50	
50 Pole Uninsulated	—	—	—	1492-N30	10		1492-N30	10	
Fanning Strip: (Details Page 12-150) (12 pole can cut to desired length)	—	—	—	1492-N20	1		1492-N20	1	
Marking Systems: (See Page 12-154)	1492-N5 ①	1		1492-N45	20		1492-N45	20	

① 1 sheet, 20 strips.

NEMA/EEMAC Terminal Blocks

Open Construction Blocks

1492-CAM1

1492-CAM1L

1492-CA2

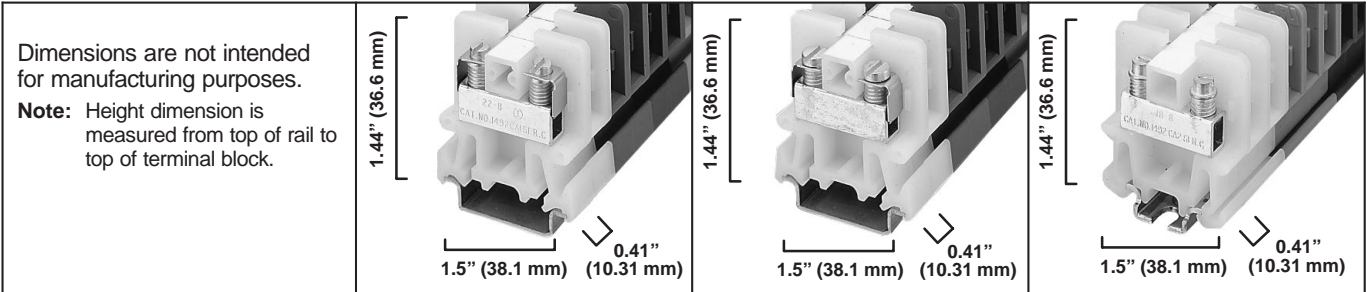

Dimensions are not intended for manufacturing purposes.
Note: Height dimension is measured from top of rail to top of terminal block.

Specifications	1492-CAM1	1492-CAM1L	1492-CA2
Terminal block, tubular screw with pressure plate, multi-rail mountable.	Terminal block, tubular screw with pressure plate, multi-rail mountable.	Terminal block, screw with large head, pressure plate, multi-rail mountable.	Terminal block, tubular screw without pressure plate.
Approvals (See Page 12-6)	UL/CSA	UL/CSA	UL/CSA
Voltage Rating	600V AC/DC	600V AC/DC	600V AC/DC
Maximum Current	55A	55A	55A
Wire Range (Rated Cross Section)	#22-#8 AWG (0.5-10 mm ²)	#22-#8 AWG (0.5-10 mm ²)	#18-#8 AWG (1-10 mm ²)
Wire Strip Length	0.38" (9.7 mm)	0.38" (9.7 mm)	0.38" (9.7 mm)
Recommended Tightening Torque	8-16 lb.-in. (0.9-1.8 Nm)	8-16 lb.-in. (0.9-1.8 Nm)	10-16 lb.-in. (1.1-1.8 Nm)
Density	30 pcs./ft. (98/m)	30 pcs./ft. (98/m)	30 pcs./ft. (98/m)
Insulation Temperature Range	-40°C to +105°C	-40°C to +105°C	-40°C to +105°C

Terminal Blocks	Catalog No.	Pcs./Pkg.	*	Catalog No.	Pcs./Pkg.	*	Catalog No.	Pcs./Pkg.	*
Color:	White	1492-CAM1	50	—	—	—	1492-CA2	50	—
	Two 3' Rails White	—	—	—	—	—	1492-CA2175 (88/Rail)	1	—
	Gold	1492-CAM1GL	50	1492-CAM1LGL	50	—	1492-CA2GL	50	—
	Red	1492-CAM1RE	50	1492-CAM1LRE	50	—	1492-CA2RE	50	—
	Blue	1492-CAM1B	50	1492-CAM1LB	50	—	1492-CA2B	50	—
	Black	1492-CAM1BL	50	1492-CAM1LBL	50	—	1492-CA2BL	50	—
	Green	1492-CAM1G	50	1492-CAM1LG	50	—	1492-CA2G	50	—
	Yellow	1492-CAM1Y	50	1492-CAM1LY	50	—	1492-CA2Y	50	—
	Brown	1492-CAM1BR	50	1492-CAM1LBR	50	—	1492-CA2BR	50	—
	Violet	1492-CAM1VT	50	1492-CAM1LVT	50	—	1492-CA2VT	50	—
	Gray	1492-CAM1GY	50	1492-CAM1LGY	50	—	1492-CA2GY	50	—
	Orange	1492-CAM1OR	50	1492-CAM1LOR	50	—	1492-CA2OR	50	—

Accessories	Catalog No.	Pcs./Pkg.	*	Catalog No.	Pcs./Pkg.	*	Catalog No.	Pcs./Pkg.	*
Mounting Rails: (Details Page 12-144)									
3' Scored A-B Rail	1492-N1	20	—	1492-N1	20	—	1492-N1	20	—
3' Rigid A-B Rail	1492-N22	20	—	1492-N22	20	—	1492-N22	20	—
3' High Rise A-B Rail	1492-N44	2	—	1492-N44	2	—	1492-N44	2	—
Standoff Brackets (Use Every 12")	1492-N25	2	—	1492-N25	2	—	1492-N25	2	—
1 Meter Symmetrical DIN	199-DR1	10	—	199-DR1	10	—	—	—	—
1 Meter Symmetrical DIN (Alumin.)	1492-DR5	10	—	1492-DR5	10	—	—	—	—
1 Meter Hi-Rise Symmetrical DIN	1492-DR6	2	—	1492-DR6	2	—	—	—	—
1 Meter Angled Hi-Rise Sym. DIN	1492-DR7	2	—	1492-DR7	2	—	—	—	—
End Barrier: (Details Page 12-148)	1492-NM16	50	—	1492-NM16	50	—	1492-N16	50	—
End Anchors: (Details Page 12-146)									
A-B Rail — Heavy Duty	1492-N23	10	—	1492-N23	10	—	1492-N23	10	—
A-B Rail — Snap On	1492-N47	50	—	1492-N47	50	—	1492-N47	50	—
A-B Rail—Retaining Clip—Light Duty	1492-N2	50	—	1492-N2	50	—	1492-N2	50	—
DIN Rail — Normal Duty	1492-EA35	50	—	1492-EA35	50	—	—	—	—
DIN Rail — Heavy Duty	1492-EAH35	50	—	1492-EAH35	50	—	—	—	—
Jumpers: (Details Page 12-150)									
2 Pole Uninsulated	1492-N3	50	—	1492-N3	50	—	1492-N3	50	—
50 Pole Uninsulated	1492-N30	10	—	1492-N30	10	—	1492-N30	10	—
Fanning Strip: (Details Page 12-150)									
(12 pole can cut to desired length)	1492-N20	1	—	1492-N20	1	—	1492-N20	1	—
Marking Systems: (See Page 12-154)	1492-N45	20	—	1492-N45	20	—	1492-N45	20	—

1492-CAM2

1492-CD2

1492-CE2

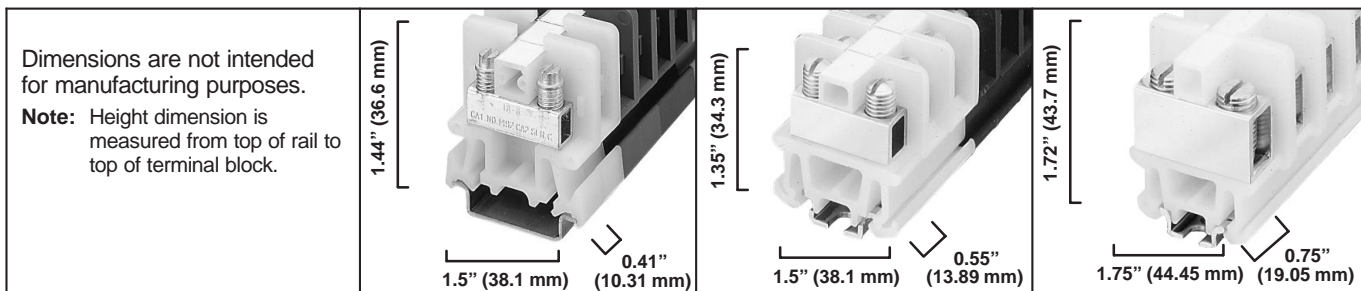

Dimensions are not intended for manufacturing purposes.
Note: Height dimension is measured from top of rail to top of terminal block.

Specifications	1492-CAM2	1492-CD2	1492-CE2
Terminal block, tubular screw without pressure plate, multi-rail mountable.	Terminal block, tubular screw without pressure plate.	Terminal block, tubular screw without pressure plate.	Terminal block, tubular screw without pressure plate.
Approvals (See Page 12-6)			
Voltage Rating	600V AC/DC	600V AC/DC	600V AC/DC
Maximum Current	55A	100A	195A
Wire Range (Rated Cross Section)	#18-#8 AWG (1-10 mm ²)	#14-#4 AWG (2.5-25 mm ²)	#12-#1/0 AWG (4-50 mm ²)
Wire Strip Length	0.38" (9.7 mm)	0.44" (11.2 mm)	0.69" (17.5 mm)
Recommended Tightening Torque	10-16 lb.-in. (1.1-1.8 Nm)	16-30 lb.-in. (1.8-3.4 Nm)	50 lb.-in. (5.6 Nm)
Density	30 pcs./ft. (98/m)	22 pcs./ft. (72/m)	16 pcs./ft. (52/m)
Insulation Temperature Range	-40°C to +105°C	-40°C to +105°C	-40°C to +105°C

Terminal Blocks	Catalog No.	Pcs./Pkg.	*	Catalog No.	Pcs./Pkg.	*	Catalog No.	Pcs./Pkg.	*
Color:	White	1492-CAM2	50	—	—	—	1492-CD2	50	—
	Two 3' Rails White	—	—	—	1492-CD2130 (65/Rail)	1	—	—	—
	Gold	1492-CAM2GL	50	—	1492-CD2GL	50	—	1492-CE2GL	10
	Red	1492-CAM2RE	50	—	1492-CD2RE	50	—	1492-CE2RE	10
	Blue	1492-CAM2B	50	—	1492-CD2B	50	—	1492-CE2B	10
	Black	1492-CAM2BL	50	—	1492-CD2BL	50	—	1492-CE2BL	10
	Green	1492-CAM2G	50	—	1492-CD2G	50	—	1492-CE2G	10
	Yellow	1492-CAM2Y	50	—	1492-CD2Y	50	—	1492-CE2Y	10
	Brown	1492-CAM2BR	50	—	1492-CD2BR	50	—	1492-CE2BR	10
	Violet	1492-CAM2VT	50	—	1492-CD2VT	50	—	1492-CE2VT	10
	Gray	1492-CAM2GY	50	—	1492-CD2GY	50	—	1492-CE2GY	10
	Orange	1492-CAM2OR	50	—	1492-CD2OR	50	—	1492-CE2OR	10

Accessories	Catalog No.	Pcs./Pkg.	*	Catalog No.	Pcs./Pkg.	*	Catalog No.	Pcs./Pkg.	*
Mounting Rails: (Details Page 12-144)									
3' Scored A-B Rail	1492-N1	20	—	1492-N1	20	—	1492-N1	20	—
3' Rigid A-B Rail	1492-N22	20	—	1492-N22	20	—	1492-N22	20	—
3' High Rise A-B Rail	1492-N44	2	—	1492-N44	2	—	1492-N44	2	—
Standoff Brackets (Use Every 12")	1492-N25	2	—	1492-N25	2	—	1492-N25	2	—
1 Meter Symmetrical DIN	199-DR1	10	—	—	—	—	—	—	—
1 Meter Symmetrical DIN (Alumin.)	1492-DR5	10	—	—	—	—	—	—	—
1 Meter Hi-Rise Symmetrical DIN	1492-DR6	2	—	—	—	—	—	—	—
1 Meter Angled Hi-Rise Sym. DIN	1492-DR7	2	—	—	—	—	—	—	—
End Barrier: (Details Page 12-148)	1492-NM16	50	—	1492-N16	50	—	1492-N17	50	—
End Anchors: (Details Page 12-146)									
A-B Rail — Heavy Duty	1492-N23	10	—	1492-N23	10	—	1492-N23	10	—
A-B Rail — Snap On	1492-N47	50	—	1492-N47	50	—	1492-N47	50	—
A-B Rail—Retaining Clip—Light Duty	1492-N2	50	—	—	—	—	—	—	—
DIN Rail — Normal Duty	1492-EA35	50	—	—	—	—	—	—	—
DIN Rail — Heavy Duty	1492-EAH35	50	—	—	—	—	—	—	—
Jumpers: (Details Page 12-150)									
2 Pole Uninsulated	1492-N3	50	—	—	—	—	1492-N21	10	—
50 Pole Uninsulated	1492-N30	10	—	—	—	—	—	—	—
Fanning Strip: (Details Page 12-150)	1492-N20	1	—	—	—	—	—	—	—
(12 pole can cut to desired length)									
Marking Systems: (See Page 12-154)	1492-N45	20	—	1492-N8	25	—	1492-N8	25	—

NEMA/EEMAC Terminal Blocks

Open Construction Blocks

1492-CA3

1492-CD3

1492-CD8

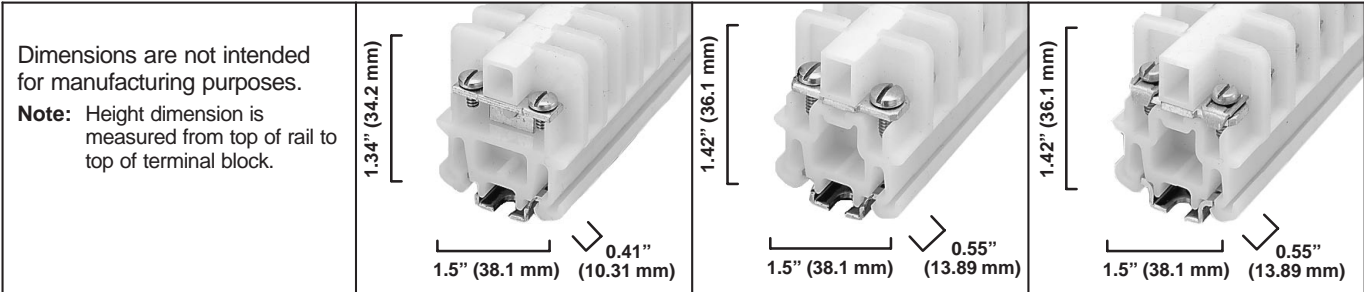

Specifications	<i>Terminal block, screw terminal with #6 screw.</i>	<i>Terminal block, screw terminal with #8 screw.</i>	<i>Terminal block, screw terminal with wire clamp.</i>
Approvals (See Page 12-6)	/CSA	/CSA	/CSA
Voltage Rating	600V AC/DC	600V AC/DC	600V AC/DC
Maximum Current	20A	35A	35A
Wire Range (Rated Cross Section)	#22-#14 AWG (0.5-2.5 mm ²)	#22-#10 AWG (0.5-6 mm ²)	#22-#10 AWG (0.5-6 mm ²)
Wire Strip Length	Prepared Conductors Only	Prepared Conductors Only	0.38" (9.7 mm)
Recommended Tightening Torque	12 lb.-in. (1.4 Nm)	10-16 lb.-in. (1.1-1.8 Nm)	10-16 lb.-in. (1.1-1.8 Nm)
Density	30 pcs./ft. (98/m)	22 pcs./ft. (72/m)	22 pcs./ft. (72/m)
Insulation Temperature Range	-40°C to +105°C	-40°C to +105°C	-40°C to +105°C

Terminal Blocks	Catalog No.	Pcs./Pkg.	*	Catalog No.	Pcs./Pkg.	*	Catalog No.	Pcs./Pkg.	*
Color:	White	1492-CA3	50		1492-CD3	50		1492-CD8	50
	Two 3' Rails White	1492-CA3175 (88/Rail)	1		1492-CD3130 (65/Rail)	1		1492-CD8130 (65/Rail)	1
	Gold	1492-CA3GL	50		1492-CD3GL	50		1492-CD8GL	50
	Red	1492-CA3RE	50		1492-CD3RE	50		1492-CD8RE	50
	Blue	1492-CA3B	50		1492-CD3B	50		1492-CD8B	50
	Black	1492-CA3BL	50		1492-CD3BL	50		1492-CD8BL	50
	Green	1492-CA3G	50		1492-CD3G	50		1492-CD8G	50
	Yellow	1492-CA3Y	50		1492-CD3Y	50		1492-CD8Y	50
	Brown	1492-CA3BR	50		1492-CD3BR	50		1492-CD8BR	50
	Violet	1492-CA3VT	50		1492-CD3VT	50		1492-CD8VT	50
	Gray	1492-CA3GY	50		1492-CD3GY	50		1492-CD8GY	50
	Orange	1492-CA3OR	50		1492-CD3OR	50		1492-CD8OR	50

Accessories	Catalog No.	Pcs./Pkg.	*	Catalog No.	Pcs./Pkg.	*	Catalog No.	Pcs./Pkg.	*
Mounting Rails: (Details Page 12-144)									
3' Scored A-B Rail	1492-N1	20		1492-N1	20		1492-N1	20	
3' Rigid A-B Rail	1492-N22	20		1492-N22	20		1492-N22	20	
3' High Rise A-B Rail	1492-N44	2		1492-N44	2		1492-N44	2	
Standoff Brackets (Use Every 12")	1492-N25	2		1492-N25	2		1492-N25	2	
1 Meter Symmetrical DIN	—	—	—	—	—	—	—	—	—
1 Meter Symmetrical DIN (Alumin.)	—	—	—	—	—	—	—	—	—
1 Meter Hi-Rise Symmetrical DIN	—	—	—	—	—	—	—	—	—
1 Meter Angled Hi-Rise Sym. DIN	—	—	—	—	—	—	—	—	—
End Barrier: (Details Page 12-148)	1492-N16	50		1492-N16	50		1492-N16	50	
End Anchors: (Details Page 12-146)									
A-B Rail — Heavy Duty	1492-N23	10		1492-N23	10		1492-N23	10	
A-B Rail — Snap On	1492-N47	50		1492-N47	50		1492-N47	50	
A-B Rail—Retaining Clip—Light Duty	1492-N2	50		1492-N2	50		1492-N2	50	
DIN Rail — Normal Duty	—	—	—	—	—	—	—	—	—
DIN Rail — Heavy Duty	—	—	—	—	—	—	—	—	—
Jumpers: (Details Page 12-150)									
2 Pole Uninsulated	1492-N14	50		1492-N15	50		1492-N15	50	
50 Pole Uninsulated	—	—	—	—	—	—	—	—	—
Fanning Strip: (Details Page 12-150)	—	—	—	—	—	—	—	—	—
(12 pole can cut to desired length)	—	—	—	—	—	—	—	—	—
Marking Systems: (See Page 12-154)	1492-N8	25		1492-N8	25		1492-N8	25	

Prepared conductors utilize ring, spade, or hook connectors.

1492-CE9

1492-H7

1492-WFB10HD

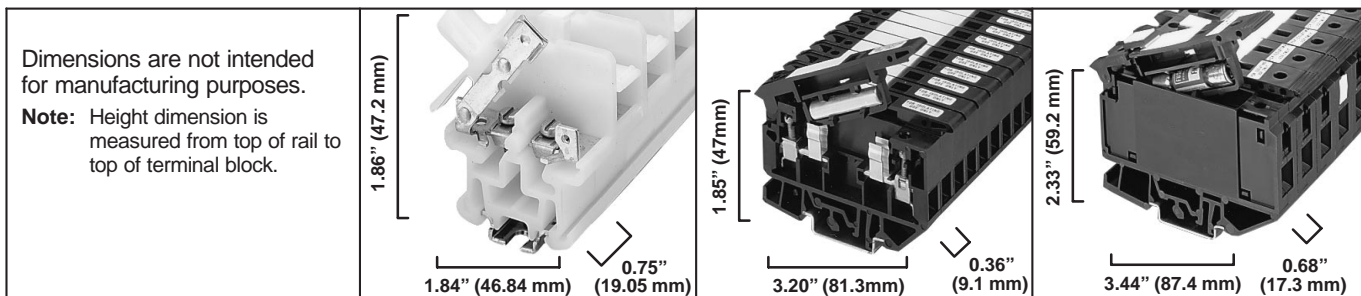

Specifications	1492-CE9	1492-H7	1492-WFB10HD
	<i>Knife disconnect isolating terminal block with screw terminal and wire clamp.</i>	<i>High density isolating terminal block with finger-safe terminals.</i>	<i>Isolating terminal block.</i>
Approvals (See Page 12-6)	UL/CSA	UL/CSA/IEC	UL/CSA/IEC
Voltage Rating	600V AC/DC	300V AC/DC	600V AC/DC
Maximum Current	10A	15A	30A
Wire Range (Rated Cross Section)	#22-#10 AWG (0.5-6 mm ²)	#30-#12 AWG (0.05-4 mm ²)	#18-#8 AWG (0.5-10 mm ²)
Wire Strip Length	0.38" (9.7 mm)	0.38" (9.7 mm)	0.5" (12.7 mm)
Recommended Tightening Torque	10-16 lb.-in. (1.1-1.8 Nm)	3-7 lb.-in. (0.3-0.8 Nm)	16-19 lb.-in. (1.80-2.14 Nm)
Fuse Size (Not Supplied)	—	1/4" x 1-1/4" Dummy Fuse (supplied)	13/32" x 1-1/2" Dummy Fuse (supplied)
Density	16 pcs./ft. (52/m)	33 pcs./ft. (108/m)	17 pcs./ft. (58/m)
Insulation Temperature Range	-40°C to +105°C	-40°C to +105°C	-40°C to +105°C

Terminal Blocks	Catalog No.	Pcs./Pkg.	*	Catalog No.	Pcs./Pkg.	*	Catalog No.	Pcs./Pkg.	*
Terminal Block:	1492-CE9	10		1492-H7	25		1492-WFB10HD	10	
Accessories	Catalog No.	Pcs./Pkg.	*	Catalog No.	Pcs./Pkg.	*	Catalog No.	Pcs./Pkg.	*
Mounting Rails: (Details Page 12-144) 3' Scored A-B Rail	1492-N1	20		1492-N1	20		1492-N1	20	
3' Rigid A-B Rail	1492-N22	20		1492-N22	20		1492-N22	20	
3' High Rise A-B Rail	1492-N44	2		1492-N44	2		1492-N44	2	
Standoff Brackets (Use Every 12")	1492-N25	2		1492-N25	2		1492-N25	2	
1 Meter Symmetrical DIN	—	—	—	199-DR1	10		199-DR1	10	
1 Meter Symmetrical DIN (Alumin.)	—	—	—	1492-DR5	10		1492-DR5	10	
1 Meter Hi-Rise Symmetrical DIN	—	—	—	1492-DR6	2		1492-DR6	2	
1 Meter Angled Hi-Rise Sym. DIN	—	—	—	1492-DR7	2		1492-DR7	2	
End Barrier: (Details Page 12-148)	1492-N17	50		1492-N37	50		Not Required	—	—
End Anchors: (Details Page 12-146) A-B Rail — Heavy Duty	1492-N23	10		1492-N23	10		1492-N23	10	
A-B Rail — Snap On	1492-N47	50		1492-N47	50		1492-N47	50	
DIN Rail — Normal Duty	—	—	—	1492-EA35	50		1492-EA35	50	
DIN Rail — Heavy Duty	—	—	—	1492-EAH35	50		1492-EAH35	50	
Jumpers: (Details Page 12-150) 10 Pole Uninsulated	—	—	—	1492-N49	10		—	—	—
1 Meter Insulated	—	—	—	—	—	—	1492-SJ17-58	1	
Marking Systems: (See Page 12-155)	—	—	—	1492-SM8X12	5		1492-SMN83	10	

NEMA/EEMAC Terminal Blocks

Fuse Blocks

1492-WFB10

1492-WFB1024

1492-WFB10250

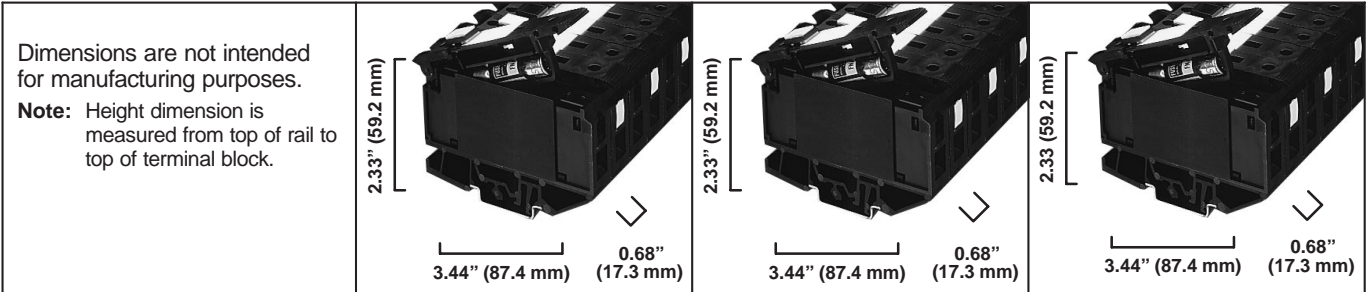

Dimensions are not intended for manufacturing purposes. Note: Height dimension is measured from top of rail to top of terminal block.									
Specifications	Fusible terminal block for 13/32" x 1-1/2" fuse.			Fusible terminal block for 13/32" x 1-1/2" fuse with LED blown fuse indicator.			Fusible terminal block for 13/32" x 1-1/2" fuse with neon blown fuse indicator.		
Approvals (See Page 12-6)		CSA	IEC		CSA	IEC		CSA	IEC
Voltage Rating	600V AC/DC	600V AC/DC	800V AC/DC	600V AC/DC	600V AC/DC	800V AC/DC	600V AC/DC	600V AC/DC	800V AC/DC
Maximum Current	30A	30A	30A	30A	30A	30A	30A	30A	30A
Wire Range (Rated Cross Section)	#18-#8 AWG	#18-#8 AWG	0.5-10 mm ²	#18-#8 AWG	#18-#8 AWG	0.5-10 mm ²	#18-#8 AWG	#18-#8 AWG	0.5-10 mm ²
Wire Strip Length	0.5" (12.7 mm)			0.5" (12.7 mm)			0.5" (12.7 mm)		
Recommended Tightening Torque	16-19 lb.-in. (1.8-2.14 Nm)			16-19 lb.-in. (1.8-2.14 Nm)			16-19 lb.-in. (1.8-2.14 Nm)		
Indicator Type	Non-Indicating			LED			Neon		
Working Voltage	Per Fuse Rating			10-57V AC/DC			100-300V AC		
Leakage Current (Indicator Circuit)	—			2mA @ 24V			2mA @ 300V		
Fuse Size (Not Supplied)	13/32" x 1-1/2" Fuse			13/32" x 1-1/2" Fuse			13/32" x 1-1/2" Fuse		
Density	17 pcs./ft. (58/m)			17 pcs./ft. (58/m)			17 pcs./ft. (58/m)		
Insulation Temperature Range	-40°C to +105°C			-40°C to +105°C			-40°C to +105°C		
Terminal Blocks	Catalog No.	Pcs./Pkg.	*	Catalog No.	Pcs./Pkg.	*	Catalog No.	Pcs./Pkg.	*
Terminal Block:	1492-WFB10	10		1492-WFB1024	10		1492-WFB10250	10	
Accessories	Catalog No.	Pcs./Pkg.	*	Catalog No.	Pcs./Pkg.	*	Catalog No.	Pcs./Pkg.	*
Mounting Rails: (Details Page 12-144) 3' Scored A-B Rail	1492-N1	20		1492-N1	20		1492-N1	20	
3' Rigid A-B Rail	1492-N22	20		1492-N22	20		1492-N22	20	
3' High Rise A-B Rail	1492-N44	2		1492-N44	2		1492-N44	2	
Standoff Brackets (Use Every 12")	1492-N25	2		1492-N25	2		1492-N25	2	
1 Meter Symmetrical DIN	199-DR1	10		199-DR1	10		199-DR1	10	
1 Meter Symmetrical DIN (Alumin.)	1492-DR5	10		1492-DR5	10		1492-DR5	10	
1 Meter Hi-Rise Symmetrical DIN	1492-DR6	2		1492-DR6	2		1492-DR6	2	
1 Meter Angled Hi-Rise Sym. DIN	1492-DR7	2		1492-DR7	2		1492-DR7	2	
End Barrier: (Details Page 12-148)	Not Required	—	—	Not Required	—	—	Not Required	—	—
End Anchors: (Details Page 12-146) A-B Rail — Heavy Duty	1492-N23	10		1492-N23	10		1492-N23	10	
A-B Rail — Snap On	1492-N47	50		1492-N47	50		1492-N47	50	
DIN Rail — Normal Duty	1492-EA35	50		1492-EA35	50		1492-EA35	50	
DIN Rail — Heavy Duty	1492-EAH35	50		1492-EAH35	50		1492-EAH35	50	
Jumpers: (Details Page 12-150) 10 Pole Uninsulated	—	—	—	—	—	—	—	—	—
1 Meter Insulated	1492-SJ17-58	1		1492-SJ17-58	1		1492-SJ17-58	1	
Marking Systems: (See Page 12-155)	1492-SMN83	10		1492-SMN83	10		1492-SMN83	10	

1492-H4

1492-H5

1492-H6

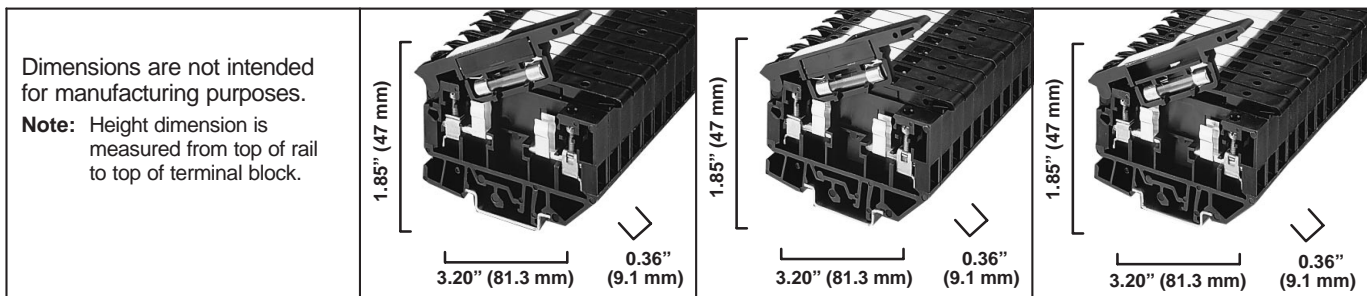

Specifications	1492-H4			1492-H5			1492-H6					
	Single circuit fusible terminal block with neon blown fuse indicator.	Single circuit fusible terminal block with LED blown fuse indicator.	Single circuit fusible terminal block without a blown fuse indicator.	Approvals (See Page 12-6)	CSA	IEC	Approvals (See Page 12-6)	CSA	IEC	Approvals (See Page 12-6)	CSA	IEC
Approvals (See Page 12-6)		CSA	IEC		CSA	IEC		CSA	IEC		CSA	IEC
Voltage Rating	300V AC/DC	300V AC/DC	500V AC/DC	300V AC/DC	300V AC/DC	500V AC/DC	300V AC/DC	300V AC/DC	500V AC/DC	300V AC/DC	300V AC/DC	500V AC/DC
Maximum Current	12A	12A	12A	12A	12A	12A	12A	12A	12A	12A	12A	12A
Wire Range (Rated Cross Section)	#30-#12 AWG	#30-#12 AWG	0.05-4 mm ²	#30-#12 AWG	#30-#12 AWG	0.05-4 mm ²	#30-#12 AWG	#30-#12 AWG	0.05-4 mm ²	#30-#12 AWG	#30-#12 AWG	0.05-4 mm ²
Indicator Type	Neon			LED			Non-Indicating					
Leakage Current	2mA @ 300V			2mA @ 24V			—					
Working Voltage	100-300V AC			10-57V AC/DC			Per Fuse Rating					
Fuse Size (Not Supplied)	1/4" x 1-1/4"			1/4" x 1-1/4"			1/4" x 1-1/4"					
Wire Strip Length	0.38" (9.7 mm)			0.38" (9.7 mm)			0.38" (9.7 mm)					
Recommended Tightening Torque	3-7 lb.-in. (0.3-0.8 Nm)			3-7 lb.-in. (0.3-0.8 Nm)			3-7 lb.-in. (0.3-0.8 Nm)					
Density	33 pcs./ft. (109/m)			33 pcs./ft. (109/m)			33 pcs./ft. (109/m)					
Insulation Temperature Range	-40°C to +105°C			-40°C to +105°C			-40°C to +105°C					
Terminal Blocks	Catalog No.	Pcs./Pkg.	*	Catalog No.	Pcs./Pkg.	*	Catalog No.	Pcs./Pkg.	*			
Terminal Block:	1492-H4	25		1492-H5	25		1492-H6	25				
Accessories	Catalog No.	Pcs./Pkg.	*	Catalog No.	Pcs./Pkg.	*	Catalog No.	Pcs./Pkg.	*			
Mounting Rails: (Details Page 12-144) 3' Scored A-B Rail	1492-N1	20		1492-N1	20		1492-N1	20				
3' Rigid A-B Rail	1492-N22	20		1492-N22	20		1492-N22	20				
3' High Rise A-B Rail	1492-N44	2		1492-N44	2		1492-N44	2				
Standoff Brackets (Use Every 12")	1492-N25	2		1492-N25	2		1492-N25	2				
1 Meter Symmetrical DIN	199-DR1	10		199-DR1	10		199-DR1	10				
1 Meter Symmetrical DIN (Alumin.)	1492-DR5	10		1492-DR5	10		1492-DR5	10				
1 Meter Hi-Rise Symmetrical DIN	1492-DR6	2		1492-DR6	2		1492-DR6	2				
1 Meter Angled Hi-Rise Sym. DIN	1492-DR7	2		1492-DR7	2		1492-DR7	2				
End Barrier: (Details Page 12-148)	1492-N37	50		1492-N37	50		1492-N37	50				
End Anchors: (Details Page 12-146) A-B Rail — Heavy Duty	1492-N23	10		1492-N23	10		1492-N23	10				
A-B Rail — Snap On	1492-N47	50		1492-N47	50		1492-N47	50				
DIN Rail — Normal Duty	1492-EA35	50		1492-EA35	50		1492-EA35	50				
DIN Rail — Heavy Duty	1492-EAH35	50		1492-EAH35	50		1492-EAH35	50				
Jumpers: (Details Page 12-150) 10 Pole Uninsulated	1492-N49	10		1492-N49	10		1492-N49	10				
Marking Systems: (See Page 12-155)	1492-SM8X12	5		1492-SM8X12	5		1492-SM8X12	5				

1492-CE6

1492-UF3

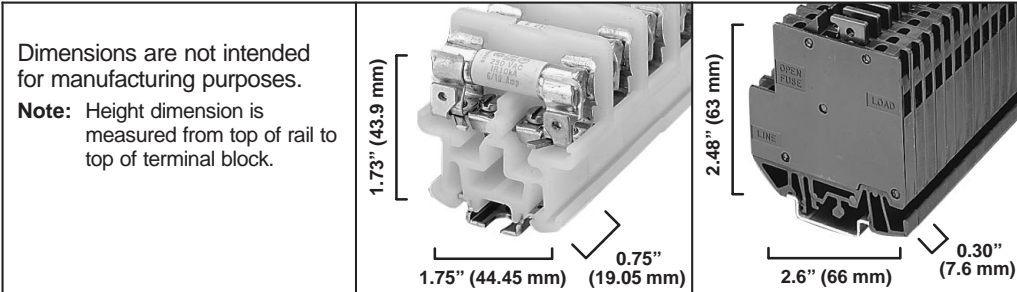

Dimensions are not intended for manufacturing purposes.
Note: Height dimension is measured from top of rail to top of terminal block.

Specifications	<i>13/32" x 1-1/2" fuse block with screw terminals and wire clamp.</i>			<i>GMT style fuse block with blown fuse alarm circuit, finger-safe.</i>		
Approvals (See Page 12-6)	UL/CSA			UL		
Voltage Rating	600V AC/DC			125V AC, 60V DC		
Maximum Current	10A			4A		
Wire Range (Rated Cross Section)	#22-#10 AWG (0.5-6 mm ²)			#30-#12 AWG (0.05-4 mm ²)		
Wire Strip Length	0.38" (9.7 mm)			0.38" (9.7 mm)		
Recommended Tightening Torque	10-16 lb.-in. (1.1-1.8 Nm)			3-7 lb.-in. (0.3-0.8 Nm)		
Fuse Size (Not Supplied)	13/32" x 1-1/2" Fuse			Bussmann "GMT" Type Alarm Fuse		
Leakage Current (Indicator Circuit)	—			—		
Density	16 pcs./ft. (52/m)			40 pcs./ft. (131/m)		
Insulation Temperature Range	-40°C to +105°C			-40°C to +105°C		
Terminal Blocks	Catalog No.	Pcs./Pkg.	*	Catalog No.	Pcs./Pkg.	*
Terminal Block:	1492-CE6	10		1492-UF3	40	
Terminal Block: Two 3' Rails White	1492-CE695 (48/Rail)	1		—	—	
Accessories	Catalog No.	Pcs./Pkg.	*	Catalog No.	Pcs./Pkg.	*
Mounting Rails: (Details Page 12-144) 3' Scored A-B Rail	1492-N1	20		1492-N1	20	
3' Rigid A-B Rail	1492-N22	20		1492-N22	20	
3' High Rise A-B Rail	1492-N44	2		1492-N44	2	
Standoff Brackets (Use Every 12")	1492-N25	2		1492-N25	2	
1 Meter Symmetrical DIN	—	—	—	199-DR1	10	
1 Meter Symmetrical DIN (Alumin.)	—	—	—	1492-DR5	10	
1 Meter Hi-Rise Symmetrical DIN	—	—	—	1492-DR6	2	
1 Meter Angled Hi-Rise Sym. DIN	—	—	—	1492-DR7	2	
End Barrier: (Details Page 12-148)	1492-N17	50		Not Required	—	—
End Anchors: (Details Page 12-146) A-B Rail — Heavy Duty	1492-N23	10		1492-N23	10	
A-B Rail — Snap On	1492-N47	50		1492-N47	50	
DIN Rail — Normal Duty	—	—	—	1492-EA35	50	
DIN Rail — Heavy Duty	—	—	—	1492-EAH35	50	
Jumpers: (Details Page 12-150) 10 Pole Uninsulated	—	—	—	1492-N46	10	
Fuse Puller: (Details Page 12-151)	1492-N12	50		—	—	—
Marking Systems: (See Page 12-154)	—	—	—	1492-N80	10	

Allen-Bradley Panel Mount Blocks are most often used when the installation requires only a few terminations. Designed to save on installation time, Allen-Bradley Panel Mount Blocks are ready to wire after mounting, no rail is needed. Available in four different styles and seven different types, the wide variety meets the needs of most applications.

Catalog Number 1492–HC6 blocks feature six poles in a two-inch long, finger-safe design. The Catalog Number 1492–HC6 has an interlocking feature which saves space in multi-block installations. Mounting screws are included.

Other Panel Mount Block Styles Include:





- Multiple Barrier Strip (Catalog Numbers 1492–HJ86, 1492–HJ812), for simple connection of solid or stranded wires, 6 or 12 poles.
- Pull-apart Blocks (Catalog Numbers 1492–EC85, 1492–ED103), which allow the disconnection of multiple poles at once, are available in three or five pole versions and are used extensively in Motor Control Centers.
- High Temperature Dovetail Blocks (Catalog Numbers 1492–15T, 1492–25T), capable of handling up to 150°C. These blocks have a dovetail design which allows multiple poles to be interlocked. They require only two fastening points every 12 blocks.

Note: Panel Mount terminal blocks come standard with a write-on marking surface for easy product identification. All Panel Mount Blocks are made of materials with a 94-V2 flammability rating except Catalog Numbers 1492–15T and 1492–25T, which are made of 94-V0 material.

Note: Most Panel Mount Blocks are UL Component Recognized and CSA Certified. Look for “UL” or “CSA” in the product specifications.

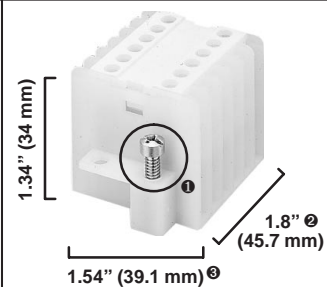
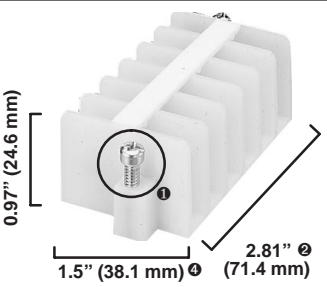
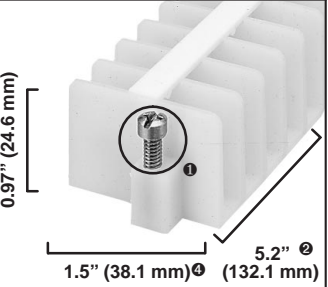
- UL File Number E40735, Guide Number XCFR2
- CSA File Number LR67896, Class 622801

Bulletin 1492
Panel Mount Blocks

	1492-HC6	1492-HJ86	1492-HJ812						
Dimensions are not intended for manufacturing purposes.									
Specifications	<i>High density 6 pole panel mount terminal block. Can be interconnected to make 12 and 18 pole units.</i>	<i>Standard 6 pole panel mount block. Screw terminal with wire clamp.</i>	<i>Standard 12 pole panel mount block. Screw terminal with wire clamp.</i>						
Approvals (See Page 12-6)									
Voltage Rating	600V AC/DC	600V AC/DC	600V AC/DC						
Maximum Current (per pole)	25A	25A	25A						
Wire Range (Rated Cross Section)	#30-#12 AWG (0.05-4 mm ²)	#18-#12 AWG (1-4 mm ²)	#18-#12 AWG (1-4 mm ²)						
Wire Strip Length	0.38" (9.7 mm)	0.38" (9.7 mm)	0.38" (9.7 mm)						
Recommended Tightening Torque	3-7 lb.-in. (0.3-0.8 Nm)	8-16 lb.-in. (0.9-1.8 Nm)	8-16 lb.-in. (0.9-1.8 Nm)						
Insulation Temperature Range	-40°C to +105°C	-40°C to +105°C	-40°C to +105°C						
Terminal Blocks	Catalog No.	Pcs./ Pkg.	*	Catalog No.	Pcs./ Pkg.	*	Catalog No.	Pcs./ Pkg.	*
Terminal Block:	1492-HC6	1		1492-HJ86	1		1492-HJ812	1	
Accessories	Catalog No.	Pcs./ Pkg.	*	Catalog No.	Pcs./ Pkg.	*	Catalog No.	Pcs./ Pkg.	*
Jumpers: (Details Page 12-150) 2 Pole Uninsulated	1492-N38	50		1492-N35	50		1492-N35	50	
50 Pole Uninsulated	1492-N39	10		—	—		—	—	
Anchor Unit: (Details Page 12-146) (required every 12th block)	Not Required	—		Not Required	—		Not Required	—	
End Piece: (Details Page 12-146)	Not Required	—		Not Required	—		Not Required	—	

- ❶ #8-32 screw.
- ❷ Measurement between mounting screw centers.
- ❸ Mounting screws are offset 0.31" (7.9 mm) from centerline.
- ❹ Mounting screws are offset 0.19" (4.76 mm) from centerline.

1492-15T

1492-25T

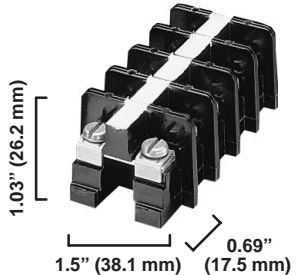
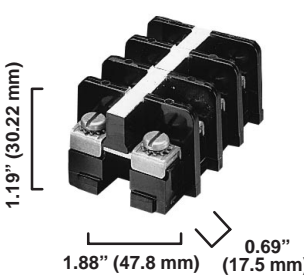
<p>Dimensions are not intended for manufacturing purposes.</p>						
<p>Specifications</p>	<p><i>High temperature one pole panel mount block, wire clamp. Gangable for multi-pole installation.</i></p>	<p><i>High temperature one pole panel mount block, wire clamp. Gangable for multi-pole installation.</i></p>				
<p>Voltage Rating</p>	<p>600V AC/DC</p>	<p>600V AC/DC</p>				
<p>Maximum Current (per pole)</p>	<p>35A</p>	<p>45A</p>				
<p>Wire Range (Rated Cross Section)</p>	<p>#16-#12 AWG (1.5-4 mm²)</p>	<p>#16-#10 AWG (1.5-6 mm²)</p>				
<p>Wire Strip Length</p>	<p>0.38" (9.7 mm)</p>	<p>0.38" (9.7 mm)</p>				
<p>Recommended Tightening Torque</p>	<p>10-16 lb.-in. (1.1-1.8 Nm)</p>	<p>10-16 lb.-in. (1.1-1.8 Nm)</p>				
<p>Insulation Temperature Range</p>	<p>-40°C to +149°C</p>	<p>-40°C to +149°C</p>				
<p>Terminal Blocks</p>	<p>Catalog No.</p>	<p>Pcs./ Pkg.</p>	<p>*</p>	<p>Catalog No.</p>	<p>Pcs./ Pkg.</p>	<p>*</p>
<p>Terminal Block:</p>	<p>1492-15T</p>	<p>100</p>	<p></p>	<p>1492-25T</p>	<p>100</p>	<p></p>
<p>Accessories</p>	<p>Catalog No.</p>	<p>Pcs./ Pkg.</p>	<p>*</p>	<p>Catalog No.</p>	<p>Pcs./ Pkg.</p>	<p>*</p>
<p>Anchor Unit: (Details Page 12-146) (required every 12th block)</p>	<p>1492-15A</p>	<p>10</p>	<p></p>	<p>1492-25A</p>	<p>10</p>	<p></p>
<p>End Piece: (Details Page 12-146)</p>	<p>1492-15E</p>	<p>25</p>	<p></p>	<p>1492-25E</p>	<p>25</p>	<p></p>

Bulletin 1492
Panel Mount Blocks

1492-EC85

1492-ED103

Dimensions are not intended for manufacturing purposes.						
	<p>5 pole terminal block. Pulls apart to disconnect all poles from the circuit.</p>			<p>3 pole terminal block. Pulls apart to disconnect all poles from the circuit.</p>		
Specifications						
Approvals (See Page 12-6)	UL/CSA			UL/CSA		
Voltage Rating	600V AC/DC			600V AC/DC		
Maximum Current (per pole)	25A			60A		
Wire Range (Rated Cross Section)	#20-#12 AWG (0.75-4 mm ²)			#14-#4 AWG (2.5-25 mm ²)		
Wire Strip Length	0.38" (9.7 mm)			0.38" (9.7 mm)		
Recommended Tightening Torque	6-16 lb.-in. (0.7-1.8 Nm)			10-30 lb.-in. (1.1-3.4 Nm)		
Insulation Temperature Range	-40°C to +105°C			-40°C to +105°C		
Terminal Blocks	Catalog No.	Pcs./Pkg.	*	Catalog No.	Pcs./Pkg.	*
Terminal Block:	1492-EC85	1		1492-ED103	1	
Accessories	Catalog No.	Pcs./Pkg.	*	Catalog No.	Pcs./Pkg.	*
Anchor Unit: (Details Page 12-146) (required every 12th block)	Not Required	—	—	Not Required	—	—
End Piece: (Details Page 12-146)	Not Required	—	—	Not Required	—	—

① #8-32 screw.

The broad line of Allen-Bradley Power Blocks are designed to meet most application needs. Power Blocks feature easy circuit marking (all but 1492-PDM mini-style blocks have a write-on marking surface). In addition, mounting dimensions are provided with each unit and wire ranges and tightening torques are labeled on the product to simplify installation.

Four Styles of Power Blocks are Available

Mini Blocks:

- Rated at 600V AC/DC, 115A; these blocks offer high current carrying capacity in a very small package to save on panel space
- Two configurations available: 3 pole feed through with 1 line opening and 1 load opening per pole; 3 pole power distribution with 1 line opening and 4 load openings per pole

3 Pole Power Distribution Blocks With

Aluminum Connectors:

- Ideal for distributing power to multiple loads
- Rated at 600V AC/DC, 175–760A
- 1 or 2 line openings per pole, 4, 6, 8, or 12 load openings per pole

Feed Through/Splicer Blocks With

Aluminum Connectors:

- Allow easy connection of field wiring to a cabinet
- Rated at 600V AC/DC, 175–760A
- 1 and 3 pole configurations
- 1 line opening, 1 load opening per pole (2 line/2 load for higher current applications)



Power Distribution and Feed Through



Blocks With Copper Connectors:



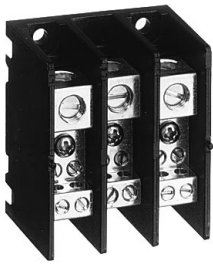

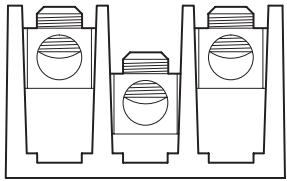
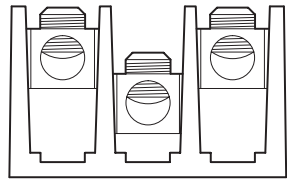
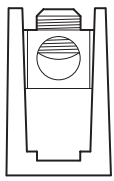
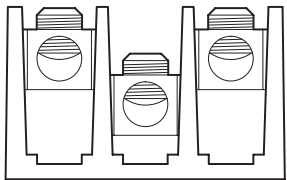
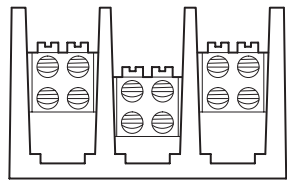
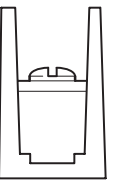
- Meet the copper-only standard for the automotive industry
- Rated at 600V AC/DC, 175–760A
- 1 and 3 pole configurations

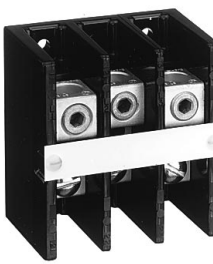
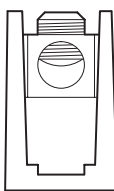
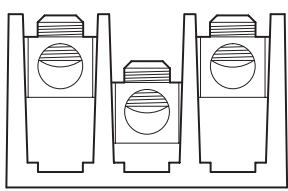
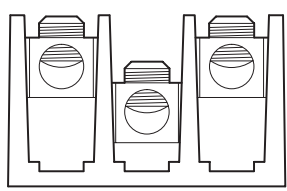
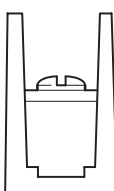
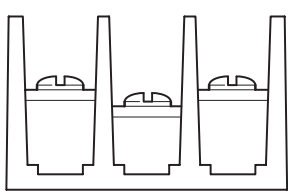
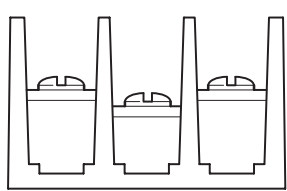

Power Blocks are UL Component Recognized and CSA Certified.

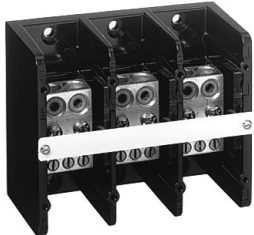
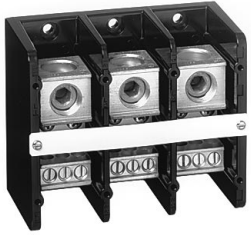
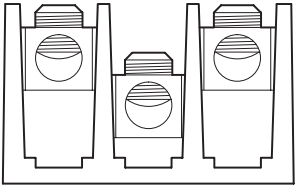
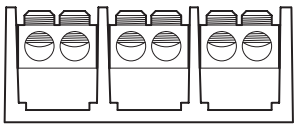
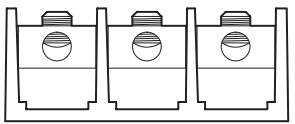
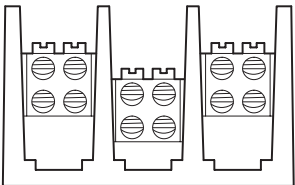
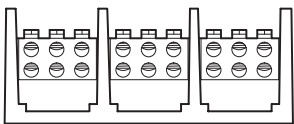
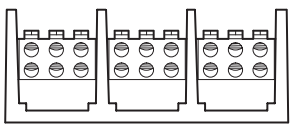





- UL File Number E40735, Guide Number XCFR2
- CSA File Number LR19766, Class 905204

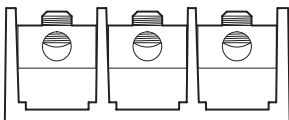
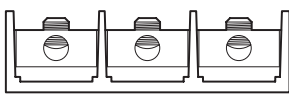
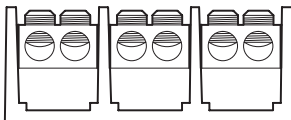
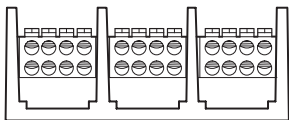
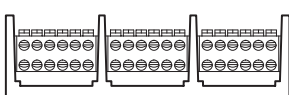
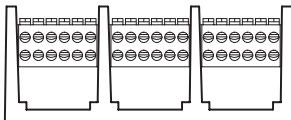

	1492-PDM3111			1492-PDM3141			1492-50YF		
									
	Line			Line			Line		
									
	Load			Load			Load		
									
Specifications	<i>PDM Mini Style</i>			<i>PDM Mini Style</i>			<i>Tap with Binding Screw</i>		
Approvals (See Page 12-6)	UL/CSA			UL/CSA			UL/CSA		
Current Rating (per pole)	115A			115A			175A		
Voltage Rating (per pole)	600V AC/DC			600V AC/DC			600V AC/DC		
Number of Poles	3 Pole			3 Pole			1 Pole		
Insulating Material Max. Temperature Rating	125°C			125°C			150°C		
Flammability Rating	94V-O			94V-O			94V-O		
Terminal Blocks	Catalog No.	Pcs./ Pkg.	*	Catalog No.	Pcs./ Pkg.	*	Catalog No.	Pcs./ Pkg.	*
Terminal Block:	1492-PDM3111	1		1492-PDM3141	1		1492-50YF	1	
Block Characteristics	Line	Load		Line	Load		Line	Load	
Openings Per Pole	1	1		1	4		1	1	
Wire Range (AWG)	#2-14	#2-14		#2-14	#10-18		#2/0-14	1/4" Tap with Binding Screw	
Rated Cross Section (mm ²)	35-2.5	35-2.5		35-2.5	6-0.75		70-2.5		
Tightening Torque Range (also on block by specific wire size)	35-50 lb.-in. (4.0-5.6 Nm)	35-50 lb.-in. (4.0-5.6 Nm)		35-50 lb.-in. (4.0-5.6 Nm)	7 lb.-in. (0.79 Nm)		35-120 lb.-in. (4.0-13.5 Nm)	35 lb.-in. (4.0 Nm)	
Marking Strip	None Provided			None Provided			Single White Strip		
Connector Material	Aluminum			Aluminum			Aluminum		
Dimensions	See Page 12-88			See Page 12-88			See Page 12-88		

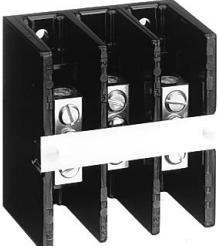
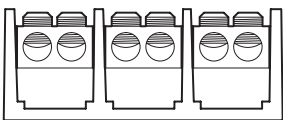
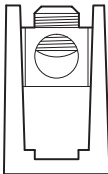
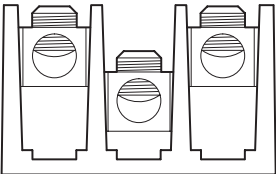
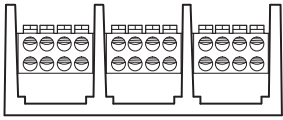
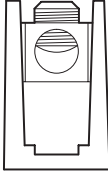
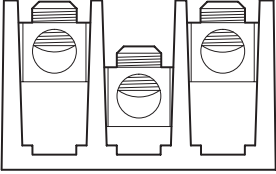

	1492-100YF			1492-50XF			1492-100XF		
									
	Line			Line			Line		
									
	Load			Load			Load		
									
Specifications	Tap with Binding Screw			Tap with Binding Screw			Tap with Binding Screw		
Approvals (See Page 12-6)	UL/CSA			UL/CSA			UL/CSA		
Current Rating (per pole)	175A			175A			175A		
Voltage Rating (per pole)	600V AC/DC			600V AC/DC			600V AC/DC		
Number of Poles	1 Pole			3 Pole			3 Pole		
Insulating Material Max. Temperature Rating	150°C			150°C			150°C		
Flammability Rating	94V-O			94V-O			94V-O		
Terminal Blocks	Catalog No.	Pcs./ Pkg.	*	Catalog No.	Pcs./ Pkg.	*	Catalog No.	Pcs./ Pkg.	*
Terminal Block:	1492-100YF	1		1492-50XF	1		1492-100XF	1	
Block Characteristics	Line	Load		Line	Load		Line	Load	
Openings Per Pole	1	1		1	1		1	1	
Wire Range (AWG)	#2/0-14	1/4" Tap with Binding Screw		#2/0-14	1/4" Tap with Binding Screw		#2/0-14	1/4" Tap with Binding Screw	
Rated Cross Section (mm ²)	70-2.5			70-2.5			70-2.5		
Tightening Torque Range (also on block by specific wire size)	35-120 lb.-in. (4.0-13.5 Nm)	35 lb.-in. (4.0 Nm)		35-120 lb.-in. (4.0-13.5 Nm)	35 lb.-in. (4.0 Nm)		35-120 lb.-in. (4.0-13.5 Nm)	35 lb.-in. (4.0 Nm)	
Marking Strip	Single White Strip			Single White Strip			Single White Strip		
Connector Material	Aluminum			Aluminum			Aluminum		
Dimensions	See Page 12-88			See Page 12-88			See Page 12-88		

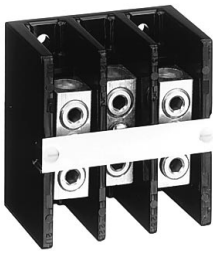

	1492-PD3141			1492-PD3263			1492-PD3163		
									
	Line			Line			Line		
									
	Load			Load			Load		
									
Specifications	<i>Power Distribution Block</i>			<i>Power Distribution Block</i>			<i>Power Distribution Block</i>		
Approvals (See Page 12-6)									
Current Rating (per pole)	175A			350A			335A		
Voltage Rating (per pole)	600V AC/DC			600V AC/DC			600V AC/DC		
Number of Poles	3 Pole			3 Pole			3 Pole		
Insulating Material Max. Temperature Rating	150°C			150°C			150°C		
Flammability Rating	94V-O			94V-O			94V-O		
Terminal Blocks	Catalog No.	Pcs./ Pkg.	*	Catalog No.	Pcs./ Pkg.	*	Catalog No.	Pcs./ Pkg.	*
Terminal Block:	1492-PD3141	1		1492-PD3263	1		1492-PD3163	1	
Block Characteristics	Line	Load		Line	Load		Line	Load	
Openings Per Pole	1	4		2	6		1	6	
Wire Range (AWG)	#2/0-14	#4-14		#2/0-14	#4-14		400kcmil-#6 AWG	#2-14	
Rated Cross Section (mm ²)	70-2.5	25-2.5		70-2.5	25-2.5		185-16	35-2.5	
Tightening Torque Range (also on block by specific wire size)	35-120 lb.-in. (4.0-13.5 Nm)	35-45 lb.-in. (4.0-5.1 Nm)		35-120 lb.-in. (4.0-13.5 Nm)	35-45 lb.-in. (4.0-5.1 Nm)		275 lb.-in. (31.1 Nm)	35-50 lb.-in. (4.0-5.6 Nm)	
Marking Strip	Single White Strip			Single White Strip			Single White Strip		
Connector Material	Aluminum			Aluminum			Aluminum		
Dimensions	See Page 12-88			See Page 12-88			See Page 12-88		

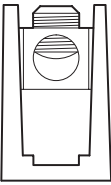
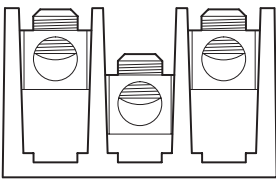
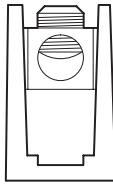
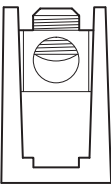
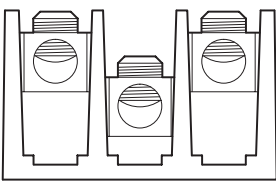
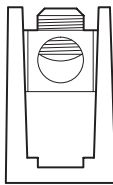

	1492-PD3183			1492-PD31123			1492-PD32127		
									
	Line			Line			Line		
									
	Load			Load			Load		
									
Specifications	<i>Power Distribution Block</i>			<i>Power Distribution Block</i>			<i>Power Distribution Block</i>		
Approvals (See Page 12-6)	UL/CSA			UL/CSA			UL/CSA		
Current Rating (per pole)	335A			380A			760A		
Voltage Rating (per pole)	600V AC/DC			600V AC/DC			600V AC/DC		
Number of Poles	3 Pole			3 Pole			3 Pole		
Insulating Material Max. Temperature Rating	150°C			150°C			150°C		
Flammability Rating	94V-O			94V-O			94V-O		
Terminal Blocks	Catalog No.	Pcs./ Pkg.	*	Catalog No.	Pcs./ Pkg.	*	Catalog No.	Pcs./ Pkg.	*
Terminal Block:	1492-PD3183	1		1492-PD31123	1		1492-PD32127	1	
Block Characteristics	Line	Load		Line	Load		Line	Load	
Openings Per Pole	1	8		1	12		2	12	
Wire Range (AWG)	400kcmil- #6 AWG	#2-14		500kcmil- #4 AWG	#2-14		500kcmil- #4 AWG	#4-14	
Rated Cross Section (mm ²)	185-16	35-2.5		240-25	35-2.5		240-25	25-2.5	
Tightening Torque Range (also on block by specific wire size)	275 lb.-in. (31.1 Nm)	35-50 lb.-in. (4.0-5.6 Nm)		375 lb.-in. (42.4 Nm)	35-50 lb.-in. (4.0-5.6 Nm)		375 lb.-in. (42.4 Nm)	35-45 lb.-in. (4.0-5.1 Nm)	
Marking Strip	Single White Strip			Single White Strip			Single White Strip		
Connector Material	Aluminum			Aluminum			Aluminum		
Dimensions	See Page 12-88			See Page 12-88			See Page 12-88		

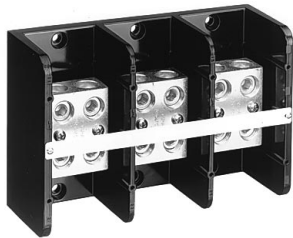
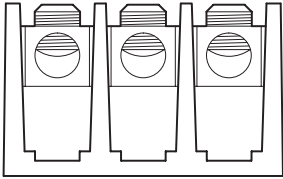
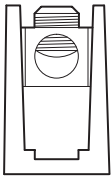
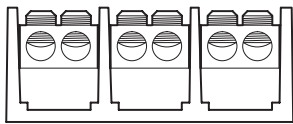
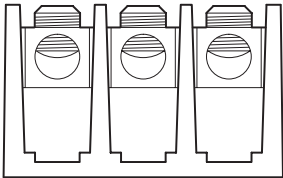
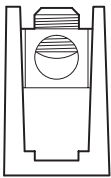
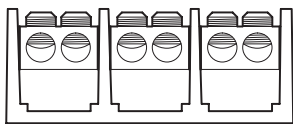
	1492-PD3287			1492-50Y			1492-50X		
									
	Line			Line			Line		
									
	Load			Load			Load		
									
Specifications	<i>Power Distribution Block</i>			<i>Standard Feed Thru/Splicer Block</i>			<i>Standard Feed Thru/Splicer Block</i>		
Approvals (See Page 12-6)									
Current Rating (per pole)	760A			115A			115A		
Voltage Rating (per pole)	600V AC/DC			600V AC/DC			600V AC/DC		
Number of Poles	3 Pole			1 Pole			3 Pole		
Insulating Material Max. Temperature Rating	150°C			150°C			150°C		
Flammability Rating	94V-O			94V-O			94V-O		
Terminal Blocks	Catalog No.	Pcs./ Pkg.	*	Catalog No.	Pcs./ Pkg.	*	Catalog No.	Pcs./ Pkg.	*
Terminal Block:	1492-PD3287	1		1492-50Y	1		1492-50X	1	
Block Characteristics	Line	Load		Line	Load		Line	Load	
Openings Per Pole	2	8		1	1		1	1	
Wire Range (AWG)	500kcmil-#4 AWG	#2/0-14		#2-14	#2-14		#2-14	#2-14	
Rated Cross Section (mm ²)	240-25	70-2.5		35-2.5	35-2.5		35-2.5	35-2.5	
Tightening Torque Range (also on block by specific wire size)	375 lb.-in. (42.4 Nm)	35-120 lb.-in. (4.0-13.5 Nm)		35-50 lb.-in. (4.0-5.6 Nm)	35-50 lb.-in. (4.0-5.6 Nm)		35-50 lb.-in. (4.0-5.6 Nm)	35-50 lb.-in. (4.0-5.6 Nm)	
Marking Strip	Single White Strip			Single White Strip			Single White Strip		
Connector Material	Aluminum			Aluminum			Aluminum		
Dimensions	See Page 12-88			See Page 12-88			See Page 12-88		

	1492-100Y			1492-100X			1492-BE		
									
	Line			Line			Line		
									
	Load			Load			Load		
									
Specifications	Standard Feed Thru/Splicer Block			Standard Feed Thru/Splicer Block			Standard Feed Thru/Splicer Block		
Approvals (See Page 12-6)	UL/CSA			UL/CSA			UL/CSA		
Current Rating (per pole)	175A			175A			255A		
Voltage Rating (per pole)	600V AC/DC			600V AC/DC			600V AC/DC		
Number of Poles	1 Pole			3 Pole			1 Pole		
Insulating Material Max. Temperature Rating	150°C			150°C			150°C		
Flammability Rating	94V-O			94V-O			94V-O		
Terminal Blocks	Catalog No.	Pcs./ Pkg.	*	Catalog No.	Pcs./ Pkg.	*	Catalog No.	Pcs./ Pkg.	*
Terminal Block:	1492-100Y	1		1492-100X	1		1492-BE	1	
Block Characteristics	Line	Load		Line	Load		Line	Load	
Openings Per Pole	1	1		1	1		1	1	
Wire Range (AWG)	#2/0-14	#2/0-14		#2/0-14	#2/0-14		250kcmil- #6 AWG	250kcmil- #6 AWG	
Rated Cross Section (mm ²)	70-2.5	70-2.5		70-2.5	70-2.5		120-16	120-16	
Tightening Torque Range (also on block by specific wire size)	35-120 lb.-in. (4.0-13.5 Nm)	35-120 lb.-in. (4.0-13.5 Nm)		35-120 lb.-in. (4.0-13.5 Nm)	35-120 lb.-in. (4.0-13.5 Nm)		275 lb.-in. (31.1 Nm)	275 lb.-in. (31.1 Nm)	
Marking Strip	Single White Strip			Single White Strip			Single White Strip		
Connector Material	Aluminum			Aluminum			Aluminum		
Dimensions	See Page 12-88			See Page 12-88			See Page 12-88		

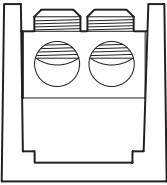
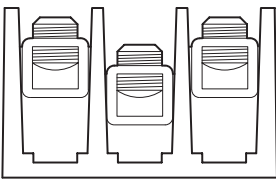
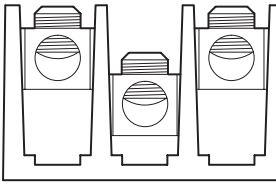
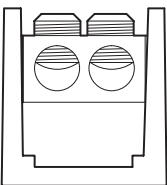
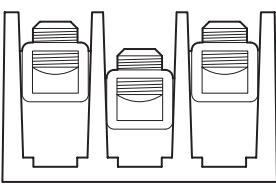
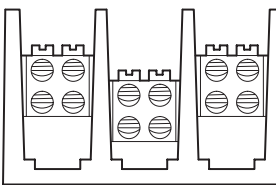

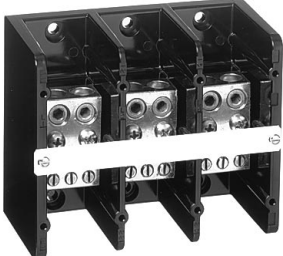

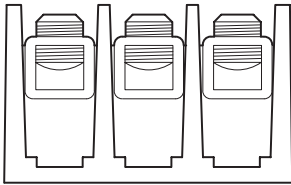
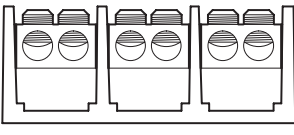
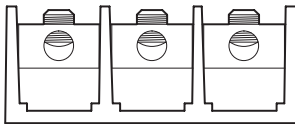
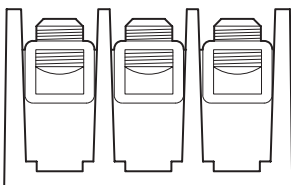
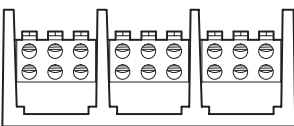
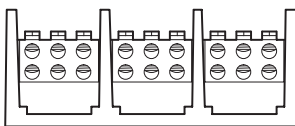
	1492-PD3113			1492-BF			1492-PD3226		
									
	Line			Line			Line		
									
	Load			Load			Load		
									
Specifications	<i>Standard Feed Thru/Splicer Block</i>			<i>Standard Feed Thru/Splicer Block</i>			<i>Standard Feed Thru/Splicer Block</i>		
Approvals (See Page 12-6)	UL/CSA			UL/CSA			UL/CSA		
Current Rating (per pole)	310A			420A			620A		
Voltage Rating (per pole)	600V AC/DC			600V AC/DC			600V AC/DC		
Number of Poles	3 Pole			1 Pole			3 Pole		
Insulating Material Max. Temperature Rating	150°C			150°C			150°C		
Flammability Rating	94V-O			94V-O			94V-O		
Terminal Blocks	Catalog No.	Pcs./ Pkg.	*	Catalog No.	Pcs./ Pkg.	*	Catalog No.	Pcs./ Pkg.	*
Terminal Block:	1492-PD3113	1		1492-BF	1		1492-PD3226	1	
Block Characteristics	Line	Load		Line	Load		Line	Load	
Openings Per Pole	1	1		1	1		2	2	
Wire Range (AWG)	350kcmil- #6 AWG	350kcmil- #6 AWG		600kcmil- #4 AWG	600kcmil- #4 AWG		350kcmil- #6 AWG	350kcmil- #6 AWG	
Rated Cross Section (mm ²)	185-16	185-16		300-25	300-25		185-16	185-16	
Tightening Torque Range (also on block by specific wire size)	275 lb.-in. (31.1 Nm)	275 lb.-in. (31.1 Nm)		500 lb.-in. (56.4 Nm)	500 lb.-in. (56.4 Nm)		275 lb.-in. (31.1 Nm)	275 lb.-in. (31.1 Nm)	
Marking Strip	Single White Strip			Single White Strip			Single White Strip		
Connector Material	Aluminum			Aluminum			Aluminum		
Dimensions	See Page 12-88			See Page 12-88			See Page 12-88		

	1492-BG			1492-PD3C111			1492-PD3C141		
									
	Line			Line			Line		
									
	Load			Load			Load		
									
Specifications	Standard Feed Thru/Splicer Block			Copper Connector Block			Copper Connector Block		
Approvals (See Page 12-6)	UL/CSA			UL/CSA			UL/CSA		
Current Rating (per pole)	760A			150A			175A		
Voltage Rating (per pole)	600V AC/DC			600V AC/DC			600V AC/DC		
Number of Poles	1 Pole			3 Pole			3 Pole		
Insulating Material Max. Temperature Rating	150°C			150°C			150°C		
Flammability Rating	94V-O			94V-O			94V-O		
Terminal Blocks	Catalog No.	Pcs./ Pkg.	*	Catalog No.	Pcs./ Pkg.	*	Catalog No.	Pcs./ Pkg.	*
Terminal Block:	1492-BG	1		1492-PD3C111	1		1492-PD3C141	1	
Block Characteristics	Line	Load		Line	Load		Line	Load	
Openings Per Pole	2	2		1	1		1	4	
Wire Range (AWG)	500kcmil- #4 AWG	500kcmil- #4 AWG		#1/0-18	#1/0-18		#2/0-14	#4-14	
Rated Cross Section (mm ²)	240-25	240-25		50-0.75	50-0.75		70-2.5	25-2.5	
Tightening Torque Range (also on block by specific wire size)	375 lb.-in. (42.4 Nm)	375 lb.-in. (42.4 Nm)		35-50 lb.-in. (4.0-5.6 Nm)	35-50 lb.-in. (4.0-5.6 Nm)		35-120 lb.-in. (4.0-13.5 Nm)	35-50 lb.-in. (4.0-5.6 Nm)	
Marking Strip	Single White Strip			Single White Strip			Single White Strip		
Connector Material	Aluminum			Copper			Copper		
Dimensions	See Page 12-88			See Page 12-88			See Page 12-88		

	1492-PD3C112			1492-PD3C263			1492-PD3C163		
									
	Line			Line			Line		
									
	Load			Load			Load		
									
Specifications	<i>Copper Connector Block</i>			<i>Copper Connector Block</i>			<i>Copper Connector Block</i>		
Approvals (See Page 12-6)	UL/CSA			UL/CSA			UL/CSA		
Current Rating (per pole)	255A			350A			380A		
Voltage Rating (per pole)	600V AC/DC			600V AC/DC			600V AC/DC		
Number of Poles	3 Pole			3 Pole			3 Pole		
Insulating Material Max. Temperature Rating	150°C			150°C			150°C		
Flammability Rating	94V-O			94V-O			94V-O		
Terminal Blocks	Catalog No.	Pcs./ Pkg.	*	Catalog No.	Pcs./ Pkg.	*	Catalog No.	Pcs./ Pkg.	*
Terminal Block:	1492-PD3C112	1		1492-PD3C263	1		1492-PD3C163	1	
Block Characteristics	Line	Load		Line	Load		Line	Load	
Openings Per Pole	1	1		2	6		1	6	
Wire Range (AWG)	250kcmil- #6 AWG	250kcmil- #6 AWG		#2/0-14	#4-14		500kcmil- #4 AWG	#2-14	
Rated Cross Section (mm ²)	120-16	120-16		70-2.5	25-2.5		240-25	35-2.5	
Tightening Torque Range (also on block by specific wire size)	375 lb.-in. (42.4 Nm)	375 lb.-in. (42.4 Nm)		35-120 lb.-in. (4.0-13.5 Nm)	35-45 lb.-in. (4.0-5.1 Nm)		375 lb.-in. (42.4 Nm)	35-50 lb.-in. (4.0-5.6 Nm)	
Marking Strip	Single White Strip			Single White Strip			Single White Strip		
Connector Material	Copper			Copper			Copper		
Dimensions	See Page 12-88			See Page 12-88			See Page 12-88		

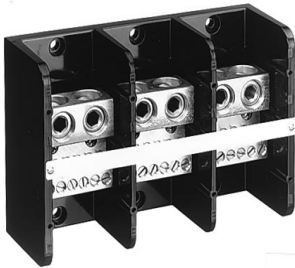
1492-PD3C2127

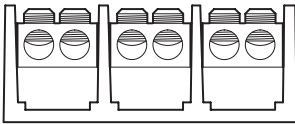
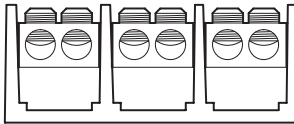
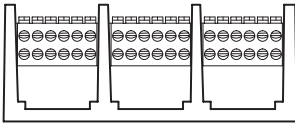
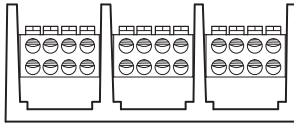
1492-PD3C287

						
	Line			Line		
						
	Load			Load		
						
Specifications	<i>Copper Connector Block</i>			<i>Copper Connector Block</i>		
Approvals (See Page 12-6)						
Current Rating (per pole)	760A			760A		
Voltage Rating (per pole)	600V AC/DC			600V AC/DC		
Number of Poles	3 Pole			3 Pole		
Insulating Material Max. Temperature Rating	150°C			150°C		
Flammability Rating	94V-O			94V-O		
Terminal Blocks	Catalog No.	Pcs./ Pkg.	*	Catalog No.	Pcs./ Pkg.	*
Terminal Block:	1492-PD3C2127	1		1492-PD3C287	1	
Block Characteristics	Line	Load		Line	Load	
Openings Per Pole	2	12		2	8	
Wire Range (AWG)	500kcmil-#4 AWG	#2-14		500kcmil-#4 AWG	#2/0-14	
Rated Cross Section (mm ²)	240-25	35-2.5		240-25	70-2.5	
Tightening Torque Range (also on block by specific wire size)	375 lb.-in. (42.4 Nm)	35-50 lb.-in. (4.0-5.6 Nm)		375 lb.-in. (42.4 Nm)	35-120 lb.-in. (4.0-13.5 Nm)	
Marking Strip	Single White Strip			Single White Strip		
Connector Material	Copper			Copper		
Dimensions	See Page 12-88			See Page 12-88		

Approximate Dimensions

All dimensions are in inches (millimeters). Dimensions are not intended to be used for manufacturing purposes.

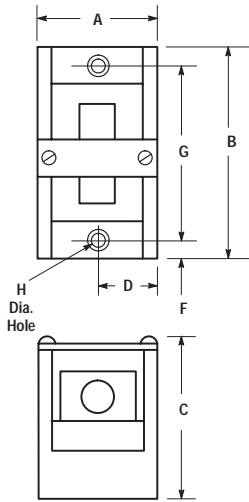

FIGURE 1

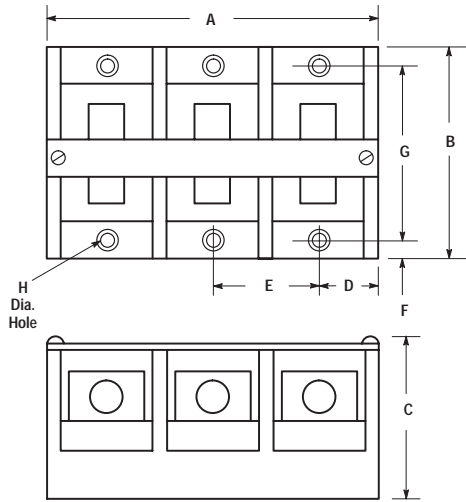

FIGURE 2

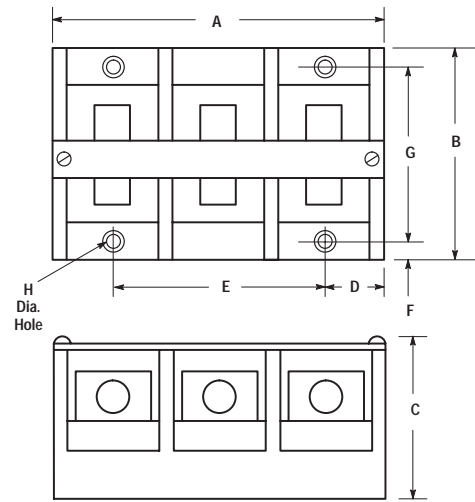

FIGURE 3

Catalog Number	Figure	A	B	C	D	E	F	G	H
1492-PDM3111	3●	2.03 (51.56)	2.29 (58.17)	1.62 (41.15)	0.38 (9.68)	1.27 (32.26)	0.19 (4.83)	1.93 (49.02)	0.201 (5.11)
1492-PDM3141	3●	2.03 (51.56)	2.29 (58.17)	1.62 (41.15)	0.38 (9.68)	1.27 (32.26)	0.19 (4.83)	1.93 (49.02)	0.201 (5.11)
1492-50Y	1	1.13 (28.7)	2.88 (73.15)	1.88 (47.8)	0.56 (14.22)	—	0.31 (7.87)	2.25 (57.15)	0.205 (5.21)
1492-100Y	1	1.13 (28.7)	2.88 (73.15)	1.88 (47.8)	0.56 (14.22)	—	0.31 (7.87)	2.25 (57.15)	0.205 (5.21)
1492-50X	3	2.75 (69.85)	2.88 (73.15)	1.88 (47.8)	0.56 (14.22)	1.62 (41.2)	0.31 (7.87)	2.25 (57.15)	0.205 (5.21)
1492-100X	3	2.75 (69.85)	2.88 (73.15)	1.88 (47.8)	0.56 (14.22)	1.62 (41.2)	0.31 (7.87)	2.25 (57.15)	0.205 (5.21)
1492-50XF	3	2.75 (69.85)	2.88 (73.15)	1.88 (47.8)	0.56 (14.22)	1.62 (41.2)	0.31 (7.87)	2.25 (57.15)	0.205 (5.21)
1492-50YF	1	1.13 (28.7)	2.88 (73.15)	1.88 (47.8)	0.56 (14.22)	—	0.31 (7.87)	2.25 (57.15)	0.205 (5.21)
1492-100XF	3	2.75 (69.85)	2.88 (73.15)	1.88 (47.8)	0.56 (14.22)	1.62 (41.2)	0.31 (7.87)	2.25 (57.15)	0.205 (5.21)
1492-100YF	1	1.13 (28.7)	2.88 (73.15)	1.88 (47.8)	0.56 (14.22)	—	0.31 (7.87)	2.25 (57.15)	0.205 (5.21)
1492-PD3C111	3	2.75 (69.85)	2.88 (73.15)	1.88 (47.8)	0.56 (14.22)	1.62 (41.2)	0.31 (7.87)	2.25 (57.15)	0.205 (5.21)
1492-PD3C141	3	2.75 (69.85)	2.88 (73.15)	1.88 (47.8)	0.56 (14.22)	1.62 (41.2)	0.31 (7.87)	2.25 (57.15)	0.205 (5.21)
1492-PD3141	3	2.75 (69.85)	2.88 (73.15)	1.88 (47.8)	0.56 (14.22)	1.62 (41.2)	0.31 (7.87)	2.25 (57.15)	0.205 (5.21)
1492-BE	1	1.94 (49.28)	4 (101.6)	2.72 (69.1)	0.97 (24.64)	—	0.31 (7.87)	3.38 (85.85)	0.203 (5.16)
1492-PD3C112	2	5 (127)	4 (101.6)	2.72 (69.1)	0.97 (24.64)	1.53 (38.86)	0.31 (7.87)	3.38 (85.85)	0.203 (5.16)
1492-PD3113	2	5 (127)	4 (101.6)	2.72 (69.1)	0.97 (24.64)	1.53 (38.86)	0.31 (7.87)	3.38 (85.85)	0.203 (5.16)
1492-PD3263	2	5 (127)	4 (101.6)	2.72 (69.1)	0.97 (24.64)	1.53 (38.86)	0.31 (7.87)	3.38 (85.85)	0.203 (5.16)
1492-PD3163	2	5 (127)	4 (101.6)	2.72 (69.1)	0.97 (24.64)	1.53 (38.86)	0.31 (7.87)	3.38 (85.85)	0.203 (5.16)
1492-PD3C163	2	5 (127)	4 (101.6)	2.72 (69.1)	0.97 (24.64)	1.53 (38.86)	0.31 (7.87)	3.38 (85.85)	0.203 (5.16)
1492-PD3C263	2	5 (127)	4 (101.6)	2.72 (69.1)	0.97 (24.64)	1.53 (38.86)	0.31 (7.87)	3.38 (85.85)	0.203 (5.16)
1492-BF	1	2.28 (57.91)	4.75 (120.65)	2.92 (74.2)	1.12 (28.45)	—	0.31 (7.87)	4.13 (104.9)	0.203 (5.16)
1492-PD3183	2	6.04 (153.42)	4.75 (120.65)	2.92 (74.2)	1.12 (28.45)	1.88 (47.75)	0.31 (7.87)	4.13 (104.9)	0.203 (5.16)
1492-BG	1	3.17 (80.25)	5.50 (139.7)	3.23 (82.0)	1.58 (40.13)	—	0.38 (9.68)	4.75 (120.65)	0.265 (6.73)
1492-PD31123	2	8.54 (216.92)	5.50 (139.7)	3.23 (82.0)	1.58 (40.13)	2.69 (68.58)	0.38 (9.68)	4.75 (120.65)	0.265 (6.73)
1492-PD3287	2	8.54 (216.92)	5.50 (139.7)	3.23 (82.0)	1.58 (40.13)	2.69 (68.58)	0.38 (9.68)	4.75 (120.65)	0.265 (6.73)
1492-PD32127	2	8.54 (216.92)	5.50 (139.7)	3.23 (82.0)	1.58 (40.13)	2.69 (68.58)	0.38 (9.68)	4.75 (120.65)	0.265 (6.73)
1492-PD3226	2	8.54 (216.92)	5.50 (139.7)	3.23 (82.0)	1.58 (40.13)	2.69 (68.58)	0.38 (9.68)	4.75 (120.65)	0.265 (6.73)
1492-PD3C2127	2	8.54 (216.92)	5.50 (139.7)	3.23 (82.0)	1.58 (40.13)	2.69 (68.58)	0.38 (9.68)	4.75 (120.65)	0.265 (6.73)
1492-PD3C287	2	8.54 (216.92)	5.50 (139.7)	3.23 (82.0)	1.58 (40.13)	2.69 (68.58)	0.38 (9.68)	4.75 (120.65)	0.265 (6.73)

● No Marker Strip.

Allen-Bradley Thermal Magnetic Circuit Breakers are ideal for protecting control circuitry components from damage due to overcurrents and short circuits.

Circuit Breakers are UL Component Recognized and CSA Certified.

- UL File Number E65138, Guide Number QVNU2
- CSA File Number LR37712. Class 9091-01 (1492-CB)
- CSA File Numbers LR67768, LR16185. Class 9091-01 (1492-GH)
- VDE Specification 0642

Potential applications include:

- Solenoids
- Relay/contactor coils
- Transformers
- PLCs
- Computers
- Medical equipment
- Power supplies
- PLC I/O points

Three types of rail-mounted circuit breakers are available:

- Energy Limiting style CB
- High density style GH – single pole
- High density style GS – multi pole

1492-CB Energy Limiting Circuit Breakers:

1492-CB Circuit Breakers are offered in 1, 2, and 3 pole devices. These circuit breakers are DIN rail mountable and rated at 480/277V AC, 0.5 to 50A. They meet international standards for a wide range of applications.

Features include:

- IP2X Finger-Safe rating per IEC 947
- Six trip characteristics for a variety of applications
- Energy Limiting design limits damaging “let-through” energy during short circuits to a level well below that of conventional breakers
- Optional accessory modules for auxiliary contacts, signal contacts, relay trip modules and switched neutral modules
- 10,000A Interrupting Capacity

High-Density Style GH Circuit Breakers:

Mount on A-B rails or DIN rails, and are rated 250/125V AC, 65V DC – 0.2 to 15A.

- 1 pole with screw terminations
- Push button type actuation
- High density by design, each pole is only 0.49” thick.

GS Circuit Breakers:

Mount on A-B rails or DIN rails, and are rated 480/277V AC, 65V DC – 0.2 to 25A.

- Toggle style handle for easy opening/closing
- Optional auxiliary contact requires no additional space
- Available in 1, 2, and 3 pole designs

1492-FB Fuse Holders:

1492-FB Class CC Fuse Holders provide a DIN Rail mounted package for use in Class CC fuse applications like transformers and motors.

Features include:

- UL listed
- DIN #3 rail mounted
- Optional blown fuse indicator



Description

Bulletin 1492 Class CC Fuse Holders provide a safe and convenient means for the installation of Class CC fuses. The 1492-FB Fuse Holders are available in 1, 2, and 3 pole configurations and have an optional blown fuse indication light. The fuse holder is 30A rated at 600V and is UL listed. The FB Fuse Holder utilizes a self lifting box lug on the line and load side of the block, each capable of accepting a #6-#14 AWG copper wire.

Features

- The Patented handle design isolates the fuse from line power when the handle is opened for insertion or removal.
- Optional blown fuse indicators – allow for easy troubleshooting of electrical circuits.
- UL Listed

1492-FB1

1492-FB2

1492-FB3

Dimensions are not intended for manufacturing purposes.

Note: Height dimension is measured from top of rail to top of terminal block.

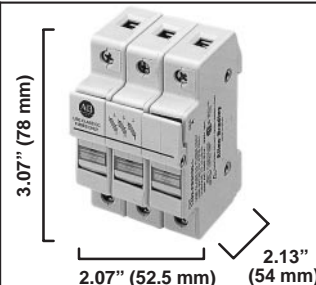
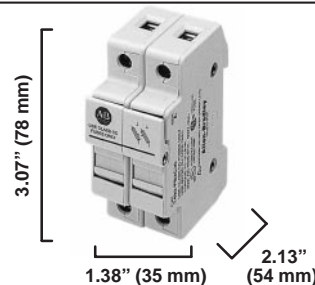
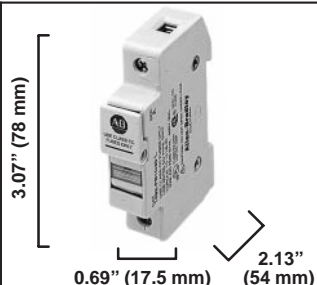

Specifications	1 pole fuse block			2 pole fuse block			3 pole fuse block		
Approvals (See Page 12-6)	UL	CSA		UL	CSA		UL	CSA	
Voltage Rating	600V AC/DC	600V AC/DC		600V AC/DC	600V AC/DC		600V AC/DC	600V AC/DC	
Maximum Current	30A	30A		30A	30A		30A	30A	
Wire Range (Rated Cross Section)	#14-#6 AWG	#14-#6 AWG		#14-#6 AWG	#14-#6 AWG		#14-#6 AWG	#14-#6 AWG	
Wire Strip Length	0.5" (12.7 mm)			0.5" (12.7 mm)			0.5" (12.7 mm)		
Recommended Tightening Torque	15 lb.-in. (1.7 Nm)			15 lb.-in. (1.7 Nm)			15 lb.-in. (1.7 Nm)		
Working Voltage (Indicating Circuit)	95-600V AC, 110-600V DC			95-600V AC, 110-600V DC			95-600V AC, 110-600V DC		
Leakage Current (Indicating Circuit)	0.8 mA max @ 600V			0.8 mA max @ 600V			0.8 mA max @ 600V		
Fuse Type	Use class CC fuse only ¹			Use class CC fuse only ¹			Use class CC fuse only ¹		
Insulation Temperature Range	-40°C to +105°C			-40°C to +105°C			-40°C to +105°C		
Fuse Holder	Catalog No.	Pcs./Pkg.	*	Catalog No.	Pcs./Pkg.	*	Catalog No.	Pcs./Pkg.	*
Without Blown Fuse Indicator	1492-FB1C30	6		1492-FB2C30	3		1492-FB3C30	2	
With Blown Fuse Indicator	1492-FB1C30-L	6		1492-FB2C30-L	3		1492-FB3C30-L	2	
Accessories	Catalog No.	Pcs./Pkg.	*	Catalog No.	Pcs./Pkg.	*	Catalog No.	Pcs./Pkg.	*
Mounting Rails: (Details Page 12-143) 1 M Symmetrical DIN (Steel)	199-DR1	10		199-DR1	10		199-DR1	10	
1 M Symmetrical DIN (Aluminum)	1492-DR5	10		1492-DR5	10		1492-DR5	10	
1 M Hi-Rise Sym. DIN (Aluminum)	1492-DR6	2		1492-DR6	2		1492-DR6	2	
1 M Angled Hi-Rise Sym. DIN (Steel)	1492-DR7	2		1492-DR7	2		1492-DR7	2	
End Anchors: (Details Page 12-146) DIN Rail — Normal Duty	1492-EA35	50		1492-EA35	50		1492-EA35	50	
DIN Rail — Heavy Duty	1492-EAH35	10		1492-EAH35	10		1492-EAH35	10	

¹ Gould ATQR 1-1/4, I=0.42A max.
 Gould ATQR 1-4/10, I=0.47A max.

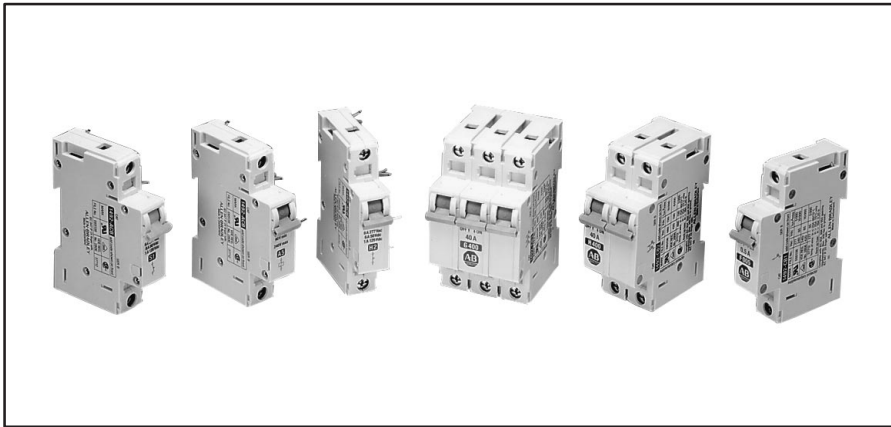

Description

Bulletin 1492 “Energy Limiting” circuit breakers are thermal magnetic type **supplementary** overcurrent protective devices. Bulletin 1492–CB circuit breakers are available in one, two and three pole units rated from 0.5 to 50 amps. AC units are rated 65V as standard. Two and three pole devices are connected internally and at the handle for simultaneous operation.

Wire termination is achieved by a clamping style, self-lifting box lug on all Bulletin 1492–CB units. Both line and load side termination points will accept #16–6 AWG (1.5–16mm²) copper wires.

Features

- “Energy Limiting” Design — protects downstream components better than conventional breakers during short circuits
- Field mountable options for selective applications
- True IP2X “Finger-Safe” design (top and sides)
- International approvals — meets NEMA and IEC standards for worldwide acceptance
- Ratings to 480V AC and 10,000A Interrupt Capacity
- AC and DC voltage ratings — in one convenient device
- A “positively trip free” mechanism
- Time delay (H characteristic) for high inrush currents during inductive start-ups such as transformers and power supplies
- Superior shock and vibration resistance capabilities — helps to prevent nuisance tripping

Energy Limitations

1492–CB vs. Conventional Breakers

The 1492–CB line features the unique ability to achieve short circuit interruptions far more effectively than conventional breakers.

In *conventional circuit breakers*, short circuit interruption time required is approximately one or two half cycles of an AC sine wave. When the contacts open, the resulting arc continues to burn until the current level passes through zero. The arc may re-ignite because of the insufficient width of the contact gap. The current that flows until the arc is extinguished produces a heating effect proportional to the I²t value (*let-through-energy*) of the fault current.

Short Circuit Interruption Diagrams

Short Circuit Interruption 10 kA – 120 Volts AC

Instant of initiation: 15° after voltage zero.

CONVENTIONAL BREAKERS

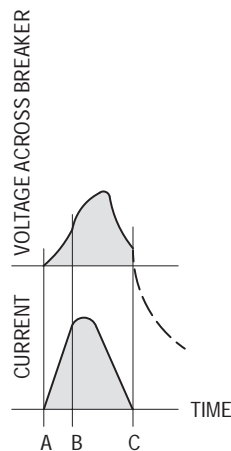

A = Instant when the short is initiated
 B = Instant when the contacts open and the arc is initiated
 C = Instant when the arc extinguishes and the current ceases to flow

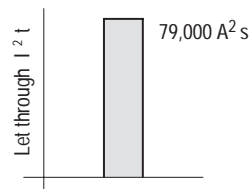

The 1492–CB “Energy Limiting” circuit breaker is designed to substantially reduce the amount of *let-through-current* and the resulting *let-through-energy* that can damage protected components. The 1492–CB has the ability to interrupt short circuit current within the first half cycle of the fault.

The Benefits of Limiting Let-Through-Energy

Limiting Let-Through-Energy will protect against the harmful effects of overcurrent and is focused primarily on avoiding the following:

- Excessive Heat
- Mechanical Damage

Both of these factors are proportional to the square of the current. Thermal energy is proportional to the square of the RMS value and magnetic forces are proportional to the square of the peak value. The most effective way to provide protection is to substantially limit *let-through-energy*. This provides the following advantages:

- Far less damage at the location of the short circuit.
- Fast electric separation of a faulty unit from the system, especially power supplies connected in parallel that are switched off when the voltage of the power bus drops below a certain level.

ALLEN-BRADLEY 1492–CB

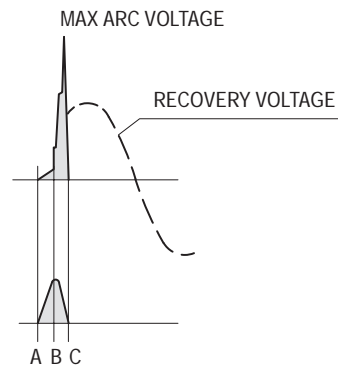

The Benefits of Limiting Let-Through-Energy (cont'd)

- Far less wear on the circuit breaker itself. This means more safe interruptions.
- Better protection of all components in the short circuit path.
- Far wider range of selective action when used with an upstream protective device. (No nuisance shut downs from feeder line interruptions, causing a blackout in all connected branches.)

Applications

Bulletin 1492-CB “Energy Limiting” circuit breakers have a wide range of trip characteristics for a wide range of applications.

- “F” trip characteristic (3–5 x I_n)¹ for low fault tolerant loads, such as PLC outputs, solid state control equipment, and also for selective action with an upstream fault device
- “G” trip characteristic (6–10 x I_n)¹ for standard duty loads, such as relay coils, control circuitry, and test equipment
- “H” trip characteristic (12–20 x I_n)¹ for high inrush loads, such as power supplies, heaters, and transformer primaries.

A type “F” has a fault level interruption approximately half that of type “G”. The type “H” has a fault level interruption approximately twice that of type “G”.

Accessories

Note: Maximum of 2 accessories per device.

Auxiliary Contacts

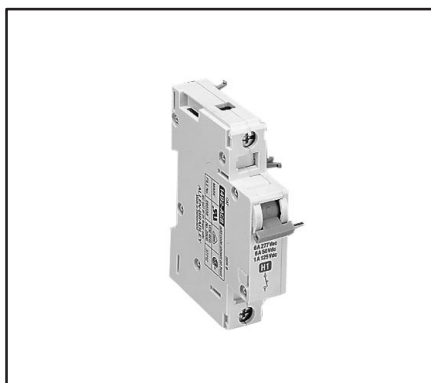

Auxiliary Contacts:

Refer to Specifications on page 12-96 for ratings. Each auxiliary contact module contains one (1) contact, either Normally Open or Normally Closed. Actuation of the contact is determined by the handle position of the adjacent poles.

Signal Contacts

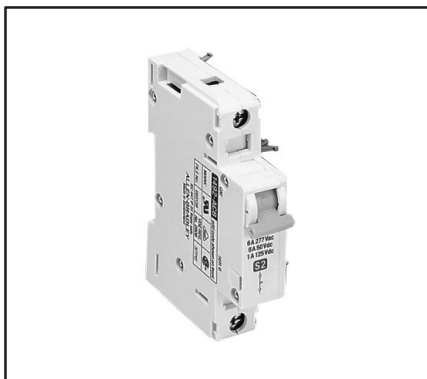

Signal Contacts:

Refer to Specifications on page 12-96 for ratings. Each contact module contains one contact that will be linked internally with the adjacent poles, but not through the handle. Contacts are actuated by a fault condition on the protected poles, not by the manual operation of them.

Note: The difference between an Auxiliary contact and a Signal contact is the protected poles adjacent to the Signal contact may be manually shut off without affecting the status of the signal contact, whereas the auxiliary contact is activated either by manual (possibly to service a panel) or automatic operation (fault) of the protected poles. Manual operation of the protected poles does not alter the contact state of the Signal contact (which may be connected to an alarm circuit for fault indication only).

Relay Trip (Shunt-Trip)

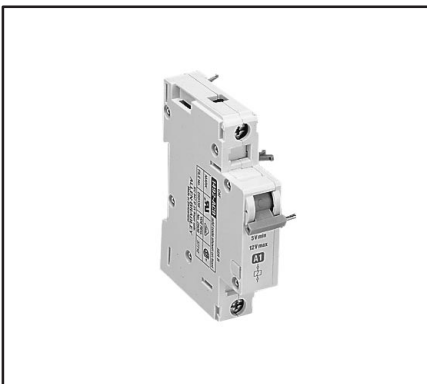

Relay Trip (Shunt-Trip):

Refer to the table at the top of the next column for ratings. The Relay trip module can be used to trip the adjacent current carrying poles from a remote location by applying a voltage (pick-up voltage) to the Relay trip terminals. Contacts operate between 8 and 16 milliseconds after the pick-up voltage has been applied.

Type	Pick-Up Voltage Range	Impedance
A1	5–15 Volts AC/DC	1.1 Ohms
A2	10–24 Volts AC/DC	4.7 Ohms
A3	20–48 Volts AC/DC	16 Ohms
A4	40–110 Volts AC/DC	63 Ohms
A5	90–240 Volts AC/DC	395 Ohms

Switched Neutral Module (not field mountable)

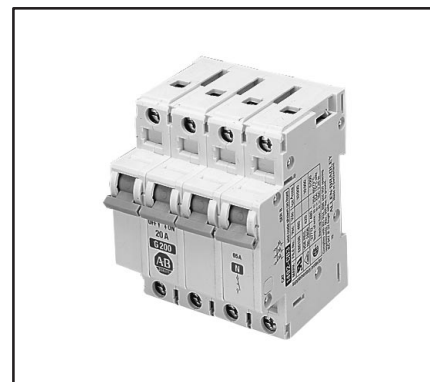

Switched Neutral Module (not field mountable):

Refer to Specifications on page 12-96 for ratings. This module is used to open the neutral line of the circuit as a result of the condition of the protected poles. It is used as a safety measure (required by some standards) for the protection of networks with a grounded neutral system. The switched neutral pole opens after and closes before the adjacent protected pole (i.e. early make, late break). Automatic actuation is a result of the adjacent pole trip mechanism and manual actuation is by the linked handles.

¹ I_n = Rated Current

Bulletin 1492
Circuit Protection
Circuit Breakers

How to Order 1492-CB

The following information must be known to select the proper circuit breaker:

- What is the full load amperage that will be available in the system?
- Is it a 1, 2, or 3 phase system?
- What are the start-up or inrush properties of the load?

- Will the system require additional "shaping" options? Auxiliary contacts, signal contacts, etc.

After defining these few parameters, the selection can be done by following the chart below. All options are field mountable except the Neutral switch, which comes installed from the factory.

Selection Information

You can order a basic one, two, or three pole circuit breaker from the following tables and add an accessory module to meet your specific application requirements.

1492 – CB 3 G 200 – N¹⁴

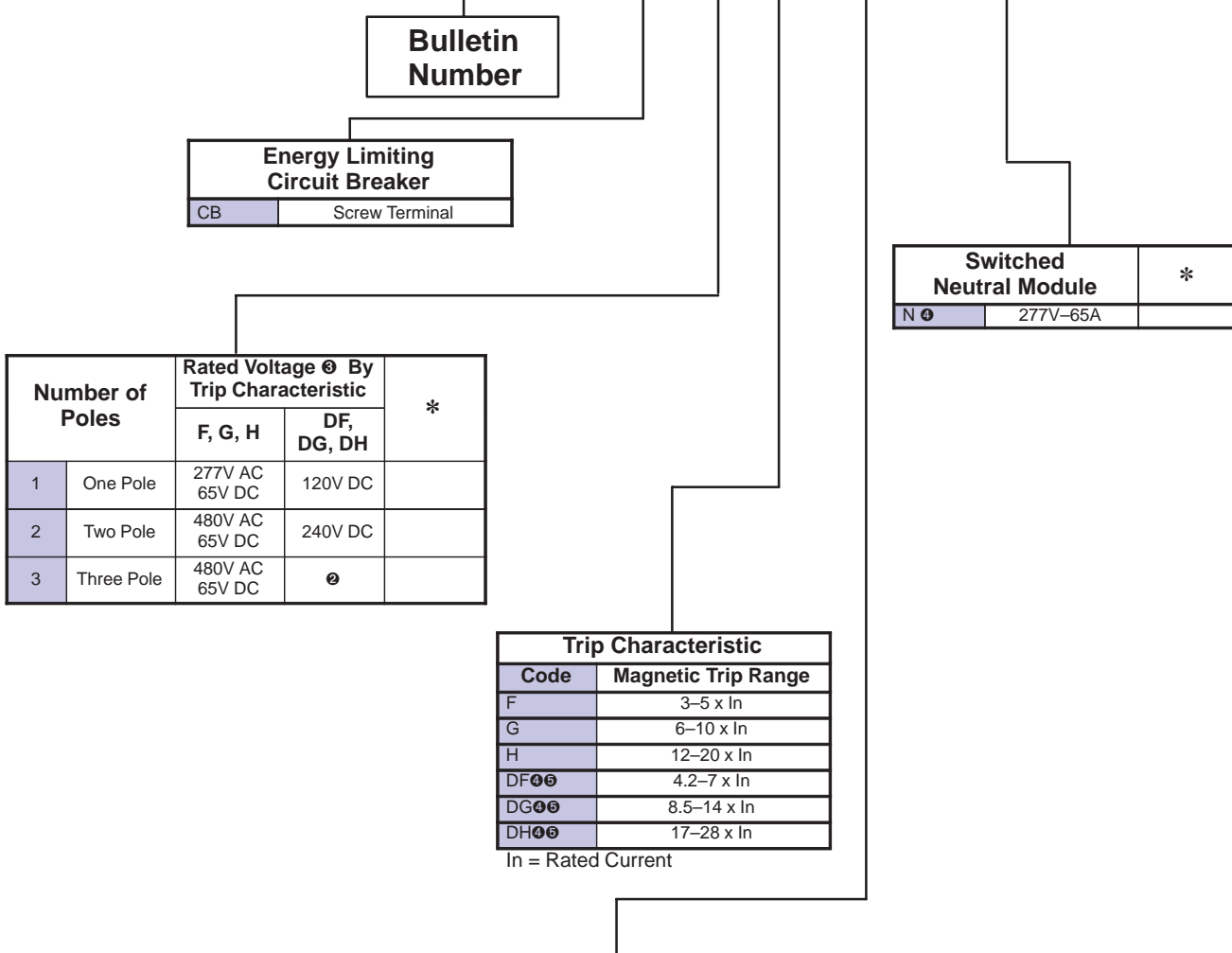

Number of Poles		Rated Voltage Ⓢ By Trip Characteristic		*
		F, G, H	DF, DG, DH	
1	One Pole	277V AC 65V DC	120V DC	
2	Two Pole	480V AC 65V DC	240V DC	
3	Three Pole	480V AC 65V DC	Ⓢ	

Trip Characteristic	
Code	Magnetic Trip Range
F	3–5 x I _n
G	6–10 x I _n
H	12–20 x I _n
DFⓈ	4.2–7 x I _n
DGⓈ	8.5–14 x I _n
DHⓈ	17–28 x I _n

I_n = Rated Current

Trip Char.	Current Rating Code (Standard Trip Characteristic is Type G)																		
	005	010	020	030	040	050	060	070	100	120	150Ⓢ	160Ⓢ	200Ⓢ	250Ⓢ	300Ⓢ	320Ⓢ	400Ⓢ	500Ⓢ	
F																			
G																			
H																			
DFⓈ																			
DGⓈ																			
DHⓈ																			
Amp Rating	0.5	1	2	3	4	5	6	7	10	12	15	16	20	25	30	32	40	50	

Ⓢ This alphanumeric character is for the optional neutral module. Ⓢ Consult factory. Ⓢ Rated volts are UL Recognized.
 Ⓢ Minimum order of 10 breakers required for any configuration of the items with this footnote.
 Ⓢ **Attention:** Do not use these DC versions in AC networks. Polarity markings must be observed with the DC versions.

Accessories Used with All 1492–CB Circuit Breakers

Accessory	Catalog No.	Pcs./Pkg.	*
Mounting Rails: (Details Page 12-143) 1 Meter Symmetrical DIN	199–DR1	10	
1 M Symmetrical DIN (Alumin.)	1492–DR5	10	
1 M Hi-Rise Symmetrical DIN	1492–DR6	2	
1 M Angled Hi-Rise Symmetrical DIN	1492–DR7	2	
End Anchor	1492–EAH35	50	
Group Marking	1492–GM35	10	
Marking Systems (See Page 12-155)	1492–SMN83	5	

Field Mounted Accessories Used with 1492–CB Circuit Breakers

Accessory	Catalog No.	Pcs./Pkg.	*
Auxiliary Contacts: Normally Open ❶	1492–ACBH1	1	
Normally Closed ❷	1492–ACBH2	1	
Signal Contacts: Normally Open ❶	1492–ACBS1	1	
Normally Closed ❷	1492–ACBS2	1	
Relay Trip Module: 5–12V AC/DC	1492–ACBA1	1	
10–24V AC/DC	1492–ACBA2	1	
20–48V AC/DC	1492–ACBA3	1	
40–110V AC/DC	1492–ACBA4	1	
90–240V AC/DC	1492–ACBA5	1	
Connecting Clip	1492–ACBCC1	8	
Opening Seal	1492–ACBHS1	10	
Commoning Links 1 Meter – 1 Pole (56 devices/meter) 30 Amps	1492–ACBCL1	1	
1 Meter – 2 Pole (29 devices/meter) 40 Amps	1492–ACBCL2	1	
1 Meter – 3 Pole (19 devices/meter) 40 Amps	1492–ACBCL3	1	
Front Panel Mounting Brackets: 1 Pole	1492–N711	5	
2 Pole	1492–N712	5	
3 Pole	1492–N713	5	
4 Pole	1492–N714	5	
5 Pole	1492–N715	5	

❶ Normally Open — Contact assumes the same position as the protected poles. When breaker is off, contact is open.

❷ Normally Closed — Contact assumes the opposite position of the protected poles. When breaker is off, contact is closed.

Bulletin 1492
Circuit Protection
Circuit Breakers

1492-CB

Specifications

Catalog Number	1492-CB1			1492-CB2					1492-CB3				
Description	1 Pole			2 Pole					3 Pole				
Approvals	UL, CSA, VDE			UL, CSA, VDE					UL, CSA, VDE				
Short Circuit Capacity in DC Circuits	1492-CB1D 10,000A at 120V DC			1492-CB2D 10,000A at 240V DC					1492-CB3D 10,000A at 360V DC				
Maximum Voltage Ratings	480V AC, 65 Volts DC Max. DC Version up to 120 Volts per Pole. A Three Pole Breaker will operate to 360V DC.												
Internal Impedance Type G Trip Characteristic	Amp. Rating (Amps.)	0.5	1	2	4	6	10	16	20	25	32	40	50
	Impedance (Ohms)	5.6	1.33	.33	.09	.04	.02	.008	.005	.005	.003	.003	.025
Dielectric Strength	1960V AC												
Shock	25G Half Sine Wave for 11 Milliseconds (Three Axes)												
Vibration	10-500 Hz for 1 Hour Amplitude: 10-57 Hz; .030 inches peak to peak 57-500 Hz; 5G peak												
Maximum Interrupting Capacity	Up to 10,000 Amps. See page 12-97 for details on specific devices.												
Operating Temperature Range	-20°C to +60°C (-4°F to +140°F)												
Shipment and Short Term Temperature Limits	-40°C to +85°C (-40°F to +185°F)												
Housing Material	Melamine — Phenolic												
Wire Size	#16-6 AWG (1.5-16 mm ²)												
Recommended Wire Strip Length	0.51" (13 mm)												
Electromechanical Life	Up to 6A	50,000 Cycles											
	7 to 16A	30,000 Cycles											
	20 to 32A	20,000 Cycles											
	40 to 50A	12,000 Cycles											
Auxiliary Contact Ratings	277V AC, 6A 125V DC, 1A 50V DC, 6A												
Signal Contact Ratings	277V AC, 6A 125V DC, 1A 50V DC, 6A												
Switched Neutral Rating	277V AC, 65A												

- ① Performance Data — See Page Important-2.
- ② Circuit breakers also meet the requirements of AS, BS and SEV.

Approximate Dimensions

Dimensions shown in inches (millimeters). Dimensions are not intended to be used for manufacturing purposes.

No. of Poles	1	2	3	4	5
Width (inches)	0.7	1.4	2.1	2.8	3.5
Width (millimeters)	17.5 +0.05 -0	35 +1 -0	52.5 +1.5 -0	70 +2 -0	87.5 +2.5 -0

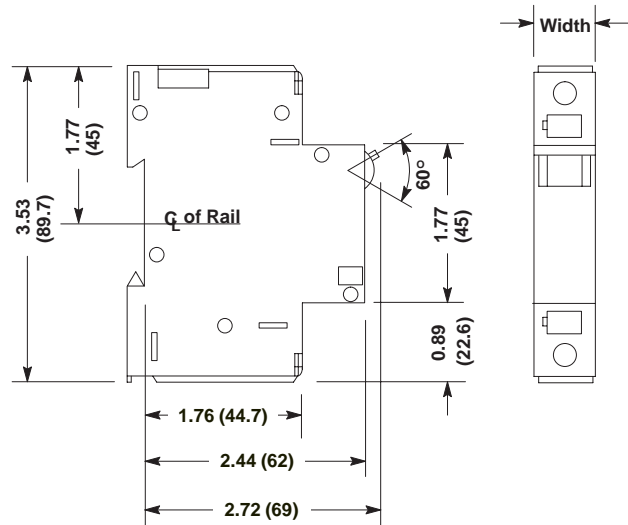

Electrical Characteristics and Approvals

PROTECTED POLES — AC/DC VERSIONS (F, G, H)							
Agency/Standard	Terminal Block Style	Poles	Tripping Characteristics	Rated Currents	VAC	VDC	Interrupting Capacity
UL 1077	CB	1	F, G, H	0.5-50A	277	65	5000/2000 A
UL 1077	CB	1	F, G,	0.5-40A	240	65	10000/2000 A
UL 1077	CB	1	H	0.5-40A	277	65	5000/2000 A
UL 1077	CB	2	F, G, H	0.5-50A	480	65	5000/2000 A
UL 1077	CB	2	F, G,	0.5-40A	480	65	10000/2000 A
UL 1077	CB	2	H	0.5-40A	480	65	5000/2000 A
UL 1077	CB	3	F, G, H	0.5-50A	480	65	5000/2000 A
UL 1077	CB	3	F, G	0.5-40A	480	65	10000/2000 A
UL 1077	CB	3	H	0.5-40A	480	65	5000/2000 A
VDE REG. NO.2806	CB	1	F, G	0.5-25A	240/420	—	10000A
VDE REG. NO.2806	CB	1	H	0.5-40A	240/420	—	6000A
VDE REG. NO.2806	CB	1	F, G	30-40A	240/420	—	6000A
VDE REG. NO.2806	CB	2	F, G	0.5-25A	420	—	10000A
VDE REG. NO.2806	CB	2	H	0.5-40A	420	—	6000A
VDE REG. NO.2806	CB	2	F, G	30-40A	420	—	6000A
VDE REG. NO.2806	CB	3	F, G	0.5-25A	420	—	10000A
VDE REG. NO.2806	CB	3	H	0.5-40A	420	—	6000A
VDE REG. NO.2806	CB	3	F, G	30-40A	420	—	6000A
CSA 22.2 NO.14	CB	1	F, G, H	0.5-50A	277	65	5000/2000 A
CSA 22.2 NO.14	CB	2	F, G	0.5-40A	480	65	10000/2000 A
CSA 22.2 NO.14	CB	2	F, G, H	45-50A	480	65	5000/2000 A
CSA 22.2 NO.14	CB	2	H	0.5-40A	480	65	5000/2000 A
CSA 22.2 NO.14	CB	3	F, G	0.5-40A	480	65	10000/2000 A
CSA 22.2 NO.14	CB	3	F, G, H	45-50A	480	65	5000/2000 A
CSA 22.2 NO.14	CB	3	H	0.5-40A	480	65	5000/2000 A

On standard AC/DC versions (F, G, H) line and load connections may be reversed.

1492–GH Circuit Breakers
High Density Circuit Breakers

1492–GH . . .

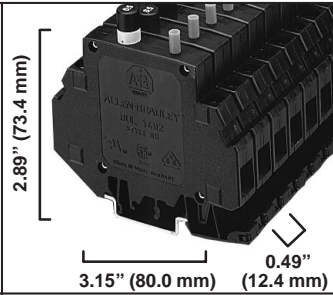

Specifications		<i>High density one pole circuit breaker, thermal magnetic, mounts on A-B rail and DIN rails.</i>		
Approvals (See Page 12-6)		CSA/VDE		
Maximum Voltage Rating		250V AC (0.2-7A), 125V AC (10-15A), 65V DC		
Maximum Interrupting Capacity (that allows continued use)		200A (not to exceed 100 times rated current)		
Wire Range (Rated Cross Section)		#22-#10 AWG (0.5-6 mm ²)		
Wire Strip Length		0.44" (11.2 mm)		
Recommended Screw Tightening Torque		10-12 lb.-in. (1.13-1.4 Nm)		
Insulation Temperature Range		-40°C to +105°C		
Terminal Blocks		Catalog No.	Pcs./ Pkg.	*
Amperage Rating:	0.2A	1492-GH002	1	
	0.5A	1492-GH005	1	
	0.8A	1492-GH008	1	
	1.0A	1492-GH010	1	
	1.2A	1492-GH012	1	
	1.5A	1492-GH015	1	
	2.0A	1492-GH020	1	
	2.5A	1492-GH025	1	
	3.0A	1492-GH030	1	
	4.0A	1492-GH040	1	
	5.0A	1492-GH050	1	
	7.0A	1492-GH070	1	
	10.0A	1492-GH100	1	
	15.0A	1492-GH150	1	
Accessories		Catalog No.	Pcs./ Pkg.	*
Mounting Rails: (Details Page 12-143)				
	1 Meter Symmetrical DIN	199-DR1	10	
	1 Meter Symmetrical DIN (Alumin.)	1492-DR5	10	
	1 Meter Hi-Rise Symmetrical DIN	1492-DR6	2	
	1 Meter Angled Hi-Rise Sym. DIN	1492-DR7	2	
	3' Scored Channel	1492-N1	20	
	3' Rigid Channel	1492-N22	20	
	3' Hi-Rise Channel	1492-N44	2	
	Standoff Brackets	1492-N25	2	
End Anchors: (Details Page 12-146)				
	A-B Rail — Heavy Duty	1492-N23	10	
	A-B Rail — Snap On	1492-N47	50	
	DIN Rails — Normal Duty	1492-EA35	50	
	DIN Rails — Heavy Duty	1492-EAH35	50	
Marking Systems: (See Page 12-155)				
	Group Marker (DIN Rail only)	1492-SMN83	5	
		1492-GM35	10	

● Use every 12" with **1492-N22** rail.

Description

Bulletin 1492 “High Density” circuit breakers are thermal magnetic type **supplementary** overcurrent protective devices. Bulletin 1492–GH circuit breakers are available in one pole units. The 1492–GH is rated from 0.2 to 7 amps at 240V AC and 10–15 amps at 125V AC, and has a 65V DC rating as standard. Wire termination is achieved by a clamping style, self lifting box lug.

Features

- high density design allows 24 one pole breakers per foot
- wide range of currents for precise circuit requirements
- international approvals — meets NEMA and IEC standards for worldwide acceptance
- ratings to 250V AC
- AC and DC voltage ratings — in one convenient device
- a “positively trip free” mechanism
- superior shock and vibration resistance capabilities — helps prevent nuisance tripping
- universal mounting foot for a variety of mounting channels

One Pole Style 1492–GH

Single pole high density circuit breaker that incorporates a thermal portion and a magnetic trip function for the combined advantages of two sensing systems. The 1492–GH style of breakers uses a push to set mechanism for circuit actuation and comes with a manual trip button for manually opening the circuit.

Applications

Included but not limited to the protection of test equipment, control instrumentation, solenoids and power supplies. The wide range of current values and the use of a thermal magnetic trip system allows for a variety of applications where a very accurate and compact breaker is required.

1492–GH Circuit Breakers
NEMA & IEC Rated Circuit Breakers

Selection Guide — To select a circuit breaker use the following procedure:

- Determine the inrush correction factor from Table 1.
- Determine the sealed current of the load being protected.
- Multiply the sealed current by the two correction factors and select the closest higher ampere rating.

Example — What size circuit breaker should be selected for a solenoid with sealed current of 0.5 amp, an inrush ratio of 1:8, and an ambient temperature of +110°F?

$0.5 \times 1.7 \times 1.15 = 0.9775$
 Select the 1.0 amp circuit breaker.

Inrush Ratio	1:1 to 1:4	1:5	1:6	1:7	1:8
Factor	1.3	1.4	1.5	1.6	1.7

Note: For resistive loads, use inrush correction factor of 1.0.

Ambient Temperature	70°F (21.1°C)	100°F (37.8°C)	120°F (48.9°C)	140°F (60°C)	160°F (71.1°C)	180°F (82.2°C)	200°F (93.3°C)
Factor	1.0	1.1	1.2	1.3	1.4	1.5	1.6

Tripping time of the circuit breaker is determined from Table 3 below. Divide the circuit breaker value by the temperature correction factor from Table 2 above to determine the actual rated current referenced in Table 3.

Tripping Times in Seconds at 70°F (21.1°C)								
Percent Rated Current	100%	200%	300%	400%	500%	600%	1000%	2000% Greater
Tripping Times (Seconds)	No Trip	10-40	3-18	1.5-9	0.8-6	0.003-4	0.003-2	Maximum 0.02

Note: When several breakers are rail mounted adjacent to each other, the “no-trip” current will be 80% of rated current at 70°F (21.1°C).

Trip Current

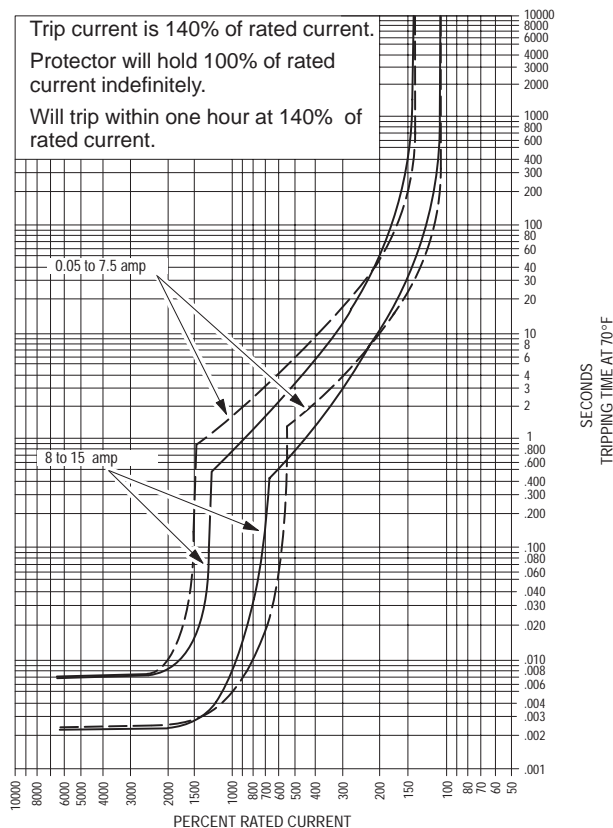

Bulletin 1492
Circuit Protection
Circuit Breakers

SPECIFICATIONS^①

Catalog Number	1492–GH Series B
Description	Single Pole with universal mounting foot for Allen-Bradley and DIN rail mounting.
Approvals ^②	 , CSA, VDE
Maximum Voltage Ratings	250V AC 50/60 Hz (0.2-7A) 125V AC 50/60 Hz (10-15A) 65V DC
Standard Current Ratings Internal Resistance per Pole	(Amps.) 0.2, 0.5, 0.8, 1.0, 1.2, 1.5, 2.0, 2.5, 3.0, 4.0, 5.0, 7.0, 10.0, 15.0 (Ohms) 44, 6.6, 2.55, 1.97, 1.22, 0.86, 0.49, 0.313, 0.205, 0.104, 0.082, 0.034 <0.20, <0.20
Dielectric Strength	1500V AC
Shock and Vibration Specifications	Shock 25G, 11ms duration Vibration: 5G (10 to 500 Hz)
Insulation Resistance	100 megaohms @ 500V DC
Current Capacity of Auxiliary Contacts (N.O., N.C.)	Not Applicable
Shunt Circuit	Not Applicable
Maximum Interrupting Capacity	200A, but not exceeding 100 times rated current. (UL tested to 1000 Amps.)
Operating Life	6000 cycles @ rated current (UL 1077) 4000 cycles @ 200% rated current
Temperature Range	-40°C to +65°C
Housing Material	Glass filled Polyamide 6.6
Wire Size	#22–#10 AWG (0.5-6 mm ²)
Recommended Wire Strip Length	0.44" (11.2 mm)
Terminals	Tubular screw with self lifting box lug.
Recommended Tightening Torque	10-12 lb.-in. (1.13-1.4 Nm)

① Performance Data — See Page Important-2.

② Circuit Breakers also meet the requirements of AS, BS and SEV.



Description

Bulletin 1492 “High Density” circuit breakers are thermal magnetic type **supplementary** overcurrent protective devices. Bulletin 1492–GS circuit breakers are available in one, two and three pole units, and all are available with an internally mounted auxillary contact. The 1492–GS is rated .2 – 25 amps at 277V/480V AC with an interrupting rating of up to 5k AIC. The 1492–GS also has a DC voltage rating of 65V DC.

Features

- “High Density” Design — allows 24 one pole breakers per foot.
- A larger current range for precise circuit requirements.
- International approvals — meets NEMA, IEC, and CE standards for worldwide acceptance

- Ratings to 480V AC for 2 and 3 pole devices, and 277V AC for single pole devices.
- Universal mounting foot for a variety of mounting channels.
- Toggle style handle for ease of operation.

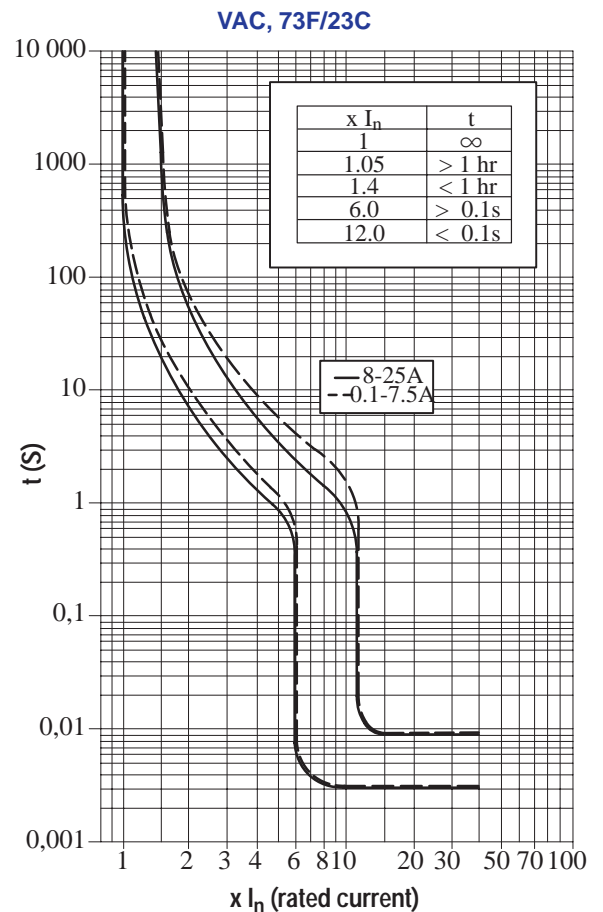
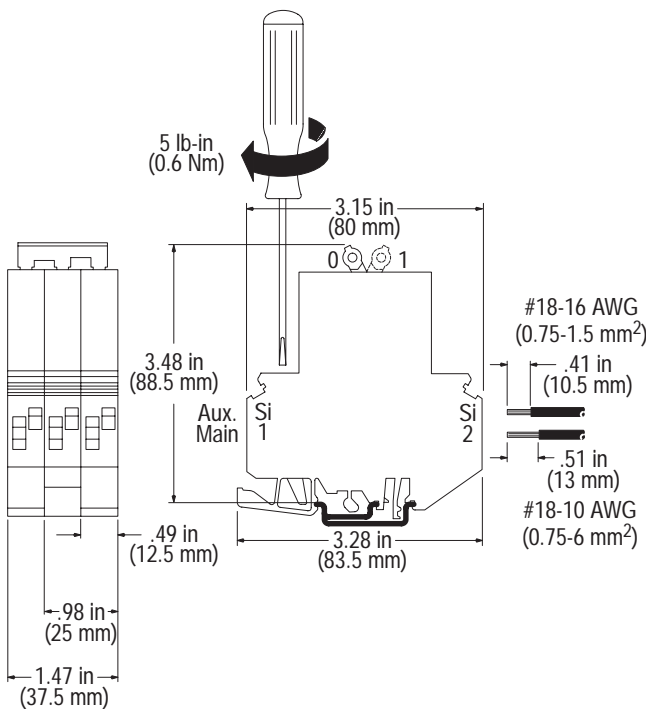

Bulletin 1492
Circuit Protection
Circuit Breakers

How to Order 1492–GS

The following information must be known to select the proper circuit breaker:

- What is the full load amperage that will be available in the system?
- Is it a 1, 2, or 3 phase system?
- What are the start-up or inrush properties of the load?

- Will the system require additional “shaping” options or auxiliary contacts?

After defining these few parameters, the selection can be done by following the chart below.

Selection Information

You can order a basic one, two, or three pole circuit breaker from the following tables and add an accessory module to meet your specific application requirements.

1492 – GS 2 G 008 – H1

Bulletin Number

Circuit Breaker	
GS	Screw Terminal

Optional Auxiliary Contacts		*
H1	Normally Open	
H2	Normally Closed	

Note: 1 contact max. for 1 pole circuit breaker. 2 contacts max for 2 and 3 pole circuit breakers.

Number of Poles		Rated Voltage By Trip Characteristic	*
		G	
1	One Pole	277V AC 65V DC	
2	Two Pole	480V AC 65V DC	
3	Three Pole	480V AC 65V DC	

Trip Characteristic	
Code	Magnetic Trip Range
G	6–10 x I _n

I_n = Rated Current

Current Rating Code (Standard Trip Characteristic is Type G)

Code	002	005	008	010	015	020	025	030	040	050	060	080	100	120	150	160	200	250
Amp Rating	0.2	0.5	0.8	1	1.5	2	2.5	3	4	5	6	8	10	12	15	16	20	25

Accessories Used with All 1492–GS Circuit Breakers

Accessory	Catalog No.	Pcs./Pkg.	*
Mounting Rails: (Details Page 12-143) 1 Meter Symmetrical DIN	199–DR1	10	
1 M Symmetrical DIN (Alumin.)	1492–DR5	10	
1 M Hi-Rise Symmetrical DIN	1492–DR6	2	
1 M Angled Hi-Rise Symmetrical DIN	1492–DR7	2	
3' Scored A–B Rail	1492–N1	10	
3' Rigid A–B Rail	1492–N22	2	
3' High Rise A–B Rail	1492–N44	2	
End Anchor DIN Rail	1492–EAH35	50	
A–B Rail (Heavy Duty)	1492–N23	10	
Group Marking (DIN Rail)	1492–GM35	10	
Marking Systems (See Page 12-155)	1492–SMN83	5	

NOTES

Programmable Controller Wiring Systems

Product Description

Allen-Bradley Interface Modules and Cables provide convenient I/O connection points to sensors and actuators, as do conventional terminal blocks. However, unlike conventional terminal blocks, they connect through pre-wired cables to digital and analog I/O modules; this can eliminate up to 50% of the point-to-point wiring between the I/O modules and sensors/actuators. Installation time is quicker than with traditional wiring methods.

Mount the interface module onto a standard DIN #3 rail. Then attach the pre-wired wiring arm or removable terminal block (at one end of the pre-wired cable) to the I/O module, and plug the connector on the other end of the cable into the interface module. The wiring systems eliminate the need to assemble rails of terminal blocks and cut, strip, label, and terminate 20 to 40 wires per I/O module, which reduces the probability of wiring errors and start-up problems.

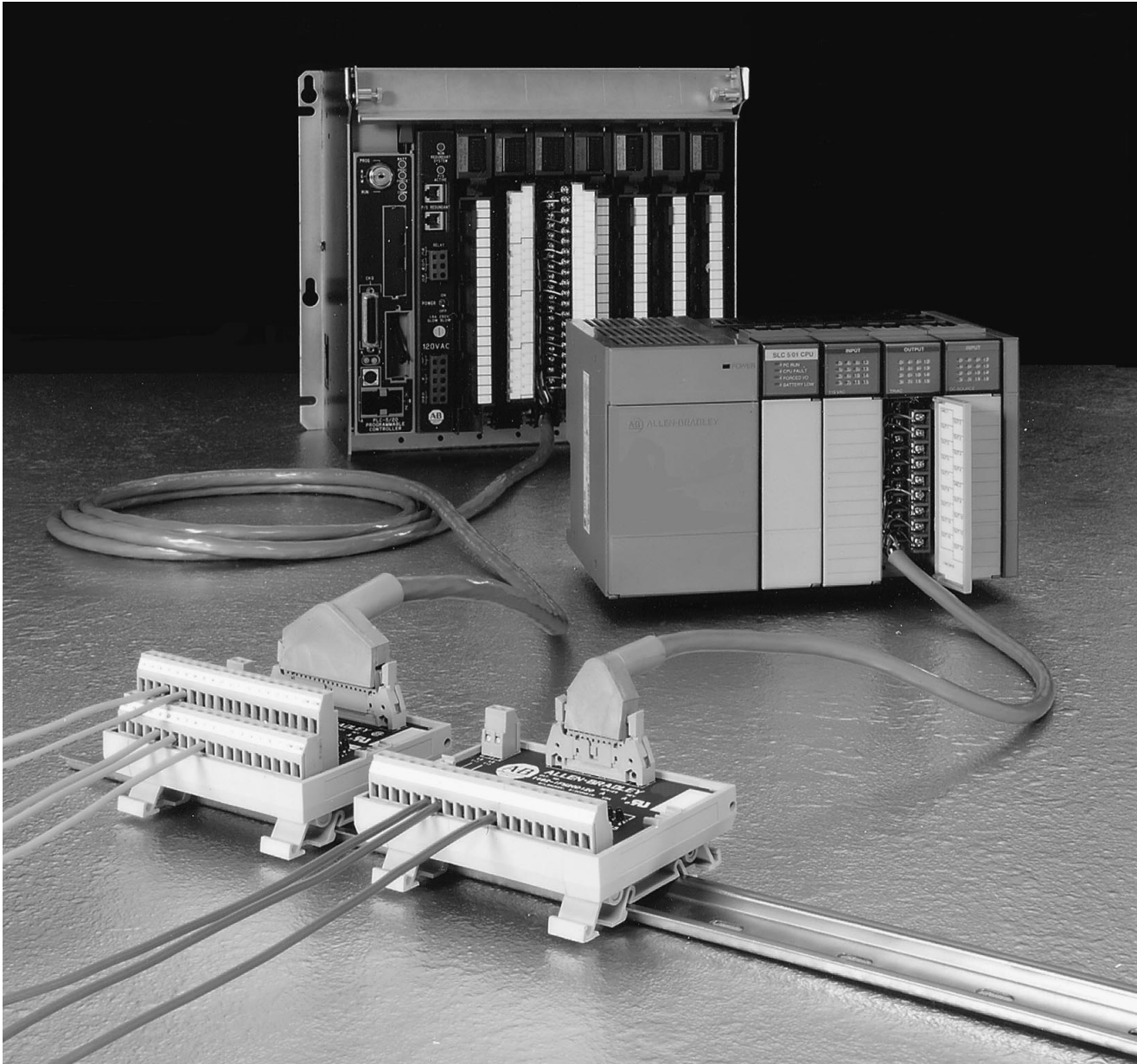

Digital Interface Module (IFM) Description

These IFMs are available with either 20- or 40-pin cable connectors. The number of terminals varies with the type of module — from one to three terminals per I/O. Standard IFMs have one terminal per I/O for applications where the device's power is terminated remotely from the I/O module panel. Extra terminal IFMs have two terminals per I/O providing a power bus to terminate the device's power connections within the I/O module panel. Sensor IFMs have three terminals per input, providing two power buses for compactly terminating three-wire sensors.

Voltage indicating LEDs are available on the standard, extra terminal and sensor IFMs. The LEDs provide troubleshooting diagnostics through the on/off status of either an input or a programmable controller output circuit. When used in conjunction with the programmable controller LEDs, the IFM LEDs can help determine if a problem resides in the I/O module or the device and wiring.

Fuse clips (5x20mm), which are available on the extra terminal IFMs, add overcurrent protection into programmable controller output wiring. Optional blown fuse indicators reduce the troubleshooting time to locate and replace a blown fuse on the IFM. A fusible IFM with blown fuse indicators is available for 24V input modules.

Analog Interface Module (AIFM) Description

These AIFMs are available with either 15- or 25-pin D-shell cable connectors. The number of terminals varies with the type of module — from three to five terminals per I/O. Feed-through AIFMs have three terminals per I/O channel to wire the I/O module connections and device shield. The 5x20mm fusible AIFMs with blown fuse indicators provide overcurrent protection for 2-, 3-, or 4-wire input transmitters. These AIFMs have up to 5 terminals per input channel to wire the input module connections, device shield, and transmitter power connections. The additional field-side terminals on both styles of AIFMs and the power busses on the fusible AIFMs eliminate the need for extra terminal blocks and jumper accessories.

Digital and Analog Interface Module Features

- Polarized connectors with locking tabs for easy installation and secure connection of pre-wired cables
- High-current interface modules allow 2A per circuit
- High-density wiring terminals allow more connections in less space
- Wiring terminals accept #22-12 AWG wire
- Pre-printed and blank adhesive marking strips provide I/O addresses or your own application identification
- Large marking area for quick identification during troubleshooting

Digital and Analog Pre-Wired Cables

The broad offering of pre-wired cables supports more than 40 different 16- and 32-I/O SLC and PLC digital I/O modules and more than 15 different 4-, 8-, and 16-channel SLC and PLC analog I/O modules. The cables are tested for continuity to help ensure a positive connection and are available in 0.5, 1.0, 2.5, and 5.0 meter lengths for a variety of applications. Custom length cables (made to order) are also available.

Digital Interface Module-Ready Cables

IFM-ready cables have a cable connector on one end to attach to the interface module (IFM) and either 20 or 40 individually colored conductors on the other. These cables allow the digital IFMs to be used in specialty applications that require custom connections.

Digital I/O Module-Ready Cables

I/O module-ready cables have a pre-wired 1771 wiring arm or 1746 removable terminal block on one end to connect to the programmable controller and 12-40 individually colored #18 AWG conductors on the other (1492-CABLE0N3 uses #22 AWG conductors). These cables provide the convenience of a pre-wired digital I/O module connector while still allowing the flexibility to wire to standard terminal blocks.

For I/O Module, Cable, and Interface Module compatibility, refer to pages 12-124 to 12-126.

Refer to the Digital I/O Wiring Systems Interface Modules and Cables Product Data (publication 1492-2.12), or the Analog I/O Wiring Systems Interface Modules and Cables Product Data (publication 1492-2.15) for more information.

Programmable Controller Wiring Systems

Digital Interface Modules

1492-IFM20F

1492-IFM20FN

1492-IFM20F-2

Dimensions are not intended for manufacturing purposes.
Note: Height dimension is measured from top of rail to top of Interface Module. Width dimension is measured **across** the rail. Length dimension is measured **along** the rail.



Specifications

20-point Interface Module.

20-point narrow Interface Module.

20-point Interface Module with extra terminals

Approvals (Details Page 12-6)			
Voltage Rating	0-132V AC/DC	0-132V AC/DC	0-132V AC/DC
Maximum Peak Voltage ^①	600V _p	600V _p	600V _p
Maximum Current (per Circuit)	2A	2A	2A
Maximum Current (per Module)	12A	12A	12A
Indicator Circuit Current (Nominal)	—	—	—
No. of Terminals per Device Common	—	—	10
Wire Range (Rated Cross Section)	#22-#12 AWG (0.2-4 mm ²)	#22-#12 AWG (0.2-4 mm ²)	#22-#12 AWG (0.2-4 mm ²)
Wire Strip Length	0.32" (8 mm)	0.32" (8 mm)	0.32" (8 mm)
Recommended Tightening Torque	3.5-4.5 lb.-in. (0.38-0.50 Nm)	3.5-4.5 lb.-in. (0.38-0.50 Nm)	3.5-4.5 lb.-in. (0.38-0.50 Nm)
Operating Temperature Range	0°C to +60°C	0°C to +60°C	0°C to +60°C
Dimensions (L x W x H)	4.33" x 3.27" x 1.67" (110 mm x 83 mm x 42.5 mm)	2.36" x 3.27" x 2.19" (60 mm x 83 mm x 55.5 mm)	4.33" x 3.27" x 2.19" (110 mm x 83 mm x 55.5 mm)

Interface Module	Catalog No.	Pcs./Pkg.	*	Catalog No.	Pcs./Pkg.	*	Catalog No.	Pcs./Pkg.	*
Interface Module:	1492-IFM20F	1		1492-IFM20FN	1		1492-IFM20F-2	1	
Accessories	Catalog No.	Pcs./Pkg.	*	Catalog No.	Pcs./Pkg.	*	Catalog No.	Pcs./Pkg.	*
Mounting Rails: (Details Page 12-143) 1 M Symmetrical DIN (Steel)	199-DR1	10		199-DR1	10		199-DR1	10	
1 M Symmetrical DIN (Alumin.)	1492-DR5	10		1492-DR5	10		1492-DR5	10	
1 M Hi-Rise Sym. DIN (Alumin.)	1492-DR6	2		1492-DR6	2		1492-DR6	2	
1 M Angled Hi-Rise Sym. DIN (Steel)	1492-DR7	2		1492-DR7	2		1492-DR7	2	
End Anchors: (Details Page 12-146) DIN Rail — Normal Duty	1492-EA35	50		1492-EA35	50		1492-EA35	50	
DIN Rail — Heavy Duty	1492-EAH35	10		1492-EAH35	10		1492-EAH35	10	
Jumpers: (Details Page 12-150) Side Jumper — 10 Pole Insulated	1492-SJM5-10	10		1492-SJM5-10	10		1492-SJM5-10	10	
Group Marking Carrier (Details Page 12-152)	1492-GM35	10		1492-GM35	10		1492-GM35	10	
Replacement Fuse Holders: (Details Page 12-150)	—	—		—	—		—	—	
Marking Systems: (Details Page 12-127)	Pre-Printed and Blank Strips Included			Pre-Printed and Blank Strips Included			Pre-Printed and Blank Strips Included		

① For transients >600Vp use a UL recognized suppression device rated at 2.5kV withstand.







Programmable Controller Wiring Systems

Digital Interface Modules

1492-IFM20F-3

1492-IFM20D24

1492-IFM20D24N

<p>Dimensions are not intended for manufacturing purposes.</p> <p>Note: Height dimension is measured from top of rail to top of Interface Module. Width dimension is measured across the rail. Length dimension is measured along the rail.</p>									
	<i>20-point Interface Module for 3-wire sensor-type input devices.</i>	<i>20-point Interface Module with 24V AC/DC LEDs</i>	<i>20-point narrow Interface Module with 24V AC/DC LEDs</i>						
Specifications									
Approvals (See Page 12-6)									
Voltage Rating	0-132V AC/DC	10-30V AC/DC	10-30V AC/DC						
Maximum Peak Voltage ^①	600V _p	600V _p	600V _p						
Maximum Current (per Circuit)	2A	2A	2A						
Maximum Current (per Module)	12A	12A	12A						
Indicator Circuit Current (Nominal)	—	2mA	2mA						
No. of Terminals per Device Common	18	16	16						
Wire Range (Rated Cross Section)	#22-#12 AWG (0.2-4 mm ²)	#22-#12 AWG (0.2-4 mm ²)	#22-#12 AWG (0.2-4 mm ²)						
Wire Strip Length	0.32" (8 mm)	0.32" (8 mm)	0.32" (8 mm)						
Recommended Tightening Torque	3.5-4.5 lb.-in. (0.38-0.50 Nm)	3.5-4.5 lb.-in. (0.38-0.50 Nm)	3.5-4.5 lb.-in. (0.38-0.50 Nm)						
Operating Temperature Range	0°C to +60°C	0°C to +60°C	0°C to +60°C						
Dimensions (L x W x H)	4.33" x 3.27" x 2.74" (110 mm x 83 mm x 69.5 mm)	4.33" x 3.27" x 1.67" (110 mm x 83 mm x 42.5 mm)	2.36" x 3.27" x 2.19" (60 mm x 83 mm x 55.5 mm)						
Interface Module	Catalog No.	Pcs./Pkg.	*	Catalog No.	Pcs./Pkg.	*	Catalog No.	Pcs./Pkg.	*
Interface Module:	1492-IFM20F-3	1		1492-IFM20D24	1		1492-IFM20D24N	1	
Accessories	Catalog No.	Pcs./Pkg.	*	Catalog No.	Pcs./Pkg.	*	Catalog No.	Pcs./Pkg.	*
Mounting Rails: (Details Page 12-143) 1 M Symmetrical DIN (Steel)	199-DR1	10		199-DR1	10		199-DR1	10	
1 M Symmetrical DIN (Alumin.)	1492-DR5	10		1492-DR5	10		1492-DR5	10	
1 M Hi-Rise Sym. DIN (Alumin.)	1492-DR6	2		1492-DR6	2		1492-DR6	2	
1 M Angled Hi-Rise Sym. DIN (Steel)	1492-DR7	2		1492-DR7	2		1492-DR7	2	
End Anchors: (Details Page 12-146) DIN Rail — Normal Duty	1492-EA35	50		1492-EA35	50		1492-EA35	50	
DIN Rail — Heavy Duty	1492-EAH35	10		1492-EAH35	10		1492-EAH35	10	
Jumpers: (Details Page 12-150) Side Jumper — 10 Pole Insulated	1492-SJM5-10	10		1492-SJM5-10	10		1492-SJM5-10	10	
Group Marking Carrier (Details Page 12-152)	1492-GM35	10		1492-GM35	10		1492-GM35	10	
Replacement Fuse Holders: (Details Page 12-150)	—	—		—	—		—	—	
Marking Systems: (Details Page 12-127)	Pre-Printed and Blank Strips Included			Pre-Printed and Blank Strips Included			Pre-Printed and Blank Strips Included		

① For transients >600Vp use a UL recognized suppression device rated at 2.5kV withstand.







Programmable Controller Wiring Systems

Digital Interface Modules

1492-IFM20D24-2

1492-IFM20D24A-2

1492-IFM20D24-3

<p>Dimensions are not intended for manufacturing purposes.</p> <p>Note: Height dimension is measured from top of rail to top of Interface Module. Width dimension is measured across the rail. Length dimension is measured along the rail.</p>						
<p>Specifications</p>	<p>20-point Interface Module with 24V AC/DC LEDs and extra terminals for outputs.</p>	<p>20-point Interface Module with 24V AC/DC LEDs and extra terminals for inputs.</p>	<p>20-point Interface Module with 24V AC/DC LEDs for 3-wire sensor type input devices.</p>			
<p>Approvals (See Page 12-6)</p>	<p> /CSA</p>	<p> /CSA</p>	<p> /CSA</p>			
<p>Voltage Rating</p>	<p>10-30V AC/DC</p>	<p>10-30V AC/DC</p>	<p>10-30V AC/DC</p>			
<p>Maximum Peak Voltage^①</p>	<p>600V_p</p>	<p>600V_p</p>	<p>600V_p</p>			
<p>Maximum Current (per Circuit)</p>	<p>2A</p>	<p>2A</p>	<p>2A</p>			
<p>Maximum Current (per Module)</p>	<p>12A</p>	<p>12A</p>	<p>12A</p>			
<p>Indicator Circuit Current (Nominal)</p>	<p>2mA</p>	<p>2mA</p>	<p>2mA</p>			
<p>No. of Terminals per Device Common</p>	<p>10</p>	<p>20</p>	<p>18</p>			
<p>Wire Range (Rated Cross Section)</p>	<p>#22-#12 AWG (0.2-4 mm²)</p>	<p>#22-#12 AWG (0.2-4 mm²)</p>	<p>#22-#12 AWG (0.2-4 mm²)</p>			
<p>Wire Strip Length</p>	<p>0.32" (8 mm)</p>	<p>0.32" (8 mm)</p>	<p>0.32" (8 mm)</p>			
<p>Recommended Tightening Torque</p>	<p>3.5-4.5 lb.-in. (0.38-0.50 Nm)</p>	<p>3.5-4.5 lb.-in. (0.38-0.50 Nm)</p>	<p>3.5-4.5 lb.-in. (0.38-0.50 Nm)</p>			
<p>Operating Temperature Range</p>	<p>0°C to +60°C</p>	<p>0°C to +60°C</p>	<p>0°C to +60°C</p>			
<p>Dimensions (L x W x H)</p>	<p>4.33" x 3.27" x 2.19" (110 mm x 83 mm x 55.5 mm)</p>	<p>4.33" x 3.27" x 2.19" (110 mm x 83 mm x 55.5 mm)</p>	<p>4.33" x 3.27" x 2.74" (110 mm x 83 mm x 69.5 mm)</p>			
<p>Interface Module</p>	<p>Catalog No.</p>	<p>Pcs./Pkg.</p>	<p>*</p>	<p>Catalog No.</p>	<p>Pcs./Pkg.</p>	<p>*</p>
<p>Interface Module:</p>	<p>1492-IFM20D24-2</p>	<p>1</p>	<p></p>	<p>1492-IFM20D24A-2</p>	<p>1</p>	<p></p>
<p>Accessories</p>	<p>Catalog No.</p>	<p>Pcs./Pkg.</p>	<p>*</p>	<p>Catalog No.</p>	<p>Pcs./Pkg.</p>	<p>*</p>
<p>Mounting Rails: (Details Page 12-143) 1 M Symmetrical DIN (Steel)</p>	<p>199-DR1</p>	<p>10</p>	<p></p>	<p>199-DR1</p>	<p>10</p>	<p></p>
<p>1 M Symmetrical DIN (Alumin.)</p>	<p>1492-DR5</p>	<p>10</p>	<p></p>	<p>1492-DR5</p>	<p>10</p>	<p></p>
<p>1 M Hi-Rise Sym. DIN (Alumin.)</p>	<p>1492-DR6</p>	<p>2</p>	<p></p>	<p>1492-DR6</p>	<p>2</p>	<p></p>
<p>1 M Angled Hi-Rise Sym. DIN (Steel)</p>	<p>1492-DR7</p>	<p>2</p>	<p></p>	<p>1492-DR7</p>	<p>2</p>	<p></p>
<p>End Anchors: (Details Page 12-146) DIN Rail — Normal Duty</p>	<p>1492-EA35</p>	<p>50</p>	<p></p>	<p>1492-EA35</p>	<p>50</p>	<p></p>
<p>DIN Rail — Heavy Duty</p>	<p>1492-EAH35</p>	<p>10</p>	<p></p>	<p>1492-EAH35</p>	<p>10</p>	<p></p>
<p>Jumpers: (Details Page 12-150) Side Jumper — 10 Pole Insulated</p>	<p>1492-SJM5-10</p>	<p>10</p>	<p></p>	<p>1492-SJM5-10</p>	<p>10</p>	<p></p>
<p>Group Marking Carrier (Details Page 12-152)</p>	<p>1492-GM35</p>	<p>10</p>	<p></p>	<p>1492-GM35</p>	<p>10</p>	<p></p>
<p>Replacement Fuse Holders: (Details Page 12-150)</p>	<p>—</p>	<p>—</p>	<p></p>	<p>—</p>	<p>—</p>	<p></p>
<p>Marking Systems: (Details Page 12-127)</p>	<p>Pre-Printed and Blank Strips Included</p>	<p>Pre-Printed and Blank Strips Included</p>	<p>Pre-Printed and Blank Strips Included</p>			

① For transients >600Vp use a UL recognized suppression device rated at 2.5kV withstand.

1492-IFM20D120

1492-IFM20D120N

Dimensions are not intended for manufacturing purposes.

Note: Height dimension is measured from top of rail to top of Interface Module. Width dimension is measured **across** the rail. Length dimension is measured **along** the rail.

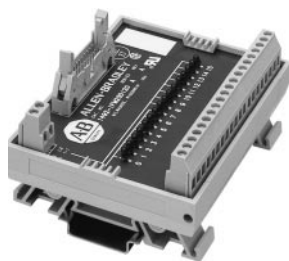

Specifications

20-point Interface Module with 120V AC/DC LEDs.

20-point narrow Interface Module with 120V AC LEDs.



Approvals (See Page 12-6)						
Voltage Rating	85-132V AC/DC			85-132V AC		
Maximum Peak Voltage ^①	600V _p			600V _p		
Maximum Current (per Circuit)	2A			2A		
Maximum Current (per Module)	12A			12A		
Indicator Circuit Current (Nominal)	2.5mA			2.5mA		
No. of Terminals per Device Common	8			16		
Wire Range (Rated Cross Section)	#22-#12 AWG (0.2-4 mm ²)			#22-#12 AWG (0.2-4 mm ²)		
Wire Strip Length	0.32" (8 mm)			0.32" (8 mm)		
Recommended Tightening Torque	3.5-4.5 lb.-in. (0.38-0.50 Nm)			3.5-4.5 lb.-in. (0.38-0.50 Nm)		
Operating Temperature Range	0°C to +60°C			0°C to +60°C		
Dimensions (L x W x H)	4.33" x 3.27" x 1.67" (110 mm x 83 mm x 42.5 mm)			2.36" x 3.27" x 2.19" (60 mm x 83 mm x 55.5 mm)		
Interface Module	Catalog No.	Pcs./Pkg.	*	Catalog No.	Pcs./Pkg.	*
Interface Module:	1492-IFM20D120	1		1492-IFM20D120N	1	
Accessories	Catalog No.	Pcs./Pkg.	*	Catalog No.	Pcs./Pkg.	*
Mounting Rails: (Details Page 12-143) 1 M Symmetrical DIN (Steel)	199-DR1	10		199-DR1	10	
1 M Symmetrical DIN (Alumin.)	1492-DR5	10		1492-DR5	10	
1 M Hi-Rise Sym. DIN (Alumin.)	1492-DR6	2		1492-DR6	2	
1 M Angled Hi-Rise Sym. DIN (Steel)	1492-DR7	2		1492-DR7	2	
End Anchors: (Details Page 12-146) DIN Rail — Normal Duty	1492-EA35	50		1492-EA35	50	
DIN Rail — Heavy Duty	1492-EAH35	10		1492-EAH35	10	
Jumpers: (Details Page 12-150) Side Jumper — 10 Pole Insulated	1492-SJM5-10	10		1492-SJM5-10	10	
Group Marking Carrier (Details Page 12-152)	1492-GM35	10		1492-GM35	10	
Replacement Fuse Holders: (Details Page 12-150)	—	—		—	—	
Marking Systems: (Details Page 12-127)	Pre-Printed and Blank Strips Included			Pre-Printed and Blank Strips Included		

① For transients >600Vp use a UL recognized suppression device rated at 2.5kV withstand.

Programmable Controller Wiring Systems

Digital Interface Modules

1492-IFM20D120-2 1492-IFM20D120A-2

<p>Dimensions are not intended for manufacturing purposes.</p> <p>Note: Height dimension is measured from top of rail to top of Interface Module. Width dimension is measured across the rail. Length dimension is measured along the rail.</p>						
	<p>20-point Interface Module with 120V AC LEDs and extra terminals for outputs.</p>			<p>20-point Interface Module with 120V AC LEDs and extra terminals for inputs.</p>		
Specifications						
Approvals (See Page 12-6)	UL/CSA			UL/CSA		
Voltage Rating	85-132V AC			85-132V AC		
Maximum Peak Voltage ^①	600V _p			600V _p		
Maximum Current (per Circuit)	2A			2A		
Maximum Current (per Module)	12A			12A		
Indicator Circuit Current (Nominal)	2.5mA			2.5mA		
No. of Terminals per Device Common	10			20		
Wire Range (Rated Cross Section)	#22-#12 AWG (0.2-4 mm ²)			#22-#12 AWG (0.2-4 mm ²)		
Wire Strip Length	0.32" (8 mm)			0.32" (8 mm)		
Recommended Tightening Torque	3.5-4.5 lb.-in. (0.38-0.50 Nm)			3.5-4.5 lb.-in. (0.38-0.50 Nm)		
Operating Temperature Range	0°C to +60°C			0°C to +60°C		
Dimensions (L x W x H)	4.33" x 3.27" x 2.19" (110 mm x 83 mm x 55.5 mm)			4.33" x 3.27" x 2.19" (110 mm x 83 mm x 55.5 mm)		
Interface Module	Catalog No.	Pcs./Pkg.	*	Catalog No.	Pcs./Pkg.	*
Interface Module:	1492-IFM20D120-2	1		1492-IFM20D120A-2	1	
Accessories	Catalog No.	Pcs./Pkg.	*	Catalog No.	Pcs./Pkg.	*
Mounting Rails: (Details Page 12-143) 1 M Symmetrical DIN (Steel)	199-DR1	10		199-DR1	10	
1 M Symmetrical DIN (Alumin.)	1492-DR5	10		1492-DR5	10	
1 M Hi-Rise Sym. DIN (Alumin.)	1492-DR6	2		1492-DR6	2	
1 M Angled Hi-Rise Sym. DIN (Steel)	1492-DR7	2		1492-DR7	2	
End Anchors: (Details Page 12-146) DIN Rail — Normal Duty	1492-EA35	50		1492-EA35	50	
DIN Rail — Heavy Duty	1492-EAH35	10		1492-EAH35	10	
Jumpers: (Details Page 12-150) Side Jumper — 10 Pole Insulated	1492-SJM5-10	10		1492-SJM5-10	10	
Group Marking Carrier (Details Page 12-152)	1492-GM35	10		1492-GM35	10	
Replacement Fuse Holders: (Details Page 12-150)	—	—		—	—	
Marking Systems: (Details Page 12-127)	Pre-Printed and Blank Strips Included			Pre-Printed and Blank Strips Included		

① For transients >600Vp use a UL recognized suppression device rated at 2.5kV withstand.







Programmable Controller Wiring Systems

Digital Interface Modules

1492-IFM20F-F-2

1492-IFM20F-F24-2

1492-IFM20F-F120-2

<p>Dimensions are not intended for manufacturing purposes.</p> <p>Note: Height dimension is measured from top of rail to top of Interface Module. Width dimension is measured across the rail. Length dimension is measured along the rail.</p>									
Specifications	<p><i>20-point Interface Module with 5 x 20mm fuse clips and extra terminals for outputs.</i></p>	<p><i>20-point Interface Module with 5 x 20mm fuse clips, 24V AC/DC blown fuse indicators, and extra terminals for outputs.</i></p>	<p><i>20-point Interface Module with 5 x 20mm fuse clips, 120V AC blown fuse indicators, and extra terminals for outputs.</i></p>						
Approvals (See Page 12-6)	 /CSA	 /CSA	 /CSA						
Voltage Rating	0-132V AC/DC	10-30V AC/DC	85-132V AC						
Maximum Peak Voltage [Ⓜ]	600V _p	600V _p	600V _p						
Maximum Current (per Circuit)	2A	2A	2A						
Maximum Current (per Module)	12A	12A	12A						
Indicator Circuit Current (Nominal)	—	2mA	2.5mA						
No. of Terminals per Device Common	10	10	10						
Wire Range (Rated Cross Section)	#22-#12 AWG (0.2-4 mm ²)	#22-#12 AWG (0.2-4 mm ²)	#22-#12 AWG (0.2-4 mm ²)						
Wire Strip Length	0.32" (8 mm)	0.32" (8 mm)	0.32" (8 mm)						
Recommended Tightening Torque	3.5-4.5 lb.-in. (0.38-0.50 Nm)	3.5-4.5 lb.-in. (0.38-0.50 Nm)	3.5-4.5 lb.-in. (0.38-0.50 Nm)						
Operating Temperature Range	0°C to +60°C	0°C to +60°C	0°C to +60°C						
Dimensions (L x W x H)	4.33" x 3.27" x 2.19" (110 mm x 83 mm x 55.5 mm)	4.33" x 3.27" x 2.19" (110 mm x 83 mm x 55.5 mm)	4.33" x 3.27" x 2.19" (110 mm x 83 mm x 55.5 mm)						
Interface Module	Catalog No.	Pcs./Pkg.	*	Catalog No.	Pcs./Pkg.	*	Catalog No.	Pcs./Pkg.	*
Interface Module:	1492-IFM20F-F-2	1		1492-IFM20F-F24-2	1		1492-IFM20F-F120-2	1	
Accessories	Catalog No.	Pcs./Pkg.	*	Catalog No.	Pcs./Pkg.	*	Catalog No.	Pcs./Pkg.	*
Mounting Rails: (Details Page 12-143) 1 M Symmetrical DIN (Steel)	199-DR1	10		199-DR1	10		199-DR1	10	
1 M Symmetrical DIN (Alumin.)	1492-DR5	10		1492-DR5	10		1492-DR5	10	
1 M Hi-Rise Sym. DIN (Alumin.)	1492-DR6	2		1492-DR6	2		1492-DR6	2	
1 M Angled Hi-Rise Sym. DIN (Steel)	1492-DR7	2		1492-DR7	2		1492-DR7	2	
End Anchors: (Details Page 12-146) DIN Rail — Normal Duty	1492-EA35	50		1492-EA35	50		1492-EA35	50	
DIN Rail — Heavy Duty	1492-EAH35	10		1492-EAH35	10		1492-EAH35	10	
Jumpers: (Details Page 12-150) Side Jumper — 10 Pole Insulated	1492-SJM5-10	10		1492-SJM5-10	10		1492-SJM5-10	10	
Group Marking Carrier (Details Page 12-152)	1492-GM35	10		1492-GM35	10		1492-GM35	10	
Replacement Fuse Holders: (Details Page 12-150) [Ⓜ]	1492-IFMFH1 [Ⓜ]	20		1492-IFMFH1 [Ⓜ]	20		1492-IFMFH1 [Ⓜ]	20	
Marking Systems: (Details Page 12-127)	Pre-Printed and Blank Strips Included			Pre-Printed and Blank Strips Included			Pre-Printed and Blank Strips Included		

[Ⓜ] 20 Fuse Holders are included with Catalog Numbers 1492-IFM20F-F-2, 1492-IFM20F-F24-2 and 1492-IFM20F-F120-2.

[Ⓜ] For transients >600Vp use a UL recognized suppression device rated at 2.5kV withstand.

Programmable Controller Wiring Systems
Digital Interface Modules

1492-IFM20F-F24A-2

<p>Dimensions are not intended for manufacturing purposes.</p> <p>Note: Height dimension is measured from top of rail to top of Interface Module. Width dimension is measured across the rail. Length dimension is measured along the rail.</p>	
--	---

Specifications	20-point Interface Module with 5 x 20mm fuse clips, 24V AC/DC blown fuse indicators, and extra terminals for inputs.
Approvals (See Page 12-6)	 /CSA
Voltage Rating	10-30V AC/DC
Maximum Peak Voltage [Ⓜ]	600V _p
Maximum Current (per Circuit)	2A
Maximum Current (per Module)	12A
Indicator Circuit Current (Nominal)	2mA
No. of Terminals per Device Common	10
Wire Range (Rated Cross Section)	#22-#12 AWG (0.2-4 mm ²)
Wire Strip Length	0.32" (8 mm)
Recommended Tightening Torque	3.5-4.5 lb.-in. (0.38-0.50 Nm)
Operating Temperature Range	0°C to +60°C
Dimensions (L x W x H)	4.33" x 3.27" x 2.19" (110 mm x 83 mm x 55.5 mm)

Interface Module	Catalog No.	Pcs./Pkg.	*
Interface Module:	1492-IFM20F-F24A-2	1	
Accessories	Catalog No.	Pcs./Pkg.	*
Mounting Rails: (Details Page 12-143) 1 M Symmetrical DIN (Steel)	199-DR1	10	
1 M Symmetrical DIN (Alumin.)	1492-DR5	10	
1 M Hi-Rise Sym. DIN (Alumin.)	1492-DR6	2	
1 M Angled Hi-Rise Sym. DIN (Steel)	1492-DR7	2	
End Anchors: (Details Page 12-146) DIN Rail — Normal Duty	1492-EA35	50	
DIN Rail — Heavy Duty	1492-EAH35	10	
Jumpers: (Details Page 12-150) Side Jumper — 10 Pole Insulated	1492-SJM5-10	10	
Group Marking Carrier (Details Page 12-152)	1492-GM35	10	
Replacement Fuse Holders: (Details Page 12-150) [Ⓛ]	1492-IFMFH1 [Ⓛ]	20	
Marking Systems: (Details Page 12-127)	Pre-Printed and Blank Strips Included		

- Ⓛ 20 Fuse Holders are included with Catalog Number 1492-IFM20F-F24A-2.
- Ⓜ For transients >600Vp use a UL recognized suppression device rated at 2.5kV withstand.

Programmable Controller Wiring Systems

Digital Interface Modules

1492-IFM40F

1492-IFM40F-2

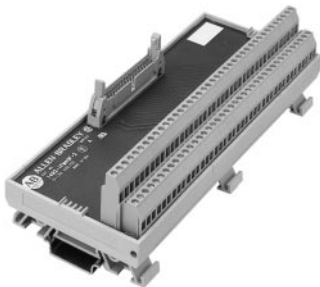
<p>Dimensions are not intended for manufacturing purposes.</p> <p>Note: Height dimension is measured from top of rail to top of Interface Module. Width dimension is measured across the rail. Length dimension is measured along the rail.</p>						
	40-point Interface Module.			40-point Interface Module with extra terminals.		
Specifications						
Approvals (See Page 12-6)	UL/CSA			UL/CSA		
Voltage Rating	0-132V AC/DC			0-132V AC/DC		
Maximum Peak Voltage ^①	600V _p			600V _p		
Maximum Current (per Circuit)	2A			2A		
Maximum Current (per Module)	12A			12A		
Indicator Circuit Current (Nominal)	—			—		
No. of Terminals per Device Common	—			10		
Wire Range (Rated Cross Section)	#22-#12 AWG (0.2-4 mm ²)			#22-#12 AWG (0.2-4 mm ²)		
Wire Strip Length	0.32" (8 mm)			0.32" (8 mm)		
Recommended Tightening Torque	3.5-4.5 lb.-in. (0.38-0.50 Nm)			3.5-4.5 lb.-in. (0.38-0.50 Nm)		
Operating Temperature Range	0°C to +60°C			0°C to +60°C		
Dimensions (L x W x H)	4.33" x 3.27" x 2.19" (110 mm x 83 mm x 55.5 mm)			8.27" x 3.27" x 2.19" (210 mm x 83 mm x 55.5 mm)		
Interface Module	Catalog No.	Pcs./ Pkg.	*	Catalog No.	Pcs./ Pkg.	*
Interface Module:	1492-IFM40F	1		1492-IFM40F-2	1	
Accessories	Catalog No.	Pcs./ Pkg.	*	Catalog No.	Pcs./ Pkg.	*
Mounting Rails: (Details Page 12-143) 1 M Symmetrical DIN (Steel)	199-DR1	10		199-DR1	10	
1 M Symmetrical DIN (Alumin.)	1492-DR5	10		1492-DR5	10	
1 M Hi-Rise Sym. DIN (Alumin.)	1492-DR6	2		1492-DR6	2	
1 M Angled Hi-Rise Sym. DIN (Steel)	1492-DR7	2		1492-DR7	2	
End Anchors: (Details Page 12-146) DIN Rail — Normal Duty	1492-EA35	50		1492-EA35	50	
DIN Rail — Heavy Duty	1492-EAH35	10		1492-EAH35	10	
Jumpers: (Details Page 12-150) Side Jumper — 10 Pole Insulated	1492-SJM5-10	10		1492-SJM5-10	10	
Group Marking Carrier (Details Page 12-152)	1492-GM35	10		1492-GM35	10	
Replacement Fuse Holders: (Details Page 12-150)	—	—		—	—	
Marking Systems: (Details Page 12-127)	Pre-Printed and Blank Strips Included			Pre-Printed and Blank Strips Included		



① For transients >600Vp use a UL recognized suppression device rated at 2.5kV withstand.

Programmable Controller Wiring Systems

Digital Interface Modules

1492-IFM40F-3

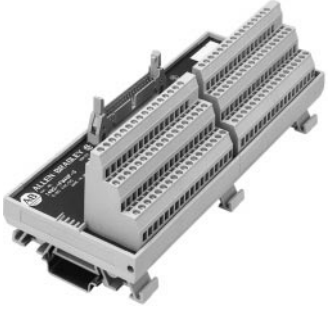
1492-IFM40D24

<p>Dimensions are not intended for manufacturing purposes.</p> <p>Note: Height dimension is measured from top of rail to top of Interface Module. Width dimension is measured across the rail. Length dimension is measured along the rail.</p>						
	<p><i>40-point Interface Module for 3-wire sensor-type input devices.</i></p>			<p><i>40-point Interface Module with 24V AC/DC LEDs</i></p>		
Specifications						
Approvals (See Page 12-6)	UL /CSA			UL /CSA		
Voltage Rating	0-60V AC/DC			10-30V AC/DC		
Maximum Peak Voltage ^①	600V _p			600V _p		
Maximum Current (per Circuit)	2A			2A		
Maximum Current (per Module)	12A			12A		
Indicator Circuit Current (Nominal)	—			2mA		
No. of Terminals per Device Common	18			32		
Wire Range (Rated Cross Section)	#22-#12 AWG (0.2-4 mm ²)			#22-#12 AWG (0.2-4 mm ²)		
Wire Strip Length	0.32" (8 mm)			0.32" (8 mm)		
Recommended Tightening Torque	3.5-4.5 lb.-in. (0.38-0.50 Nm)			3.5-4.5 lb.-in. (0.38-0.50 Nm)		
Operating Temperature Range	0°C to +60°C			0°C to +60°C		
Dimensions (L x W x H)	8.27" x 3.27" x 2.74" (210 mm x 83 mm x 69.5 mm)			4.33" x 3.27" x 2.19" (110 mm x 83 mm x 55.5 mm)		
Interface Module	Catalog No.	Pcs./ Pkg.	*	Catalog No.	Pcs./ Pkg.	*
Interface Module:	1492-IFM40F-3	1		1492-IFM40D24	1	
Accessories	Catalog No.	Pcs./ Pkg.	*	Catalog No.	Pcs./ Pkg.	*
Mounting Rails: (Details Page 12-143) 1 M Symmetrical DIN (Steel)	199-DR1	10		199-DR1	10	
1 M Symmetrical DIN (Alumin.)	1492-DR5	10		1492-DR5	10	
1 M Hi-Rise Sym. DIN (Alumin.)	1492-DR6	2		1492-DR6	2	
1 M Angled Hi-Rise Sym. DIN (Steel)	1492-DR7	2		1492-DR7	2	
End Anchors: (Details Page 12-146) DIN Rail — Normal Duty	1492-EA35	50		1492-EA35	50	
DIN Rail — Heavy Duty	1492-EAH35	10		1492-EAH35	10	
Jumpers: (Details Page 12-150) Side Jumper — 10 Pole Insulated	1492-SJM5-10	10		1492-SJM5-10	10	
Group Marking Carrier (Details Page 12-152)	1492-GM35	10		1492-GM35	10	
Replacement Fuse Holders: (Details Page 12-150)	—	—		—	—	
Marking Systems: (Details Page 12-127)	Pre-Printed and Blank Strips Included			Pre-Printed and Blank Strips Included		

① For transients >600Vp use a UL recognized suppression device rated at 2.5kV withstand.

Programmable Controller Wiring Systems

Digital Interface Modules

1492-IFM40D24-2

1492-IFM40D24A-2

Dimensions are not intended for manufacturing purposes.

Note: Height dimension is measured from top of rail to top of Interface Module. Width dimension is measured **across** the rail. Length dimension is measured **along** the rail.

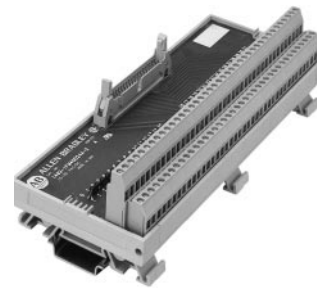

Specifications

*40-point Interface Module
with 24V AC/DC LEDs and extra terminals for outputs.*

*40-point Interface Module
with 24V AC/DC LEDs and extra terminals for inputs.*

Approvals (See Page 12-6)	UL /CSA			UL /CSA		
Voltage Rating	10-30V AC/DC			10-30V AC/DC		
Maximum Peak Voltage ^①	600V _p			600V _p		
Maximum Current (per Circuit)	2A			2A		
Maximum Current (per Module)	12A			12A		
Indicator Circuit Current (Nominal)	2mA			2mA		
No. of Terminals per Device Common	10			10		
Wire Range (Rated Cross Section)	#22-#12 AWG (0.2-4 mm ²)			#22-#12 AWG (0.2-4 mm ²)		
Wire Strip Length	0.32" (8 mm)			0.32" (8 mm)		
Recommended Tightening Torque	3.5-4.5 lb.-in. (0.38-0.50 Nm)			3.5-4.5 lb.-in. (0.38-0.50 Nm)		
Operating Temperature Range	0°C to +60°C			0°C to +60°C		
Dimensions (L x W x H)	8.27" x 3.27" x 2.19" (210 mm x 83 mm x 55.5 mm)			8.27" x 3.27" x 2.19" (210 mm x 83 mm x 55.5 mm)		
Interface Module	Catalog No.	Pcs./ Pkg.	*	Catalog No.	Pcs./ Pkg.	*
Interface Module:	1492-IFM40D24-2	1		1492-IFM40D24A-2	1	
Accessories	Catalog No.	Pcs./ Pkg.	*	Catalog No.	Pcs./ Pkg.	*
Mounting Rails: (Details Page 12-143) 1 M Symmetrical DIN (Steel)	199-DR1	10		199-DR1	10	
1 M Symmetrical DIN (Alumin.)	1492-DR5	10		1492-DR5	10	
1 M Hi-Rise Sym. DIN (Alumin.)	1492-DR6	2		1492-DR6	2	
1 M Angled Hi-Rise Sym. DIN (Steel)	1492-DR7	2		1492-DR7	2	
End Anchors: (Details Page 12-146) DIN Rail — Normal Duty	1492-EA35	50		1492-EA35	50	
DIN Rail — Heavy Duty	1492-EAH35	10		1492-EAH35	10	
Jumpers: (Details Page 12-150) Side Jumper — 10 Pole Insulated	1492-SJM5-10	10		1492-SJM5-10	10	
Group Marking Carrier (Details Page 12-152)	1492-GM35	10		1492-GM35	10	
Replacement Fuse Holders: (Details Page 12-150)	—	—		—	—	
Marking Systems: (Details Page 12-127)	Pre-Printed and Blank Strips Included			Pre-Printed and Blank Strips Included		

① For transients >600Vp use a UL recognized suppression device rated at 2.5kV withstand.

1492-IFM40D24-3

1492-IFM40D120-2

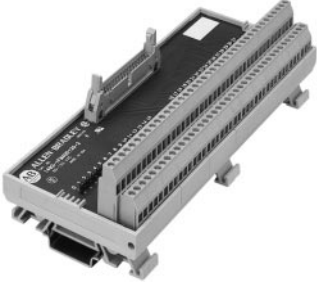
<p>Dimensions are not intended for manufacturing purposes.</p> <p>Note: Height dimension is measured from top of rail to top of Interface Module. Width dimension is measured across the rail. Length dimension is measured along the rail.</p>		
--	---	---

Specifications	<i>40-point Interface Module with 24V AC/DC LEDs for 3-wire sensor-type input devices.</i>			<i>40-point Interface Module with 120V AC LEDs and extra terminals for outputs.</i>		
Approvals (See Page 12-6)	UL /CSA			UL /CSA		
Voltage Rating	10-30V AC/DC			85-132V AC		
Maximum Peak Voltage ^①	600V _p			600V _p		
Maximum Current (per Circuit)	2A			2A		
Maximum Current (per Module)	12A			12A		
Indicator Circuit Current (Nominal)	2mA			2.5mA		
No. of Terminals per Device Common	18			10		
Wire Range (Rated Cross Section)	#22-#12 AWG (0.2-4 mm ²)			#22-#12 AWG (0.2-4 mm ²)		
Wire Strip Length	0.32" (8 mm)			0.32" (8 mm)		
Recommended Tightening Torque	3.5-4.5 lb.-in. (0.38-0.50 Nm)			3.5-4.5 lb.-in. (0.38-0.50 Nm)		
Operating Temperature Range	0°C to +60°C			0°C to +60°C		
Dimensions (L x W x H)	8.27" x 3.27" x 2.74" (210 mm x 83 mm x 69.5 mm)			8.27" x 3.27" x 2.19" (210 mm x 83 mm x 55.5 mm)		
Interface Module	Catalog No.	Pcs./ Pkg.	*	Catalog No.	Pcs./ Pkg.	*
Interface Module:	1492-IFM40D24-3	1		1492-IFM40D120-2	1	
Accessories	Catalog No.	Pcs./ Pkg.	*	Catalog No.	Pcs./ Pkg.	*
Mounting Rails: (Details Page 12-143) 1 M Symmetrical DIN (Steel)	199-DR1	10		199-DR1	10	
1 M Symmetrical DIN (Alumin.)	1492-DR5	10		1492-DR5	10	
1 M Hi-Rise Sym. DIN (Alumin.)	1492-DR6	2		1492-DR6	2	
1 M Angled Hi-Rise Sym. DIN (Steel)	1492-DR7	2		1492-DR7	2	
End Anchors: (Details Page 12-146) DIN Rail — Normal Duty	1492-EA35	50		1492-EA35	50	
DIN Rail — Heavy Duty	1492-EAH35	10		1492-EAH35	10	
Jumpers: (Details Page 12-150) Side Jumper — 10 Pole Insulated	1492-SJM5-10	10		1492-SJM5-10	10	
Group Marking Carrier (Details Page 12-152)	1492-GM35	10		1492-GM35	10	
Replacement Fuse Holders: (Details Page 12-150)	—	—		—	—	
Marking Systems: (Details Page 12-127)	Pre-Printed and Blank Strips Included			Pre-Printed and Blank Strips Included		





① For transients >600Vp use a UL recognized suppression device rated at 2.5kV withstand.

Programmable Controller Wiring Systems

Digital Interface Modules

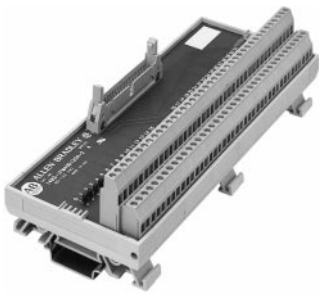
1492-IFM40D120A-2

1492-IFM40F-F-2

<p>Dimensions are not intended for manufacturing purposes.</p> <p>Note: Height dimension is measured from top of rail to top of Interface Module. Width dimension is measured across the rail. Length dimension is measured along the rail.</p>						
Specifications	40-point Interface Module with 120V AC LEDs and extra terminals for inputs.	40-point Interface Module with 5 x 20mm fuse clips and extra terminals.				
Approvals (See Page 12-6)	 /CSA	 /CSA				
Voltage Rating	85-132V AC	0-132V AC/DC				
Maximum Peak Voltage [Ⓜ]	600V _p	600V _p				
Maximum Current (per Circuit)	2A	2A				
Maximum Current (per Module)	12A	12A				
Indicator Circuit Current (Nominal)	2.5mA	—				
No. of Terminals per Device Common	10	10				
Wire Range (Rated Cross Section)	#22-#12 AWG (0.2-4 mm ²)	#22-#12 AWG (0.2-4 mm ²)				
Wire Strip Length	0.32" (8 mm)	0.32" (8 mm)				
Recommended Tightening Torque	3.5-4.5 lb.-in. (0.38-0.50 Nm)	3.5-4.5 lb.-in. (0.38-0.50 Nm)				
Operating Temperature Range	0°C to +60°C	0°C to +60°C				
Dimensions (L x W x H)	8.27" x 3.27" x 2.19" (210 mm x 83 mm x 55.5 mm)	8.27" x 3.27" x 2.19" (210 mm x 83 mm x 55.5 mm)				
Interface Module	Catalog No.	Pcs./ Pkg.	*	Catalog No.	Pcs./ Pkg.	*
Interface Module:	1492-IFM40D120A-2	1		1492-IFM40F-F-2	1	
Accessories	Catalog No.	Pcs./ Pkg.	*	Catalog No.	Pcs./ Pkg.	*
Mounting Rails: (Details Page 12-143) 1 M Symmetrical DIN (Steel)	199-DR1	10		199-DR1	10	
1 M Symmetrical DIN (Alumin.)	1492-DR5	10		1492-DR5	10	
1 M Hi-Rise Sym. DIN (Alumin.)	1492-DR6	2		1492-DR6	2	
1 M Angled Hi-Rise Sym. DIN (Steel)	1492-DR7	2		1492-DR7	2	
End Anchors: (Details Page 12-146) DIN Rail — Normal Duty	1492-EA35	50		1492-EA35	50	
DIN Rail — Heavy Duty	1492-EAH35	10		1492-EAH35	10	
Jumpers: (Details Page 12-150) Side Jumper — 10 Pole Insulated	1492-SJM5-10	10		1492-SJM5-10	10	
Group Marking Carrier (Details Page 12-152)	1492-GM35	10		1492-GM35	10	
Replacement Fuse Holders: (Details Page 12-150) [Ⓛ]	—	—		1492-IFMFH1 [Ⓛ]	20	
Marking Systems: (Details Page 12-127)	Pre-Printed and Blank Strips Included			Pre-Printed and Blank Strips Included		

[Ⓛ] 40 Fuse Holders are included with Catalog Number: 1492-IFM40F-F-2.



[Ⓜ] For transients >600Vp use a UL recognized suppression device rated at 2.5kV withstand.

Programmable Controller Wiring Systems

Digital Interface Modules

1492-IFM40F-F24-2

1492-IFM40F-F120-2







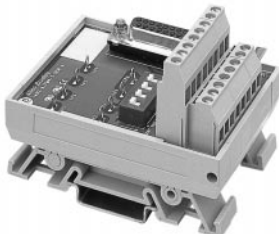
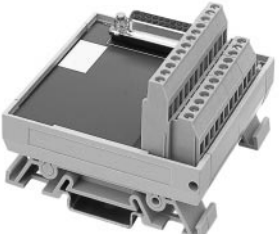

<p>Dimensions are not intended for manufacturing purposes.</p> <p>Note: Height dimension is measured from top of rail to top of Interface Module. Width dimension is measured across the rail. Length dimension is measured along the rail.</p>						
	<p>40-point Interface Module with 5 x 20mm fuse clips, 24V AC/DC blown fuse indicators, and extra terminals.</p>			<p>40-point Interface Module with 5 x 20mm fuse clips, 120V AC blown fuse indicators, and extra terminals.</p>		
Specifications						
Approvals (See Page 12-6)	UL /CSA			UL /CSA		
Voltage Rating	10-30V AC/DC			85-132V AC		
Maximum Peak Voltage ^②	600V _p			600V _p		
Maximum Current (per Circuit)	2A			2A		
Maximum Current (per Module)	12A			12A		
Indicator Circuit Current (Nominal)	2mA			2.5mA		
No. of Terminals per Device Common	10			10		
Wire Range (Rated Cross Section)	#22-#12 AWG (0.2-4 mm ²)			#22-#12 AWG (0.2-4 mm ²)		
Wire Strip Length	0.32" (8 mm)			0.32" (8 mm)		
Recommended Tightening Torque	3.5-4.5 lb.-in. (0.38-0.50 Nm)			3.5-4.5 lb.-in. (0.38-0.50 Nm)		
Operating Temperature Range	0°C to +60°C			0°C to +60°C		
Dimensions (L x W x H)	8.27" x 3.27" x 2.19" (210 mm x 83 mm x 55.5 mm)			8.27" x 3.27" x 2.19" (210 mm x 83 mm x 55.5 mm)		
Interface Module	Catalog No.	Pcs./ Pkg.	*	Catalog No.	Pcs./ Pkg.	*
Interface Module:	1492-IFM40F-F24-2	1		1492-IFM40F-F120-2	1	
Accessories	Catalog No.	Pcs./ Pkg.	*	Catalog No.	Pcs./ Pkg.	*
Mounting Rails: (Details Page 12-143) 1 M Symmetrical DIN (Steel)	199-DR1	10		199-DR1	10	
1 M Symmetrical DIN (Alumin.)	1492-DR5	10		1492-DR5	10	
1 M Hi-Rise Sym. DIN (Alumin.)	1492-DR6	2		1492-DR6	2	
1 M Angled Hi-Rise Sym. DIN (Steel)	1492-DR7	2		1492-DR7	2	
End Anchors: (Details Page 12-146) DIN Rail — Normal Duty	1492-EA35	50		1492-EA35	50	
DIN Rail — Heavy Duty	1492-EAH35	10		1492-EAH35	10	
Jumpers: (Details Page 12-150) Side Jumper — 10 Pole Insulated	1492-SJM5-10	10		1492-SJM5-10	10	
Group Marking Carrier (Details Page 12-152)	1492-GM35	10		1492-GM35	10	
Replacement Fuse Holders: (Details Page 12-150) ①	1492-IFMFH1 ①	20		1492-IFMFH1 ①	20	
Marking Systems: (Details Page 12-127)	Pre-Printed and Blank Strips Included			Pre-Printed and Blank Strips Included		

① 40 Fuse Holders are included with Catalog Numbers: 1492-IFM40F-F24-2, and 1492-IFM40F-F120-2.

② For transients >600Vp use a UL recognized suppression device rated at 2.5kV withstand.

Programmable Controller Wiring Systems

Analog Interface Modules

	1492-AIFM4-3	1492-AIFM6S-3	1492-AIFM8-3						
<p>Dimensions are not intended for manufacturing purposes.</p> <p>Note: Height dimension is measured from top of rail to top of Interface Module. Width dimension is measured across the rail. Length dimension is measured along the rail.</p>									
Specifications	4-channel IFM with 3 terminals per channel and optional 250Ω current limit resistors for 1771-OFE	6-channel isolated IFM with 3-4 terminals per channel	8-channel IFM with 3 terminals per channel						
Approvals (See Page 12-6)	 	 	 						
Voltage Rating	0-132V AC/DC	0-132V AC/DC	0-132V AC/DC						
Maximum Peak Voltage ^①	600V _p	600V _p	600V _p						
Maximum Current (per Circuit)	2A	2A	2A						
Maximum Current (per Module)	12A	12A	12A						
Indicator Circuit Current (Nominal)	—	—	—						
No. of Terminals per Shield Common	4	6	8						
Wire Range (Rated Cross Section)	#22-#12 AWG (0.2-4 mm ²)	#22-#12 AWG (0.2-4 mm ²)	#22-#12 AWG (0.2-4 mm ²)						
Wire Strip Length	0.32" (8 mm)	0.32" (8 mm)	0.32" (8 mm)						
Recommended Tightening Torque	3.5-4.5 lb.-in. (0.38-0.50 Nm)	3.5-4.5 lb.-in. (0.38-0.50 Nm)	3.5-4.5 lb.-in. (0.38-0.50 Nm)						
Operating Temperature Range	0°C to +60°C	0°C to +60°C	0°C to +60°C						
Dimensions (L x W x H)	2.36" x 3.27" x 2.19" (60 mm x 83 mm x 55.5 mm)	3.15" x 3.27" x 2.19" (80 mm x 83 mm x 55.5 mm)	4.33" x 3.27" x 2.19" (110 mm x 83 mm x 55.5 mm)						
Interface Module	Catalog No.	Pcs./Pkg.	*	Catalog No.	Pcs./Pkg.	*	Catalog No.	Pcs./Pkg.	*
Interface Module:	1492-AIFM4-3	1		1492-AIFM6S-3	1		1492-AIFM8-3	1	
Accessories	Catalog No.	Pcs./Pkg.	*	Catalog No.	Pcs./Pkg.	*	Catalog No.	Pcs./Pkg.	*
Mounting Rails: (Details Page 12-143)									
1 M Symmetrical DIN (Steel)	199-DR1	10		199-DR1	10		199-DR1	10	
1 M Symmetrical DIN (Alumin.)	1492-DR5	10		1492-DR5	10		1492-DR5	10	
1 M Hi-Rise Sym. DIN (Alumin.)	1492-DR6	2		1492-DR6	2		1492-DR6	2	
1 M Angled Hi-Rise Sym. DIN (Steel)	1492-DR7	2		1492-DR7	2		1492-DR7	2	
End Anchors: (Details Page 12-146)									
DIN Rail — Normal Duty	1492-EA35	50		1492-EA35	50		1492-EA35	50	
DIN Rail — Heavy Duty	1492-EAH35	10		1492-EAH35	10		1492-EAH35	10	
Jumpers: (Details Page 12-150)									
Side Jumper — 10 Pole Insulated	1492-SJM5-10	10		1492-SJM5-10	10		1492-SJM5-10	10	
Group Marking Carrier (Details Page 12-152)	1492-GM35	10		1492-GM35	10		1492-GM35	10	
Replacement Fuse Holders: (Details Page 12-150)	—	—		—	—		—	—	
Marking Systems: (Details Page 12-127)	Pre-Printed and Blank Strips Included			Pre-Printed and Blank Strips Included			Pre-Printed and Blank Strips Included		

① For transients >600Vp use a UL recognized suppression device rated at 2.5kV withstand.

Programmable Controller Wiring Systems

Analog Interface Modules

1492-AIFM4I-F-5

1492-AIFM4C-F-5

1492-AIFM8-F-5

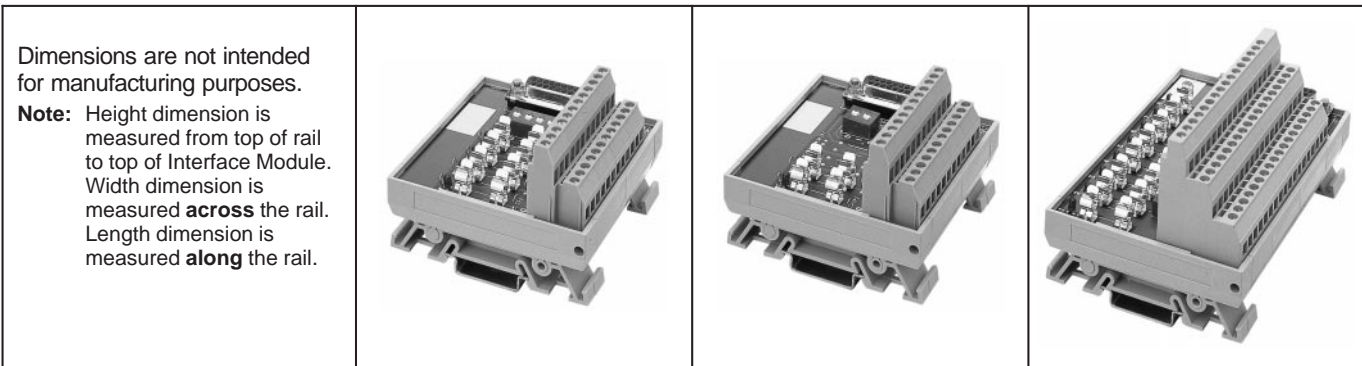

Dimensions are not intended for manufacturing purposes.
Note: Height dimension is measured from top of rail to top of Interface Module. Width dimension is measured **across** the rail. Length dimension is measured **along** the rail.

Specifications	1492-AIFM4I-F-5	1492-AIFM4C-F-5	1492-AIFM8-F-5
Approvals (Details Page 12-6)			
Voltage Rating	10–30V DC	10–30V DC	10–30V DC
Maximum Peak Voltage ^①	600V _p	600V _p	600V _p
Maximum Current (per Circuit)	2A	2A	2A
Maximum Current (per Module)	12A	12A	12A
Indicator Circuit Current (Nominal)	2mA	2mA	2mA
No. of Terminals per Shield Common	4	4	18
Wire Range (Rated Cross Section)	#22-#12 AWG (0.2-4 mm ²)	#22-#12 AWG (0.2-4 mm ²)	#22-#12 AWG (0.2-4 mm ²)
Wire Strip Length	0.32" (8 mm)	0.32" (8 mm)	0.32" (8 mm)
Recommended Tightening Torque	3.5-4.5 lb.-in. (0.38-0.50 Nm)	3.5-4.5 lb.-in. (0.38-0.50 Nm)	3.5-4.5 lb.-in. (0.38-0.50 Nm)
Operating Temperature Range	0°C to +60°C	0°C to +60°C	0°C to +60°C
Dimensions (L x W x H)	3.15" x 3.27" x 2.19" (80 mm x 83 mm x 55.5 mm)	3.15" x 3.27" x 2.19" (80 mm x 83 mm x 55.5 mm)	4.72" x 3.27" x 2.74" (120 mm x 83 mm x 69.5 mm)

Interface Module	Catalog No.	Pcs./Pkg.	*	Catalog No.	Pcs./Pkg.	*	Catalog No.	Pcs./Pkg.	*
Interface Module:	1492-AIFM4I-F-5	1		1492-AIFM4C-F-5	1		1492-AIFM8-F-5	1	

Accessories	Catalog No.	Pcs./Pkg.	*	Catalog No.	Pcs./Pkg.	*	Catalog No.	Pcs./Pkg.	*
Mounting Rails: (Details Page 12-143) 1 M Symmetrical DIN (Steel)	199-DR1	10		199-DR1	10		199-DR1	10	
1 M Symmetrical DIN (Alumin.)	1492-DR5	10		1492-DR5	10		1492-DR5	10	
1 M Hi-Rise Sym. DIN (Alumin.)	1492-DR6	2		1492-DR6	2		1492-DR6	2	
1 M Angled Hi-Rise Sym. DIN (Steel)	1492-DR7	2		1492-DR7	2		1492-DR7	2	
End Anchors: (Details Page 12-146) DIN Rail — Normal Duty	1492-EA35	50		1492-EA35	50		1492-EA35	50	
DIN Rail — Heavy Duty	1492-EAH35	10		1492-EAH35	10		1492-EAH35	10	
Jumpers: (Details Page 12-150) Side Jumper — 10 Pole Insulated	1492-SJM5-10	10		1492-SJM5-10	10		1492-SJM5-10	10	
Group Marking Carrier (Details Page 12-152)	1492-GM35	10		1492-GM35	10		1492-GM35	10	
Replacement Fuse Holders: ^② (Details Page 12-150)	1492-IFMFH1 ^②	20		1492-IFMFH1 ^②	20		1492-IFMFH1 ^②	20	
Marking Systems: (Details Page 12-127)	Pre-Printed and Blank Strips Included			Pre-Printed and Blank Strips Included			Pre-Printed and Blank Strips Included		







^① For transients >600Vp use a UL recognized suppression device rated at 2.5kV withstand.
^② 10 Fuse Holders are included with Catalog Numbers: 1492-AIFM4I-F-5, 1492-AIFM4C-F-5, and 1492-AIFM8-F-5.

Programmable Controller Wiring Systems

Analog Interface Modules

1492-AIFM16-F-3

1492-AIFM16-F-5

<p>Dimensions are not intended for manufacturing purposes.</p> <p>Note: Height dimension is measured from top of rail to top of Interface Module. Width dimension is measured across the rail. Length dimension is measured along the rail.</p>						
Specifications	16-channel fusible IFM with 24V blown fuse indicators and 3 terminals per input.	16-channel fusible IFM with 24V blown fuse indicators and 5 terminals per input				
Approvals (Details Page 12-6)	 / 	 / 				
Voltage Rating	10–30V DC	10–30V DC				
Maximum Recurring Peak Voltage ^①	600V _p	600V _p				
Maximum Current (per Circuit)	2A	2A				
Maximum Current (per Module)	12A	12A				
Indicator Circuit Current (Nominal)	2mA	2mA				
No. of Terminals per Shield Common	18	16				
Wire Range (Rated Cross Section)	#22-#12 AWG (0.2-4 mm ²)	#22-#12 AWG (0.2-4 mm ²)				
Wire Strip Length	0.32" (8 mm)	0.32" (8 mm)				
Recommended Tightening Torque	3.5-4.5 lb.-in. (0.38-0.50 Nm)	3.5-4.5 lb.-in. (0.38-0.50 Nm)				
Operating Temperature Range	0°C to +60°C	0°C to +60°C				
Dimensions (L x W x H)	4.72" x 3.27" x 2.74" (120 mm x 83 mm x 69.5 mm)	8.27" x 3.27" x 2.74" (210 mm x 83 mm x 69.5 mm)				
Interface Module	Catalog No.	Pcs./ Pkg.	*	Catalog No.	Pcs./ Pkg.	*
Interface Module:	1492-AIFM16-F-3	1		1492-AIFM16-F-5	1	
Accessories	Catalog No.	Pcs./ Pkg.	*	Catalog No.	Pcs./ Pkg.	*
Mounting Rails: (Details Page 12-143) 1 M Symmetrical DIN (Steel)	199-DR1	10		199-DR1	10	
1 M Symmetrical DIN (Alumin.)	1492-DR5	10		1492-DR5	10	
1 M Hi-Rise Sym. DIN (Alumin.)	1492-DR6	2		1492-DR6	2	
1 M Angled Hi-Rise Sym. DIN (Steel)	1492-DR7	2		1492-DR7	2	
End Anchors: (Details Page 12-146) DIN Rail — Normal Duty	1492-EA35	50		1492-EA35	50	
DIN Rail — Heavy Duty	1492-EAH35	10		1492-EAH35	10	
Jumpers: (Details Page 12-150) Side Jumper — 10 Pole Insulated	1492-SJM5-10	10		1492-SJM5-10	10	
Group Marking Carrier (Details Page 12-152)	1492-GM35	10		1492-GM35	10	
Replacement Fuse Holders: ^② (Details Page 12-150)	1492-IFMFH1 ^②	20		1492-IFMFH1 ^②	20	
Marking Systems: (Details Page 12-127)	Pre-Printed and Blank Strips Included			Pre-Printed and Blank Strips Included		

① For transients >600Vp use a UL recognized suppression device rated at 2.5kV withstand.

② 20 Fuse Holders are included with Catalog Numbers: 1492-AIFM16-F-3 and 1492-AIFM16-F-5.

Programmable Controller Wiring Systems

Cable Specifications

Digital Pre-wired Cable Specifications

Catalog Number and Length ^①	Insulation Rating	Conductor Size	I/O Module Connector	*			
				0.5 m	1.0 m	2.5m	5.0m
1492-CABLE ^① A	300V 80°C	#22 AWG	1746-RT25R Red Removable Terminal Block				
1492-CABLE ^① B	300V 80°C	#22 AWG	1746-RT25B Blue Removable Terminal Block				
1492-CABLE ^① C ^②	300V 80°C	#22 AWG	1746-RT25R Red Removable Terminal Block				
1492-CABLE ^① D ^②	300V 80°C	#22 AWG	1746-RT25C Orange Removable Terminal Block				
1492-CABLE ^① E	300V 80°C	#22 AWG	1746-RT25B Blue Removable Terminal Block				
1492-CABLE ^① F	300V 80°C	#22 AWG	1771-WH (16-Point/21 Terminal) Wiring Arm				
1492-CABLE ^① FF	300V 80°C	#22 AWG	1771-WHF (16-Point/21 Terminal) Fused Wiring Arm				
1492-CABLE ^① G ^③	300V 80°C	#22 AWG	1746-RT25R Red Removable Terminal Block				
1492-CABLE ^① H	300V 80°C	#22 AWG	1746-N3 (32-Point/40 Pin) Connector				
1492-CABLE ^① J	300V 80°C	#22 AWG	1771-WN (32-Point/40 Terminal) Wiring Arm				
1492-CABLE ^① K	300V 80°C	#22 AWG	1771-WN (32-Point/40 Terminal) Wiring Arm				
1492-CABLE ^① L	300V 80°C	#22 AWG	1771-WN (32-Point/40 Terminal) Wiring Arm				
1492-CABLE ^① M	300V 80°C	#22 AWG	1771-WN (32-Point/40 Terminal) Wiring Arm				
1492-CABLE ^① N ^③	300V 80°C	#22 AWG	1746-RT25C Orange Removable Terminal Block				
1492-CABLE ^① R	300V 80°C	#22 AWG	1771-WN (32-Point/40 Terminal) Wiring Arm				

- ① Cables are available in lengths of 0.5m, 1.0m, 2.5m and 5.0m. To order, insert the desired cable length code into the Catalog Number (“005” = 0.5m, “010” = 1.0m, “025” = 2.5m and “050” = 5.0m). **Example:** Catalog Number **1492-CABLE005A** is for a 0.5m cable for the **1746-IA16** I/O Module. See also Custom Lengths.
- ② Cable not for use with narrow IFMs (1492-IFM20__N).
- ③ Cable **only** for use with narrow IFMs (1492-IFM20__N).

Analog Pre-wired Cable Specifications

Catalog Number and Length ^①	Insulation Rating	Conductor Size	I/O Module Connector	General Description ^②	*			
					0.5 m	1.0 m	2.5m	5.0m
1492-ACABLE ^① A	300V 80°C	#22 AWG	1746-RT28 12-Position Removable Terminal Block	5 Twisted Pairs				
1492-ACABLE ^① B	300V 80°C	#22 AWG	1746-RT26 2-Position and 1746-RT27 8-Position Removable Terminal Block	5 Twisted Pairs				
1492-ACABLE ^① C	300V 80°C	#24 AWG	1746-RT25G Green Removable Terminal Block	9 Twisted Pairs				
1492-ACABLE ^① D	300V 80°C	#22 AWG	1746-RT25G Green Removable Terminal Block	20 Conductors				
1492-ACABLE ^① E	300V 80°C	#24 AWG	1771-WG (21 terminal) Wiring Arm	9 Twisted Pairs				
1492-ACABLE ^① F	300V 80°C	#22 AWG	1771-WG (21 terminal) Wiring Arm	20 Conductors				
1492-ACABLE ^① G	300V 80°C	#22 AWG	1771-WC (10 terminal) Wiring Arm	5 Twisted Pairs				
1492-ACABLE ^① H	300V 80°C	#24 AWG	1771-WF (18 terminal) Wiring Arm	9 Twisted Pairs				
1492-ACABLE ^① J	300V 80°C	#22 AWG	1771-WF (18 terminal) Wiring Arm	20 Conductors				
1492-ACABLE ^① L	300V 80°C	#22 AWG	1746-RT28 12-Position Removable Terminal Block	5 Twisted Pairs				

- ① Cables are available in lengths of 0.5m, 1.0m, 2.5m and 5.0m. To order, insert the desired cable length code into the Catalog Number (“005” = 0.5m, “010” = 1.0m, “025” = 2.5m and “050” = 5.0m). **Example:** Catalog Number **1492-ACABLE005A** is for a 0.5m cable for the **1746-NI4** I/O Module. See also Custom Lengths.
- ② All pre-wired analog cables have an overall shield. On 1492-ACABLE^①C and 1492-ACABLE^①D the drain wire is connected to the shield terminal on the I/O module connector. All other 1492-ACABLEs have a ring lug on the 7.87" (200mm) exposed drain wire at the I/O module end of the cable.

Programmable Controller Wiring Systems

Cable Specifications

Digital IFM-Ready Cable Specifications

Catalog Number and Length ^①	Insulation Rating	No. of Conductors	Conductor Size	Current/Conductor	Compatible IFMs	*		
						1.0 m	2.5 m	5.0 m
1492-CABLE ^① P	300V 80°C	20	#22 AWG	2 Amps	IFM20_ _ _			
1492-CABLE ^① Q	300V 80°C	40	#22 AWG	2 Amps	IFM40_ _ _			

① Cables are available in lengths of 1.0m, 2.5m and 5.0m. To order, insert the desired cable length code into the Catalog Number (“010” = 1.0m, “025” = 2.5m and “050” = 5.0m). **Example:** Catalog Number **1492-CABLE025P** is for a 2.5m cable for an IFM20_ __. See also Custom Lengths.

Digital I/O Module-Ready Cable Specifications

Catalog Number and Length ^①	Insulation Rating	No. of Conductors	Conductor Size	I/O Module Connector	*		
					1.0 m	2.5 m	5.0 m
1492-CABLE ^① N3	300V 80°C	40	#22 AWG	1746-N3 (32-Point/40 Pin) Connector			
1492-CABLE ^① RTBB	300V 80°C	20 ^②	#18 AWG	1746-RT25B Blue Removable Terminal Block			
1492-CABLE ^① RTBO	300V 80°C	20 ^②	#18 AWG	1746-RT25C Orange Removable Terminal Block			
1492-CABLE ^① RTBR	300V 80°C	20 ^②	#18 AWG	1746-RT25R Red Removable Terminal Block			
1492-CABLE ^① WA	300V 80°C	12 ^②	#18 AWG	1771-WA (8-Point/10 Terminal) Wiring Arm			
1492-CABLE ^① WD	300V 80°C	12	#18 AWG	1771-WD (8-Point/12 Terminal) Wiring Arm			
1492-CABLE ^① WH	300V 80°C	20	#18 AWG	1771-WH (16-Point/21 Terminal) Wiring Arm			
1492-CABLE ^① WHF	300V 80°C	20	#18 AWG	1771-WHF (16-Point/21 Terminal) Fused Wiring Arm			
1492-CABLE ^① WN	300V 80°C	40	#18 AWG	1771-WN (32-Point/40 Terminal) Wiring Arm			

① Cables are available in lengths of 1.0m, 2.5m and 5.0m. To order, insert the desired cable length code into the Catalog Number (“010” = 1.0m, “025” = 2.5m and “050” = 5.0m). **Example:** Catalog Number **1492-CABLE025WH** is for a 2.5m cable with a pre-wired **1771-WH** Wiring Arm on one end. See also Custom Lengths.

② Two conductors are not wired to I/O module connector.

Custom Lengths

All 1492 Cables are available in custom lengths. Contact your local Allen–Bradley Distributor or sales office for availability.

Length	Increment Size	Cable Length Codes	Examples
0.1m–2.0m	0.1m	001–020	1492-CABLE015A
2.0m–10.0m	0.5m	020–100	1492-CABLE075P
10.0m–99.0m	1.0m	100–990	1492-CABLE150RTBB

Note: Some I/O modules may have recommended maximum cable lengths. For example, the recommended maximum cable length for the 1746-IB32 and -IV32 is 10m and for the 1746-OB32 and -OV32 is 3m. Refer to the appropriate I/O module product datas for more information.

Programmable Controller Wiring Systems

Digital Cable Compatibility Table

Pre-wired Cable and IFM Selection Tables for Digital I/O Modules

To Use:

- Select the appropriate table.
- Locate your I/O Module in one of the shaded areas.
- Follow down the selected column to the cable selection code that indicates the compatible IFMs. If the space is blank, the I/O Module and IFM are not recommended for use together.

Note: To configure a cable catalog number, order **1492-CABLE00**.

① Cables are available in 0.5, 1.0, 2.5, and 5.0 m lengths. Insert the cable length code into the catalog number. Cable length codes are as follows (“005”=0.5m, “010”=1.0m, “025”=2.5m, and “050”=5.0m).

② Insert cable selection code. Example: **1492-CABLE025FF** is a 2.5m, 16-point fused, wiring arm cable for the **1771-OAD** output module.

SLC 500 8-Point Isolated and 16-Point Digital 1746 I/O Modules

Type of IFM	Description	IFM Catalog Number	I/O Module Catalog Number																
			1746-IA16	1746-IB16	1746-IC16	1746-IG16	1746-IH16	1746-IN16	1746-ITB16	1746-ITV16	1746-IV16	1746-OA16	1746-OB16	1746-OBP16	1746-OG16	1746-OV16	1746-OVP16	1746-OW16	1746-OX8
Feed-Through	20-Point Standard	1492-IFM20F	A	B	B	E	B	B	B	B	B	C	E	E	E	E	E	D	D
	20-Point Narrow Standard	1492-IFM20FN	A	B	B	E	B	B	B	B	B	G	E	E	E	E	E	N	N
	20-Point Extra Terminal	1492-IFM20F-2	A	B	B	E	B	B	B	B	B	C	E	E	E	E	E	D	
	20-Point Sensor	1492-IFM20F-3	A	B	B	E	B	B	B	B	B								
LED Indicating	20-Point Standard with 24V LEDs	1492-IFM20D24		B				B	B	B	B		E	E		E	E	D	
	20-Point Narrow Standard with 24V LEDs	1492-IFM20D24N		B				B	B	B	B		E	E		E	E	N	
	20-Point Standard with 120V LEDs	1492-IFM20D120	A				B					C						D	
	20-Point Narrow Standard with 120V LEDs	1492-IFM20D120N	A									G						N	
	20-Point Extra Terminal with 24V LEDs for Outputs	1492-IFM20D24-2											E	E		E	E	D	
	20-Point Extra Terminal with 24V LEDs for Inputs	1492-IFM20D24A-2		B				B	B	B	B								
	20-Point Extra Terminal with 120V LEDs for Outputs	1492-IFM20D120-2										C						D	
	20-Point Extra Terminal with 120V LEDs for Inputs	1492-IFM20D120A-2	A																
Fusible	20-Point Sensor with 24V LEDs	1492-IFM20D24-3		B				B	B	B	B								
	20-Point Extra Terminal for Outputs	1492-IFM20F-F-2										C	E	E		E	E	D	
	20-Point Extra Terminal with 24V Blown Fuse Indicators for Outputs	1492-IFM20F-F24-2											E	E		E	E	D	
	20-Point Extra Terminal with 120V Blown Fuse Indicators for Outputs	1492-IFM20F-F120-2										C						D	
20-Point Extra Terminal with 24V Blown Fuse Indicators for Inputs	1492-IFM20F-F24A-2		B				B	B							E	E			

PLC 16-Point Digital 1771 I/O Modules

Type of IFM	Description	IFM Catalog Number	I/O Module Cat. No.									
			1771-IAD	1771-IBD	1771-ICD	1771-IGD	1771-IND	1771-OAD	1771-OBD	1771-OGD	1771-OND	
Feed-Through	20-Point Standard	1492-IFM20F	F	F	F	F	F	F	F,FF	F,FF	F	F,FF
	20-Point Narrow Standard	1492-IFM20FN	F	F	F	F	F	F	F,FF	F,FF	F	F,FF
	20-Point Extra Terminal	1492-IFM20F-2	F	F	F	F	F	F	F,FF	F,FF	F	F,FF
	20-Point Sensor	1492-IFM20F-3	F	F	F	F	F					
LED Indicating	20-Point Standard with 24V LEDs	1492-IFM20D24		F	F		F	F,FF	F,FF		F,FF	
	20-Point Narrow Standard with 24V LEDs	1492-IFM20D24N		F	F		F	F,FF	F,FF		F,FF	
	20-Point Standard with 120V LEDs	1492-IFM20D120	F									
	20-Point Narrow Standard with 120V LEDs	1492-IFM20D120N	F					F,FF				
	20-Point Extra Terminal with 24V LEDs for Outputs	1492-IFM20D24-2						F,FF	F,FF		F,FF	
	20-Point Extra Terminal with 24V LEDs for Inputs	1492-IFM20D24A-2		F	F		F					
	20-Point Extra Terminal with 120V LEDs for Outputs	1492-IFM20D120-2						F,FF				
	20-Point Extra Terminal with 120V LEDs for Inputs	1492-IFM20D120A-2	F									
Fusible	20-Point Sensor with 24V LEDs	1492-IFM20D24-3		F	F							
	20-Point Extra Terminal for Outputs	1492-IFM20F-F-2						F	F		F	
	20-Point Extra Terminal with 24V Blown Fuse Indicators for Outputs	1492-IFM20F-F24-2						F	F		F	
	20-Point Extra Terminal with 120V Blown Fuse Indicators for Outputs	1492-IFM20F-F120-2						F				
20-Point Extra Terminal with 24V Blown Fuse Indicators for Inputs	1492-IFM20-F24A-2		F	F		F						

Programmable Controller Wiring Systems

Digital Cable Compatibility Table

Pre-wired Cable and IFM Selection Tables for Digital I/O Modules

SLC 500 32-Point Digital 1746 I/O Modules

Type of IFM	Description	IFM Catalog Number	I/O Module Catalog No.			
			1746-IB32	1746-IV32	1746-OB32	1746-OV32
Feed-Through	40-Point Standard	1492-IFM40F	H	H	H	H
	40-Point Extra Terminal	1492-IFM40F-2	H	H	H	H
	40-Point Sensor	1492-IFM40F-3	H	H		
LED Indicating	40-Point Standard with 24V LEDs	1492-IFM40D24	H	H	H	H
	40-Point Extra Terminal with 24V LEDs for Outputs	1492-IFM40D24-2			H	H
	40-Point Extra Terminal with 24V LEDs for Inputs	1492-IFM40D24A-2	H	H		
	40-Point Extra Terminal with 120V LEDs for Outputs	1492-IFM40D120-2				
	40-Point Extra Terminal with 120V LEDs for Inputs	1492-IFM40D120A-2				
	40-Point Sensor with 24V LEDs	1492-IFM40D24-3	H	H		
Fusible	40-Point Extra Terminal for Outputs	1492-IFM40F-F-2			H	H
	40-Point Extra Terminal with 24V Blown Fuse Indicators for Outputs	1492-IFM40F-F24-2			H	H
	40-Point Extra Terminal with 120V Blown Fuse Indicators for Outputs	1492-IFM40F-F120-2				

❶ 5.0m cable length is not recommended for use with the 1746-OB32 and 1746-OV32 SLC Output Modules.

PLC 16-Point Isolated and 32-Point Digital 1771 I/O Modules

Type of IFM	Description	IFM Catalog Number	I/O Module Cat. No.													
			1771-IAN	1771-IBN	1771-ID16	1771-IQ16	1771-IVN	1771-OAN	1771-OBN	1771-OD16	1771-ODD	1771-OQ16	1771-OVN	1771-OW16	1771-OWN	1771-OWNNA
Feed-Through	40-Point Standard	1492-IFM40F	J	J	M	M	K	L	L	M	M	M	L	R	L	L
	40-Point Extra Terminal	1492-IFM40F-2	J	J			K	L	L				L	R	L	L
	40-Point Sensor	1492-IFM40F-3		J			K									
LED Indicating	40-Point Standard with 24V LEDs	1492-IFM40D24		J			K		L				L		L	L
	40-Point Extra Terminal with 24V LEDs for Outputs	1492-IFM40D24-2							L				L		L	L
	40-Point Extra Terminal with 24V LEDs for Inputs	1492-IFM40D24A-2		J			K									
	40-Point Extra Terminal with 120V LEDs for Outputs	1492-IFM40D120-2							L						L	L
	40-Point Extra Terminal with 120V LEDs for Inputs	1492-IFM40D120A-2		J												
	40-Point Sensor with 24V LEDs	1492-IFM40D24-3		J			K									
Fusible	40-Point Extra Terminal for Outputs	1492-IFM40F-F-2							L	L				L	L	L
	40-Point Extra Terminal with 24V Blown Fuse Indicators for Outputs	1492-IFM40F-F24-2							L				L	L	L	L
	40-Point Extra Terminal with 120V Blown Fuse Indicators for Outputs	1492-IFM40F-F120-2							L						L	L

Programmable Controller Wiring Systems

Analog Cable Compatibility Table

Pre-wired Cable and AIFM Selection Tables for Analog I/O Modules

To Use:

- Locate your I/O Module in one of the shaded areas.
- Follow down the selected column to the cable selection code that indicates the compatible AIFMs. If the space is blank, the I/O Module and AIFM are not recommended for use together.

Note: To configure a cable catalog number, order **1492-ACABLE000**.

❶ Cables are available in 0.5, 1.0, 2.5, and 5.0 m lengths. Insert the cable length code into the catalog number. Cable length codes are as follows (“005”=0.5m, “010”=1.0m, “025”=2.5m, and “050”=5.0m).

❷ Insert cable selection code. Example: **1492-ACABLE005A** is a 0.5m cable for the **1746-NI4** I/O module.

SLC 500 1746 and PLC 1771 Analog I/O Modules

Type of IFM	Description	AIFM Catalog Number	I/O Module Catalog Number																	
			1746-FIO4I	1746-FIO4V	1746-NI4	1746-NI8	1746-NIO4I	1746-NIO4V	1746-NO4I	1746-NO4V	1746-NR4	1771-IFE (Differential)	1771-IFE (Single-Ended)	1771-IL	1771-IR	1771-OFE1	1771-OFE2	1771-OFE3		
Feed-Through	4-Channel with 3 Terminals per Channel and Optional 250Ω Current Limit Resistors for 1771-OFE	1492-AIFM4-3	L	L	A		L	L	B	B								G	G	G
	6-Channel isolated with 3-4 Terminals per Channel	1492-AIFM6S-3									D			J						
	8-Channel with 3 Terminals per Channel	1492-AIFM8-3				C						E	F	H						
Fusible	4-Channel with 24V Blown Fuse Indicators, test points, and 5 Terminals per Input	1492-AIFM4I-F-5			A															
	2-Channel with 24V Blown Fuse Indicators, tests points, 5 Terminals per Input, and 3 terminals per output	1492-AIFM4C-F-5	L	L			L	L												
	8-Channel with 24V Blown Fuse Indicators and 5 Terminals per Input	1492-AIFM8-F-5				C						E								
	16-Channel with 24V Blown Fuse Indicators and 3 Terminals per Input	1492-AIFM16-F-3											F							
	16-Channel with 24V Blown Fuse Indicators and 5 Terminals per Input	1492-AIFM16-F-5											F							

Pre-printed and Blank Adhesive Label Cards

All Bulletin 1492 IFMs and AIFMs come with an adhesive label card. The label card provides the field-side connection descriptions for the programmable controller I/O module. The label strips basically copy the wiring descriptions from the I/O module in the chassis down to the IFM terminals on the DIN rail.

The label cards list all of the compatible I/O modules and their respective wiring descriptions. Depending on the I/O module that is used, the label strip(s) are simply peeled from the label card and applied to the field-side terminals on the IFM. Refer to the respective I/O Module Product Data for actual wiring connections and recommendations.

Labels are provided in the octal and decimal numbering systems for 1746 I/O modules. Labels for 1771 I/O modules are supplied in the octal numbering system, like the I/O modules themselves. IFMs with LEDs or fuse clips come with the LEDs or fuse clips/blown fuse indicators numbered in decimal. LED and fuse labels are also provided in octal for use with 1771 I/O modules. The LED or fuse conversion label(s) would be placed directly on the circuit board of the IFM. For extra terminal modules, pre-printed labels are provided to identify the power bus(es) or commoned terminals (middle and/or lower rows of terminals) on the IFM. For each I/O module, corresponding labels with L1, L2, COM, or +V are provided. The labels indicate isolated power busses or grouped commons with a different letter or number. For example, L1-A, L1-B, L1-C or CM1, CM2, CM3, etc.

In addition, if generic numbering of the field-side terminals is desired, "Numeric" labels are provided. Examples: 1-20, 1-40, and evens and odds. For write-on identification, the label cards contain blank label strips (for field-side terminals) and rectangular boxes (for the large group marking area on each IFM or AIFM).

The 14 different labels are shown actual size on Pages 12-128 through 12-141. This information is helpful for determining field-side wiring layouts prior to installation.

An example of how the labels are applied is shown below:

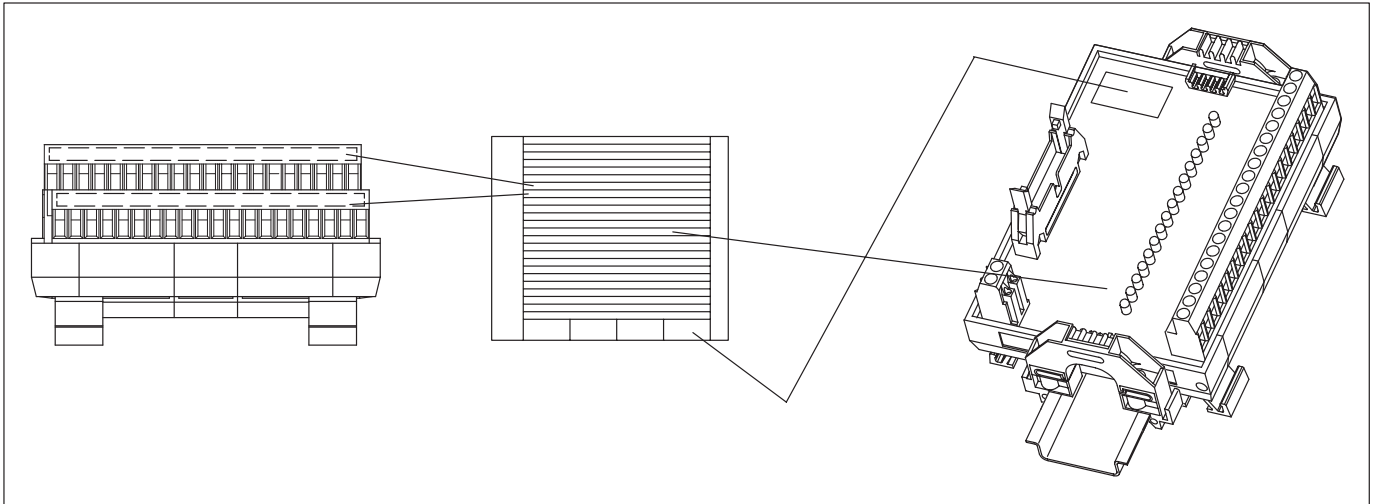

Bulletin 1492
Programmable Controller Wiring Systems
Marking Systems

Adhesive Label Card for Catalog Numbers 1492-IFM20F, -IFM20D24, -IFM20D120

I/O CAT. NO.	MODULE LABEL																			
1746-IA16, IN16	0	1	2	3	4	5	6	7	8	9	10	11	12	13	14	15	L2	L2		
	00	01	02	03	04	05	06	07	10	11	12	13	14	15	16	17	L2	L2		
1746-IB16, IN16, ITB16	0	1	2	3	4	5	6	7	8	9	10	11	12	13	14	15	COM	COM		
	00	01	02	03	04	05	06	07	10	11	12	13	14	15	16	17	COM	COM		
1746-IV16, ITV16	0	1	2	3	4	5	6	7	8	9	10	11	12	13	14	15	+V	+V		
	00	01	02	03	04	05	06	07	10	11	12	13	14	15	16	17	+V	+V		
1746-OA16, OW16	L1-A	L1-A	0	1	2	3	4	5	6	7	8	9	10	11	12	13	14	15	L1-B	L1-B
	L1-A	L1-A	00	01	02	03	04	05	06	07	10	11	12	13	14	15	16	17	L1-B	L1-B
1746-IG16, OB16, OBP16, OG16, OV16, OVP16	+V	+V	0	1	2	3	4	5	6	7	8	9	10	11	12	13	14	15	COM	COM
	+V	+V	00	01	02	03	04	05	06	07	10	11	12	13	14	15	16	17	COM	COM
1746-OW16	+V1	+V1	0	1	2	3	4	5	6	7	8	9	10	11	12	13	14	15	+V2	+V2
	+V1	+V1	00	01	02	03	04	05	06	07	10	11	12	13	14	15	16	17	+V2	+V2
1746-OX8	L1/+	0	L1/+	1	L1/+	2	L1/+	3	4	L1/+	5	L1/+	6	L1/+	7	L1/+				
1771-IAD, IND	L1/+	00	01	02	03	04	05	06	07	10	11	12	13	14	15	16	17	L2/-		
1771-IBD, ICD		00	01	02	03	04	05	06	07	10	11	12	13	14	15	16	17	COM		
1771-OAD, OND	L1	L1	00	01	02	03	04	05	06	07	10	11	12	13	14	15	16	17	L1	L2
1771-IGD, OBD, OGD	+V	+V	00	01	02	03	04	05	06	07	10	11	12	13	14	15	16	17	+V	COM
NUMERIC	1	2	3	4	5	6	7	8	9	10	11	12	13	14	15	16	17	18	19	20
LED LABEL		00	01	02	03	04	05	06	07	10	11	12	13	14	15	16	17			
43006-253-01 (D)																				

Adhesive Label Card for Catalog Numbers 1492-IFM40F, -IFM40D24

I/O CAT. NO.	MODULE LABEL	LEVEL
1746-IB32	CM3 CM3 16 17 18 19 20 21 22 23 24 25 26 27 28 29 30 31 CM4 CM4	Upper
	CM1 CM1 0 1 2 3 4 5 6 7 8 9 10 11 12 13 14 15 CM2 CM2	Lower
	CM3 CM3 00 01 02 03 04 05 06 07 10 11 12 13 14 15 16 17 CM4 CM4	Upper
	CM1 CM1 00 01 02 03 04 05 06 07 10 11 12 13 14 15 16 17 CM2 CM2	Lower
1746-IV32	+V3 +V3 16 17 18 19 20 21 22 23 24 25 26 27 28 29 30 31 +V4 +V4	Upper
	+V1 +V1 0 1 2 3 4 5 6 7 8 9 10 11 12 13 14 15 +V2 +V2	Lower
	+V3 +V3 00 01 02 03 04 05 06 07 10 11 12 13 14 15 16 17 +V4 +V4	Upper
	+V1 +V1 00 01 02 03 04 05 06 07 10 11 12 13 14 15 16 17 +V2 +V2	Lower
1746-OB32, OV32	+V2 +V2 16 17 18 19 20 21 22 23 24 25 26 27 28 29 30 31 CM2 CM2	Upper
	+V1 +V1 0 1 2 3 4 5 6 7 8 9 10 11 12 13 14 15 CM1 CM1	Lower
	+V2 +V2 00 01 02 03 04 05 06 07 10 11 12 13 14 15 16 17 CM2 CM2	Upper
	+V1 +V1 00 01 02 03 04 05 06 07 10 11 12 13 14 15 16 17 CM1 CM1	Lower
1771-IAN	L2-C L2-C 00 01 02 03 04 05 06 07 10 11 12 13 14 15 16 17 L2-D L2-D	Upper
	L2-A L2-A 00 01 02 03 04 05 06 07 10 11 12 13 14 15 16 17 L2-B L2-B	Lower
1771-IBN	CM2 CM2 00 01 02 03 04 05 06 07 10 11 12 13 14 15 16 17 CM3 CM3	Upper
	CM0 CM0 00 01 02 03 04 05 06 07 10 11 12 13 14 15 16 17 CM1 CM1	Lower
1771-ID16, IQ16	00 01 02 03 04 05 06 07 10 11 12 13 14 15 16 17	Upper
	COM COM COM COM COM COM COM COM COM COM COM COM COM COM COM COM	Lower
	L2 L2 L2 L2 L2 L2 L2 L2 L2 L2 L2 L2 L2 L2 L2	Lower
1771-IVN	+V2 +V2 00 01 02 03 04 05 06 07 10 11 12 13 14 15 16 17 +V3 +V3	Upper
	+V0 +V0 00 01 02 03 04 05 06 07 10 11 12 13 14 15 16 17 +V1 +V1	Lower
1771-OAN	L1-C L1-D 00 01 02 03 04 05 06 07 10 11 12 13 14 15 16 17	Upper
	L1-A L1-B 00 01 02 03 04 05 06 07 10 11 12 13 14 15 16 17	Lower
1771-OBN, OVN	+V2 +V3 00 01 02 03 04 05 06 07 10 11 12 13 14 15 16 17 CM2 CM3	Upper
	+V0 +V1 00 01 02 03 04 05 06 07 10 11 12 13 14 15 16 17 CM0 CM1	Lower
1771-OD16, ODD	00 01 02 03 04 05 06 07 10 11 12 13 14 15 16 17	Upper
	L1 L1 L1 L1 L1 L1 L1 L1 L1 L1 L1 L1 L1 L1 L1	Lower
1771-OQ16	00 01 02 03 04 05 06 07 10 11 12 13 14 15 16 17	Upper
	+V +V +V +V +V +V +V +V +V +V +V +V +V +V +V	Lower
1771-OW16 (N.O.) ≠ (N.C.)	11= COM 12≠ 12= COM 13≠ 13= COM 14≠ 14= COM 15≠ 15= COM 16≠ 16= COM 17≠ 17= COM	Upper
	00= COM 01= COM 02= COM 03= COM 04= COM 05= COM 06= COM 07= COM 10≠ 10= COM 11≠	Lower
1771-OWN, OWNA	CM2 CM3 00 01 02 03 04 05 06 07 10 11 12 13 14 15 16 17	Upper
	CM0 CM1 00 01 02 03 04 05 06 07 10 11 12 13 14 15 16 17	Lower
NUMERIC	1 2 3 4 5 6 7 8 9 10 11 12 13 14 15 16 17 18 19 20	
	21 22 23 24 25 26 27 28 29 30 31 32 33 34 35 36 37 38 39 40	
	1 3 5 7 9 11 13 15 17 19 21 23 25 27 29 31 33 35 37 39	
	2 4 6 8 10 12 14 16 18 20 22 24 26 28 30 32 34 36 38 40	
LED LABELS	00 01 02 03 04 05 06 07 10 11 12 13 14 15 16 17	
	00 01 02 03 04 05 06 07 10 11 12 13 14 15 16 17	
43006-253-02 (E)		

Adhesive Label Card for Catalog Number 1492-IFM20F-F24A-2

- The 1492-IFM20F-F24A-2 comes with the label shown on page 12-130.
- For the upper row of terminals, use the standard “Upper Level” decimal or octal label per the I/O Module.
- For the lower row of terminals, use the “Upper Level” label from the output module described in the table below.

For the Lower Row of Terminals in This Application			Use the “Upper Level” Label From This Output Module
I/O Module	Voltage	Number System	
1746-IB16, -ITB16	DC	Decimal	1746-OW16 Decimal
1746-IB16, -ITB16	DC	Octal	1746-OW16 Octal
1746-IN16	AC	Decimal	1746-OA16, -OW16 Decimal
1746-IN16	AC	Octal	1746-OA16, -OW16 Octal
1746-IN16	DC	Decimal	1746-OW16 Decimal
1746-IN16	DC	Octal	1746-OW16 Octal
1746-OV16, -OVP16	DC	Decimal	1746-OW16 Decimal
1746-OV16, -OVP16	DC	Octal	1746-OW16 Octal
1771-IBD, -ICD	DC	Octal	1746-OW16 Octal
1771-IND	AC	Octal	1746-OA16, -OW16 Octal
1771-IND	DC	Octal	1746-OW16 Octal

Bulletin 1492
Programmable Controller Wiring Systems
Marking Systems

Adhesive Label Card for Catalog Numbers 1492-IFM20F-3, -IFM20D24-3, -IFM40F-3, and -IFM40D24-3

I/O CAT. NO.	MODULE LABEL																		
1746-IB16, ITB16, IN16 1771-IBD, ICD	0	1	2	3	4	5	6	7	8	9	10	11	12	13	14	15	Upper		
	00	01	02	03	04	05	06	07	10	11	12	13	14	15	16	17	Upper		
	COM																Middle		
	+V																Lower		
1746-IV16, ITV16	0	1	2	3	4	5	6	7	8	9	10	11	12	13	14	15	Upper		
	00	01	02	03	04	05	06	07	10	11	12	13	14	15	16	17	Upper		
	+V																Middle		
	COM																Lower		
1746-IB32, 1771-IBN	0	1	2	3	4	5	6	7	8	9	10	11	12	13	14	15	Upper Lf		
	00	01	02	03	04	05	06	07	10	11	12	13	14	15	16	17	Upper Lf		
	COM																Middle Lf		
	+V																Lower Lf		
	16	17	18	19	20	21	22	23	24	25	26	27	28	29	30	31	Upper Rt		
	00	01	02	03	04	05	06	07	10	11	12	13	14	15	16	17	Upper Rt		
	COM																Middle Rt		
	+V																Lower Rt		
1746-IV32, 1771-IVN	0	1	2	3	4	5	6	7	8	9	10	11	12	13	14	15	Upper Lf		
	00	01	02	03	04	05	06	07	10	11	12	13	14	15	16	17	Upper Lf		
	+V																Middle Lf		
	COM																Lower Lf		
	16	17	18	19	20	21	22	23	24	25	26	27	28	29	30	31	Upper Rt		
	00	01	02	03	04	05	06	07	10	11	12	13	14	15	16	17	Upper Rt		
	+V																Middle Rt		
	COM																Lower Rt		
NUMERIC	1	2	3	4	5	6	7	8	9	10	11	12	13	14	15	16			
	17	18	19	20	21	22	23	24	25	26	27	28	29	30	31	32	33	34	
	35	36	37	38	39	40	41	42	43	44	45	46	47	48	49	50	51	52	
	1	2	3	4	5	6	7	8	9	10	11	12	13	14	15	16			
	17	18	19	20	21	22	23	24	25	26	27	28	29	30	31	32	33	34	
	35	36	37	38	39	40	41	42	43	44	45	46	47	48	49	50	51	52	
	53	54	55	56	57	58	59	60	61	62	63	64	65	66	67	68			
	69	70	71	72	73	74	75	76	77	78	79	80	81	82	83	84	85	86	
	87	88	89	90	91	92	93	94	95	96	97	98	99	100	101	102	103	104	
	17	18	19	20	21	22	23	24	25	26	27	28	29	30	31	32			
	33	34	35	36	37	38	39	40	41	42	43	44	45	46	47	48	49	50	
	51	52	53	54	55	56	57	58	59	60	61	62	63	64	65	66	67	68	
LED LABELS	00	01	02	03	04	05	06	07	10	11	12	13	14	15	16	17			
	00	01	02	03	04	05	06	07	10	11	12	13	14	15	16	17			
43006-253-04 (A)																			

Part 1 of Adhesive Label Card for Catalog Numbers 1492-IFM40F-2, -IFM40D24-2, -IFM40D24A-2, -IFM40D120-2, -IFM40D120A-2, -IFM40F-F-2, -IFM40F-F24-2, and -IFM40F-F120-2

I/O CAT. NO.	MODULE LABEL																																LEVEL	
1746-IB32	CM1 CM1 0 1 2 3 4 5 6 7 8 9 10 11 12 13 14 15 CM2 CM2 CM3 CM3 16 17 18 19 20 21 22 23 24 25 26 27 28 29 30 31 CM4 CM4																																	Upper
	CM1 CM1 00 01 02 03 04 05 06 07 10 11 12 13 14 15 16 17 CM2 CM2 CM3 CM3 00 01 02 03 04 05 06 07 10 11 12 13 14 15 16 17 CM4 CM4																																	Upper
	-----+V1----- -----+V2----- -----+V3----- -----+V4-----																																	Lower
1746-IV32	+V1 +V1 0 1 2 3 4 5 6 7 8 9 10 11 12 13 14 15 +V2 +V2 +V3 +V3 16 17 18 19 20 21 22 23 24 25 26 27 28 29 30 31 +V4 +V4																																	Upper
	+V1 +V1 00 01 02 03 04 05 06 07 10 11 12 13 14 15 16 17 +V2 +V2 +V3 +V3 00 01 02 03 04 05 06 07 10 11 12 13 14 15 16 17 +V4 +V4																																	Upper
	-----CM1----- -----CM2----- -----CM3----- -----CM4-----																																	Lower
1746-OB32	+V1 +V1 0 1 2 3 4 5 6 7 8 9 10 11 12 13 14 15 CM1 CM1 +V2 +V2 16 17 18 19 20 21 22 23 24 25 26 27 28 29 30 31 CM2 CM2																																	Upper
	+V1 +V1 00 01 02 03 04 05 06 07 10 11 12 13 14 15 16 17 CM1 CM1 +V2 +V2 00 01 02 03 04 05 06 07 10 11 12 13 14 15 16 17 CM2 CM2																																	Upper
	-----CM1----- -----CM1----- -----CM2----- -----CM2-----																																	Lower
1746-OV32	+V1 +V1 0 1 2 3 4 5 6 7 8 9 10 11 12 13 14 15 CM1 CM1 +V2 +V2 16 17 18 19 20 21 22 23 24 25 26 27 28 29 30 31 CM2 CM2																																	Upper
	+V1 +V1 00 01 02 03 04 05 06 07 10 11 12 13 14 15 16 17 CM1 CM1 +V2 +V2 00 01 02 03 04 05 06 07 10 11 12 13 14 15 16 17 CM2 CM2																																	Upper
	-----+V1----- -----+V1----- -----+V2----- -----+V2-----																																	Lower
1771-IAN	L2-A L2-A 00 01 02 03 04 05 06 07 10 11 12 13 14 15 16 17 L2-B L2-B L2-C L2-C 00 01 02 03 04 05 06 07 10 11 12 13 14 15 16 17 L2-D L2-D																																	Upper
	-----L1-A----- -----L1-B----- -----L1-C----- -----L1-D-----																																	Lower
1771-IBN	CM0 CM0 00 01 02 03 04 05 06 07 10 11 12 13 14 15 16 17 CM1 CM1 CM2 CM2 00 01 02 03 04 05 06 07 10 11 12 13 14 15 16 17 CM3 CM3																																	Upper
	-----+V0----- -----+V1----- -----+V2----- -----+V3-----																																	Lower
1771-IVN	+V0 +V0 00 01 02 03 04 05 06 07 10 11 12 13 14 15 16 17 +V1 +V1 +V2 +V2 00 01 02 03 04 05 06 07 10 11 12 13 14 15 16 17 +V3 +V3																																	Upper
	-----CM0----- -----CM1----- -----CM2----- -----CM3-----																																	Lower
1771-OAN	L1-A L1-B 00 01 02 03 04 05 06 07 10 11 12 13 14 15 16 17 L1-C L1-D 00 01 02 03 04 05 06 07 10 11 12 13 14 15 16 17																																	Upper
	-----L2-A----- -----L2-B----- -----L2-C----- -----L2-D-----																																	Lower
1771-OBN	+V0 +V1 00 01 02 03 04 05 06 07 10 11 12 13 14 15 16 17 CM0 CM1 +V2 +V3 00 01 02 03 04 05 06 07 10 11 12 13 14 15 16 17 CM2 CM3																																	Upper
	-----CM0----- -----CM1----- -----CM2----- -----CM3-----																																	Lower
1771-OVN	+V0 +V1 00 01 02 03 04 05 06 07 10 11 12 13 14 15 16 17 CM0 CM1 +V2 +V3 00 01 02 03 04 05 06 07 10 11 12 13 14 15 16 17 CM2 CM3																																	Upper
	-----+V0----- -----+V1----- -----+V2----- -----+V3-----																																	Lower
43006-253-05 (B)																																		

Part 2 of Adhesive Label Card for Catalog Numbers 1492-IFM40F-2, -IFM40D24-2, -IFM40D24A-2, -IFM40D120-2, -IFM40D120A-2, -IFM40F-F-2, -IFM40F-F24-2, and -IFM40F-F120-2

1771-OW16 = (N.O.) ≠ (N.C.)	00= COM 01= COM 02= COM 03= COM 04= COM 05= COM 06= COM 07= COM 10≠ 10= COM 11≠ 11= COM 12≠ 12= COM 13≠ 13= COM 14≠ 14= COM 15≠ 15= COM 16≠ 16= COM 17≠ 17= COM																																		Upper																																		
	+V										COM										+V										COM										Lower																												
	L1										L2										L1										L2										Lower																												
	+V										+V										+V										+V										Lower																												
	COM										COM										COM										COM										Lower																												
	L1										L1										L1										L1										Lower																												
	L2										L2										L2										L2										Lower																												
1771-OWN, OWNA	CM0 CM1 00 01 02 03 04 05 06 07 10 11 12 13 14 15 16 17																	CM2 CM3 00 01 02 03 04 05 06 07 10 11 12 13 14 15 16 17																	Upper																																		
	+V0																	+V1																	+V2																	+V3																	Lower
	CM0																	CM1																	CM2																	CM3																	Lower
	L1-A																	L1-B																	L1-C																	L1-D																	Lower
	L2-A																	L2-B																	L2-C																	L2-D																	Lower
NUMERIC	1 2 3 4 5 6 7 8 9 10 11 12 13 14 15 16 17 18 19 20 21 22 23 24 25 26 27 28 29 30 31 32 33 34 35 36 37 38 39 40																																																																				
	41 42 43 44 45 46 47 48 49 50 51 52 53 54 55 56 57 58 59 60 61 62 63 64 65 66 67 68 69 70 71 72 73 74 75 76 77 78 79 80																																																																				
	1 3 5 7 9 11 13 15 17 19 21 23 25 27 29 31 33 35 37 39 41 43 45 47 49 51 53 55 57 59 61 63 65 67 69 71 73 75 77 79																																																																				
	2 4 6 8 10 12 14 16 18 20 22 24 26 28 30 32 34 36 38 40 42 44 46 48 50 52 54 56 58 60 62 64 66 68 70 72 74 76 78 80																																																																				
LED LABEL	00 01 02 03 04 05 06 07 10 11 12 13 14 15 16 17																	00 01 02 03 04 05 06 07 10 11 12 13 14 15 16 17																																																			
FUSE LABEL	00 01 02 03 04 05 06 07 10 11 12 13 14 15 16 17																	00 01 02 03 04 05 06 07 10 11 12 13 14 15 16 17																																																			
43006-253-06 (B)																																																																					

Adhesive Label Card for Catalog Numbers 1492-IFM20FN, -IFM20D24N, and -IFM20D120N

I/O CAT. NO.	MODULE LABEL										LEVEL
1746-IA16, IN16	8	9	10	11	12	13	14	15	L2		Upper
	0	1	2	3	4	5	6	7	L2		Lower
	10	11	12	13	14	15	16	17	L2		Upper
	00	01	02	03	04	05	06	07	L2		Lower
1746-IB16, IC16, IH16, IN16, ITB16	8	9	10	11	12	13	14	15	COM		Upper
	0	1	2	3	4	5	6	7	COM		Lower
	10	11	12	13	14	15	16	17	COM		Upper
	00	01	02	03	04	05	06	07	COM		Lower
1746-IG16, OB16, OBP16, OG16, OV16, OVP16	+V	8	9	10	11	12	13	14	15	COM	Upper
	+V	0	1	2	3	4	5	6	7	COM	Lower
	+V	10	11	12	13	14	15	16	17	COM	Upper
	+V	00	01	02	03	04	05	06	07	COM	Lower
1746-IV16, ITV16	8	9	10	11	12	13	14	15	+V		Upper
	0	1	2	3	4	5	6	7	+V		Lower
	10	11	12	13	14	15	16	17	+V		Upper
	00	01	02	03	04	05	06	07	+V		Lower
1746-OA16, OW16, 1771-OAD, OND	L1	8	9	10	11	12	13	14	15	L2	Upper
	L1	0	1	2	3	4	5	6	7	L1	Lower
	L1	10	11	12	13	14	15	16	17	L2	Upper
	L1	00	01	02	03	04	05	06	07	L1	Lower
1746-OW16	+V	8	9	10	11	12	13	14	15	COM	Upper
	+V	0	1	2	3	4	5	6	7	+V	Lower
	+V	10	11	12	13	14	15	16	17	COM	Upper
	+V	00	01	02	03	04	05	06	07	+V	Lower
1746-OX8	4	4L1	5	5L1	6	6L1	7	7L1			Upper
	0L1	0	1L1	1	2L1	2	3L1	3			Lower
	4	+V4	5	+V5	6	+V6	7	+V7			Upper
	+V0	0	+V1	1	+V2	2	+V3	3			Lower
1771-IAD, IND	10	11	12	13	14	15	16	17	L2		Upper
	L1	00	01	02	03	04	05	06	07		Lower
	10	11	12	13	14	15	16	17	COM		Upper
	+V	00	01	02	03	04	05	06	07		Lower
1771-IBD, ICD	10	11	12	13	14	15	16	17	COM		Upper
	00	01	02	03	04	05	06	07			Lower
1771-IGD, OBD, OGD	+V	10	11	12	13	14	15	16	17	COM	Upper
	+V	00	01	02	03	04	05	06	07	+V	Lower
NUMERIC	1	2	3	4	5	6	7	8	9	10	
	11	12	13	14	15	16	17	18	19	20	
	1	3	5	7	9	11	13	15	17	19	
	2	4	6	8	10	12	14	16	18	20	
LED LABEL	10	11	12	13	14	15	16	17			
	00	01	02	03	04	05	06	07			
44006-274-02 (C)											

Bulletin 1492
Programmable Controller Wiring Systems
Marking Systems

Adhesive Label Card for Catalog Number 1492-AIFM4-3

I/O CAT. NO.	MODULE LABEL								LEVEL	
1746-NI4	2+	2-	C	SH	3+	3-	C	SH	UPPER	
	0+	0-	C	SH	1+	1-	C	SH	LOWER	
1746-NIO4I, -NIO4V,-FIO4I, -FIO4V	O/O	C	SH	O/I	C	SH			UPPER	
	0+	0-	C	SH	1+	1-	C	SH	LOWER	
1746-NO4I,-NO4V,	2	C	+V	SH	3	C	-V	SH	UPPER	
	0	C	+V	SH	1	C	-V	SH	LOWER	
	2	C			SH	3	C	SH	UPPER	
	0	C			SH	1	C	SH	LOWER	
1771-OFE	3+	3-			SH	4+	4-			UPPER
	1+	1-			SH	2+	2-			LOWER
NUMERIC	1	2	3	4	5	6	7	8		
	9	10	11	12	13	14	15	16		
	1	3	5	7	9	11	13	15		
	2	4	6	8	10	12	14	16		
45006-034-01 (A)										

Bulletin 1492
Programmable Controller Wiring Systems
Marking Systems

Adhesive Label Card for Catalog Number 1492-AIFM6S-3

I/O CAT. NO.	MODULE LABEL												LEVEL
1756-IT6I, -OF6CI, -OF6VI, -IF6I	0	R0	1	R1	2	R2	3	R3	4	R4	5	R5	UPPER
	SH		SH		SH		SH		SH		SH		LOWER
1756-IR6I	A0	R/C0	A1	R/C1	A2	R/C2	A3	R/C3	A4	R/C4	A5	R/C5	UPPER
	B0	SH	B1	SH	B2	SH	B3	SH	B4	SH	B5	SH	LOWER
1746-NR4	I0	S0	I1	S1	I2	S2	I3	S3					UPPER
	R0	SH	R1	SH	R2	SH	R3	SH					LOWER
1771-IR	A1	C1	A2	C2	A3	C3	A4	C4	A5	C5	A6	C6	UPPER
	B1	SH	B2	SH	B3	SH	B4	SH	B5	SH	B6	SH	LOWER
NUMERIC	1	2	3	4	5	6	7	8	9	10	11	12	
	13	14	15	16	17	18	19	20	21	22	23	24	
	1	3	5	7	9	11	13	15	17	19	21	23	
	2	4	6	8	10	12	14	16	18	20	22	24	
45006-021-01 (B)													

Bulletin 1492
Programmable Controller Wiring Systems
Marking Systems

Adhesive Label Card for Catalog Numbers 1492-AIFM16-F-3 and -AIFM8-F-5

I/O CAT. NO.	MODULE LABEL																LEVEL
1771-IFE SINGLE ENDED	V1 V2 V3 V4 V5 V6 V7 V8 V9 V10 V11 V12 V13 V14 V15 V16	Upper															
	+V 1 2 3 4 5 6 7 8 9 10 11 12 13 14 15 16 COM	Middle															
	SHIELD	Lower															
1771-IFE DIFFERENTIAL	1+ 1- 2+ 2- 3+ 3- 4+ 4- 5+ 5- 6+ 6- 7+ 7- 8+ 8-	Upper															
	+V V1 V2 V3 V4 V5 V6 V7 V8 V COM	Middle															
	SHIELD	Lower															
1746-NIB	0+ 0- 1+ 1- 2+ 2- 3+ 3- 4+ 4- 5+ 5- 6+ 6- 7+ 7-	Upper															
	+V V0 V1 V2 V3 V4 V5 V6 V7 V COM	Middle															
	SHIELD	Lower															
LED LABEL	0 1 2 3 4 5 6 7																
NUMERIC	1 2 3 4 5 6 7 8 9 10 11 12 13 14 15 16																
	17 18 19 20 21 22 23 24 25 26 27 28 29 30 31 32 33 34																
	35 36 37 38 39 40 41 42 43 44 45 46 47 48 49 50 51 52																
44006-274-01 (D)																	

Adhesive Label Card for Catalog Number 1492-AIFM16-F-5

I/O CAT. NO.	MODULE LABEL	LEVEL
1771-IFE SINGLE ENDED	1 2 3 4 5 6 7 8 _____ MODULE COM _____	UPPER LF
	+V V1 V2 V3 V4 V5 V6 V7 V8 _____ V COM _____	MIDDLE LF
	_____ SHIELD _____ 1J-1 1J-2	LOWER LF
	9 10 11 12 13 14 15 16 _____ MODULE COM _____	UPPER RT
	+V V9 V10 V11 V12 V13 V14 V15 V16 _____ V COM _____	MIDDLE RT
	_____ SHIELD _____	LOWER RT
NUMERIC	1 2 3 4 5 6 7 8 9 10 11 12 13 14 15 16 TB1	LEFT RIGHT
	17 18 19 20 21 22 23 24 25 26 27 28 29 30 31 32 33 34	
	35 36 37 38 39 40 41 42 43 44 45 46 47 48 49 50 51 52	
	1 2 3 4 5 6 7 8 9 10 11 12 13 14 15 16 TB2	
	17 18 19 20 21 22 23 24 25 26 27 28 29 30 31 32 33 34	
	35 36 37 38 39 40 41 42 43 44 45 46 47 48 49 50 51 52	
	53 54 55 56 57 58 59 60 61 62 63 64 65 66 67 68	
	69 70 71 72 73 74 75 76 77 78 79 80 81 82 83 84 85 86	
	87 88 89 90 91 92 93 94 95 96 97 98 99 100 101 102 103 104	
	17 18 19 20 21 22 23 24 25 26 27 28 29 30 31 32	
33 34 35 36 37 38 39 40 41 42 43 44 45 46 47 48 49 50		
51 52 53 54 55 56 57 58 59 60 61 62 63 64 65 66 67 68		
LED LABEL	0 1 2 3 4 5 6 7	LEFT
	8 9 10 11 12 13 14 15	RIGHT
45006-018-01 (A)		

Accessories

Application of Accessories

The following pages use photographs and dimensions to describe accessories that Allen-Bradley offers for its 1492 Terminal Block line. The accessory section is set up as follows:

Mounting Rails

Mounting rails allow many blocks to be fastened in a panel with only a few screws to anchor the rail to the panel. Mounting rails allow easy installation and removal of a block in a row

End Anchors/End Retainers

End anchors and End retainers mount at both ends of a group of terminal blocks to add rigidity to the terminal assembly and prevent sliding along the rail

End Barriers

End barriers are required to provide the necessary insulation for the last terminal block in a group

Partition Plates

Partition plates allow visual and electrical separation of terminal groups and provide the necessary electrical spacing between adjacent insulated jumpers or between exposed ends of cut jumpers

Separation Plates

Separation plates consist of flexible thermoplastic material and are used between terminal blocks to isolate adjacent center jumpers both visually and electrically. Separation plates must be used between adjacent center jumpers to obtain full rated isolation voltage

Terminal Covers

Terminal covers are for use with QuickClamp™ terminal blocks and are designed to act as end barriers and/or partition plates when special tabs are snapped apart

Fanning Strips

Fanning strips, used with the 1492–CA1, –CAM1, –CA2, –CAM2 terminal blocks, keep wires in an orderly row and allow easy disconnect and reconnect of multiple adjacent wires

Side Jumpers

Side jumpers use the terminal block wire openings. Multipole jumpers can be cut into a smaller number of poles. Two pole jumpers are also available for some blocks. All jumpers except the 1492–N21 carry 100% of rated terminal block current. The 1492–N21 carries 100A

The back of IEC style jumpers are plastic insulated. An adjacent partition plate provides the necessary electrical spacings between adjacent jumpers or between exposed ends of cut jumpers

Center Jumpers — IEC Only

These center jumpers use the threaded holes between the terminal block clamping screws to interconnect circuits and do not reduce the wiring capacity of the blocks. The center jumper assembly is inserted into the terminal block housing and the screws tightened

If center jumpers are used adjacent to each other, the appropriate separation plate or partition plate must be used to obtain full rated isolation voltage. Center jumpers carry 100% of rated current

Center Jumpers — QuickClamp™ Only

These center jumpers are insulated and are available in 10 poles. They mount into the QuickClamp™ terminal blocks without screws, and can be connected together with a specially designed center jumper link

Center Jumper Covers

Center jumper covers can be used to enclose the center jumper channel, as well as an extruded marking surface for circuit identification

Test Plugs and Sockets — IEC Only

The sockets fit into the center bridge screw hole and allow easy connection of test plugs for circuit testing and troubleshooting

Marking Systems

Various marking systems are available to simplify circuit identification. NEMA blocks come with a painted marking surface

IEC blocks use snap-in markers. Markers are available in blank form for hand writing, preprinted in ascending number format, or custom printed for unique requirements. Extended marking strips and adhesive labels are available for long circuit identifications. A group marking carrier for easy group terminal block identification is also available. Marking rods can be used with QuickClamp™ style terminal blocks to simplify mass marking solutions

Insulation Stops — QuickClamp™ Only

Protective insulation stops prevent the insulation on conductors from being introduced into clamp and current bar area







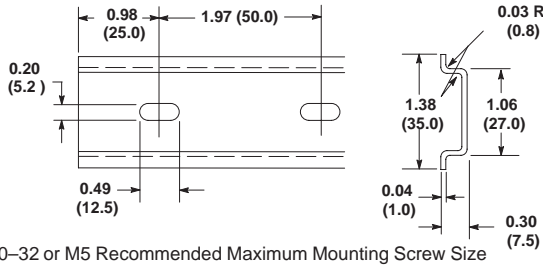

Warning Plates

Warning plates provide visual identification for high voltage applications

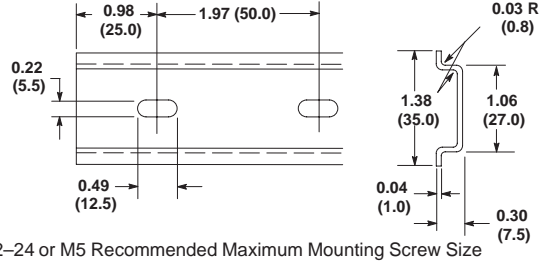
Agency Approvals

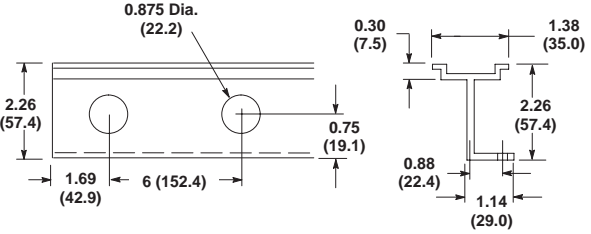
In general, accessories for terminal blocks are not eligible for recognition by UL, CSA, or other third party approval agencies. The suitability of the installation must be judged in the end use application due to the wide variety of possible uses. However, accessories are designed to meet, and are tested to, the terminal block assembly requirements such as electrical spacings, etc.

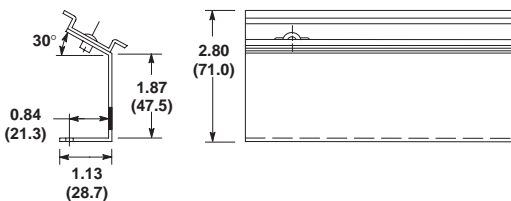

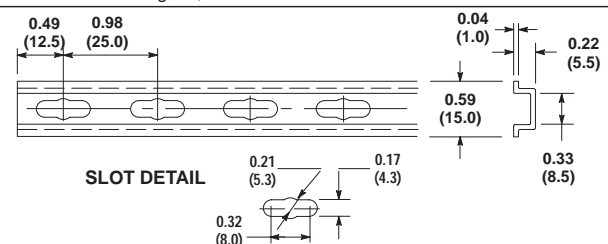



DIN MOUNTING RAILS

Item	Description	Pcs./Pkg.	Dimensions ^①
 <p>199-DR1</p>	<p>Symmetrical Rail 35 mm x 7.5 mm 3.28' (1m) long. Zinc Plated, Yellow Chromated Steel EN50022</p> <p>DIN #3</p>	10	 <p>#10-32 or M5 Recommended Maximum Mounting Screw Size</p>
 <p>1492-DR5</p>	<p>Symmetrical Rail 35 mm x 7.5 mm 3.28' (1m) long. Copper Free Aluminum EN50022</p> <p>DIN #3</p>	10	 <p>#12-24 or M5 Recommended Maximum Mounting Screw Size</p>
 <p>1492-DR6^②</p>	<p>Symmetrical Rail 35 mm x 7.5 mm 2.26" (57.4 mm) high 3.28' (1m) long. Copper Free Aluminum</p> <p>DIN #3</p>	2	 <p>Wire insulator plug for wire access thru rail — use Heyco UB875</p>
 <p>1492-DR7^②</p>	<p>Symmetrical Rail 35 mm x 7.5 mm 2.80" (71.0 mm) high 3.28' (1m) long. Angled 30° Zinc Plated, Chromated Steel</p> <p>DIN #3</p>	2	 <p>For detail of mounting rail, see 199-DR1</p>
 <p>1492-DR3</p>	<p>Mini 15 mm x 5.5mm Rail 3.28' (1m) long. Zinc Plated, Yellow Chromated Steel EN50045</p> <p>DIN #2</p>	5	 <p>#8-32 or M4 Recommended Maximum Mounting Screw Size</p>

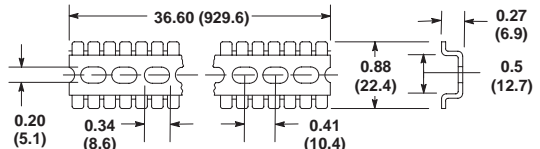
① Dimensions shown in inches (millimeters). Dimensions are not intended to be used for manufacturing purposes.

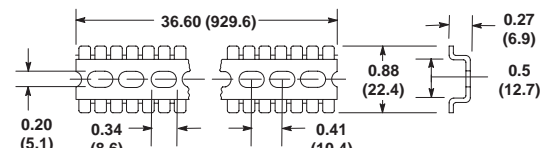
② 0.218" (5.5 mm) x 0.50" (12.7 mm) slotted mounting holes every 3" (76.2 mm) starting 1.69" (42.9 mm) from end.

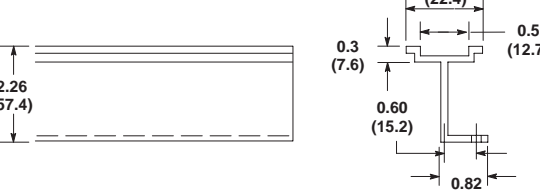
NEMA/EEMAC MOUNTING RAILS

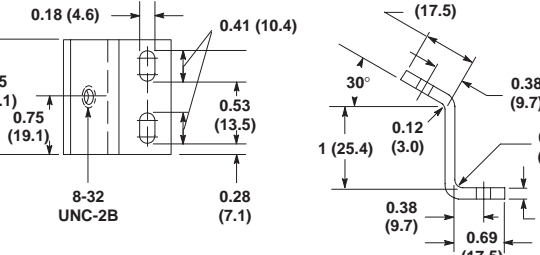
Item	Description	Pcs./Pkg.	Dimensions ^①
	Breakaway Mounting Rail 3' (.91m) long. Scored every 0.203" (5.2mm) so it will break off to the desired length.	20	 <p>#8-32 or M4 Recommended Mounting Screw Size</p>
	Rigid Mounting Rail 3' (.91m) long.	20	 <p>#8-32 or M4 Recommended Mounting Screw Size</p>
	2.26" (57.4 mm) High Rise Mounting Rail 3' (.91m) long. Aluminum.	2	
	Mounting Rail Standoff Brackets. Used with 1492-N22 Rigid Mounting Rail.	2	

① Dimensions shown in inches (millimeters). Dimensions are not intended to be used for manufacturing purposes.

② 0.19" (4.8 mm) x 0.4" (10.2 mm) slotted mounting holes every 3" (76.2 mm) starting 1.5" (38.1 mm) from end.

STACKING BRIDGE KITS





1492-N26

1492-N32

1492-N27

1492-N28

1492-N29

														
Description			Description			Description			Description			Description		
External Mounting Feet			Internal Mounting Feet			Side Plate Extensions			18" Bridge			12" Bridge		
Catalog No.	Pcs./ Pkg.	*	Catalog No.	Pcs./ Pkg.	*	Catalog No.	Pcs./ Pkg.	*	Catalog No.	Pcs./ Pkg.	*	Catalog No.	Pcs./ Pkg.	*
1492-N26	1 Kit		1492-N32	1 Kit		1492-N27	1 Kit		1492-N28	1		1492-N29	1	

Description — Stacking bridges are used with Style C, F and H rail mounted terminal blocks. They are designed to save panel space and increase terminal accessibility. Stacking bridge kits allow stacking of up to four terminal block strips. A stacking bridge consists of mounting feet, side plate extensions, and 12" or 18" bridges.

Note: Rigid mounting rail is attached to the bridge.) Five kits are available to custom build stacking bridges as listed in the above table.

IMPORTANT — Fuse blocks, disconnect blocks, large Style C terminal blocks (Catalog Number **1492-CE2**) and circuit breakers should only be mounted on the upper-most bridge of any assembly.

ORDERING EXAMPLE — A typical ordering example for a **Two Level 18" Stacking Bridge** is as follows:

One Catalog Number **492-N26** or **1492-N32** mounting foot kit.

One Catalog Number **1492-N27** side plate extension kit, and Two Catalog Number **1492-N28** 18" bridges.

Both 12" and 18" stacking bridges are built in this manner with up to four levels maximum.

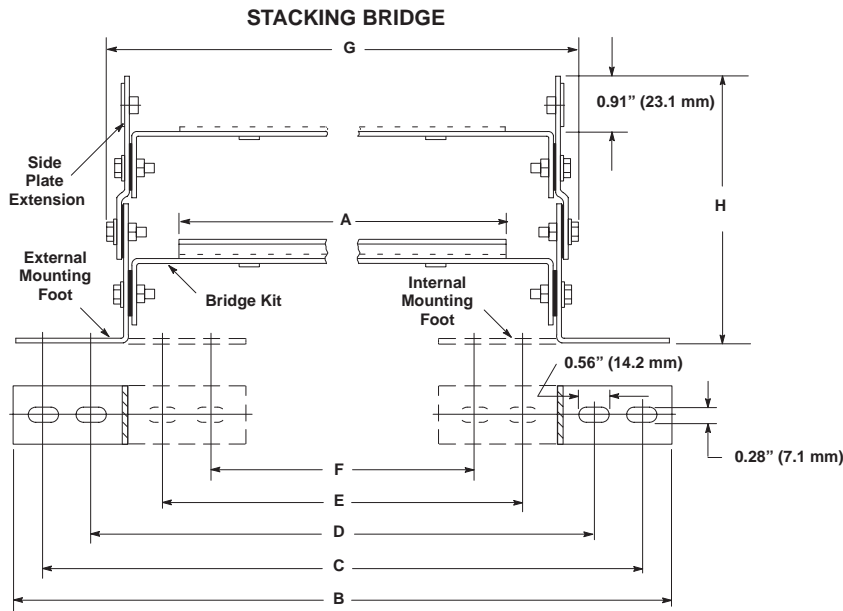

Dimensions In Inches (millimeters)											
Stacking Bridge Size	A	B	C	D	E	F	G	H			
								Number of Levels			
								1	2	3	4
12"	12.06 (306.3)	18.06 (458.7)	17 (431.8)	15.19 (385.8)	12.69 (322.3)	10.97 (278.6)	14.53 (369.1)	2.34 (59.5)	4.50 (114.3)	6.63 (168.4)	8.78 (223.0)
18"	18.63 (473.2)	24.06 (611.1)	23 (584.2)	21.19 (538.2)	18.69 (474.7)	16.97 (431.0)	20.53 (521.5)	2.34 (59.5)	4.50 (114.3)	6.63 (168.4)	8.78 (223.0)

END ANCHORS — IEC

1492-EA15

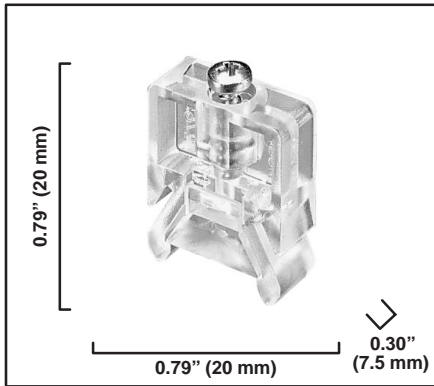

1492-EA35

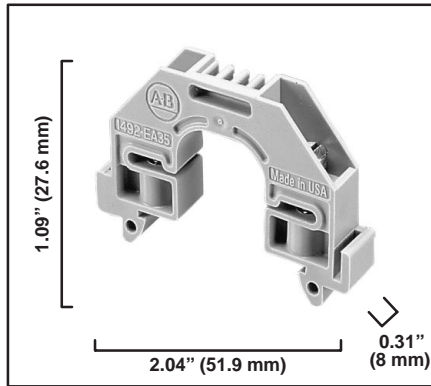

1492-EAH35

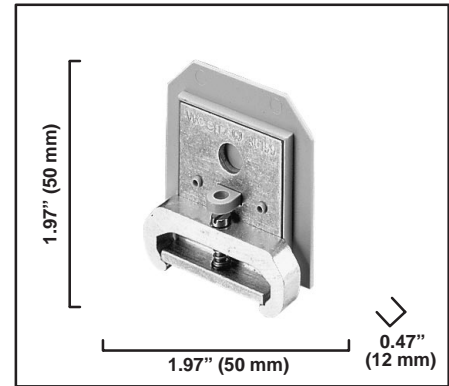

END ANCHORS — NEMA/EEMAC

1492-N2

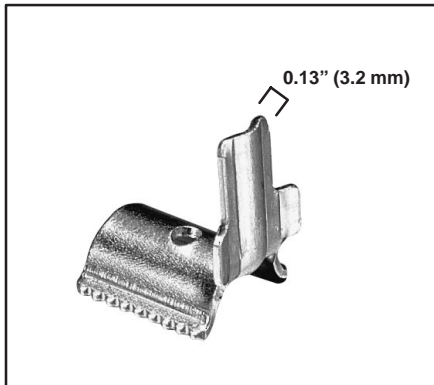

1492-N23

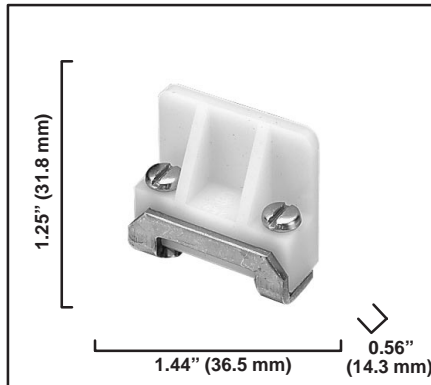

1492-N47

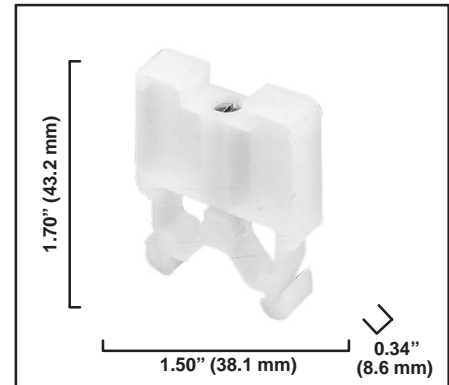

1492-15A, 1492-25A

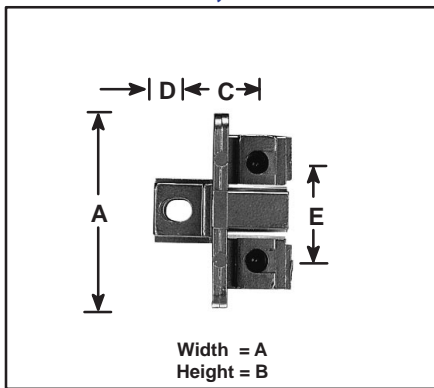

1492-15E, 1492-25E

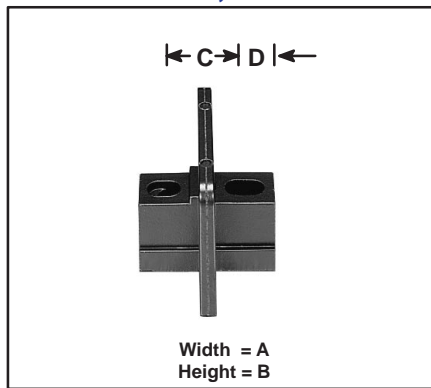

Catalog Number	A	B	C	D	E
1492-15A	1.5" (38.1 mm)	1.03" (26.2 mm)	0.594" (15.1 mm)	0.234" (5.9 mm)	0.75" (19.1 mm)
1492-15E	1.5" (38.1 mm)	1.03" (26.2 mm)	0.594" (15.1 mm)	0.234" (5.9 mm)	—
1492-25A	1.88" (47.8 mm)	1.19" (30.2 mm)	0.688" (17.5 mm)	0.203" (5.2 mm)	0.97" (24.6 mm)
1492-25E	1.88" (47.8 mm)	1.19" (30.2 mm)	0.688" (17.5 mm)	0.234" (5.9 mm)	—

END BARRIERS — IEC

**1492-EB3, 1492-EB3-Y,
 1492-EB10, 1492-EB10-Y,
 1492-EBM3, 1492-EBM4**

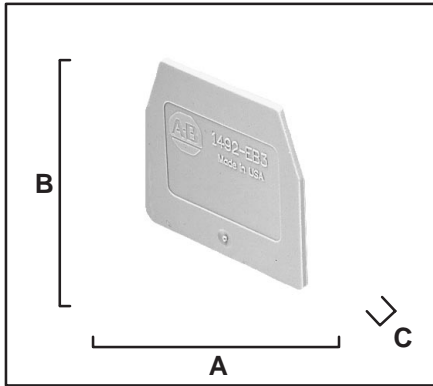

Catalog Number	A	B	C
1492-EB3	1.46"	1.38"	0.06"
1492-EB3-Y	(37 mm)	(35 mm)	(1.5 mm)
1492-EB10	1.77"	1.61"	0.06"
1492-EB10-Y	(45 mm)	(41 mm)	(1.5 mm)
1492-EBM3	1.10"	0.97"	0.06"
	(28 mm)	(24.6 mm)	(1.5 mm)
1492-EBM4	1.22"	1.09"	0.06"
	(31 mm)	(27.7 mm)	(1.5 mm)

**1492-EB16, 1492-EB35,
 1492-EBD4N**

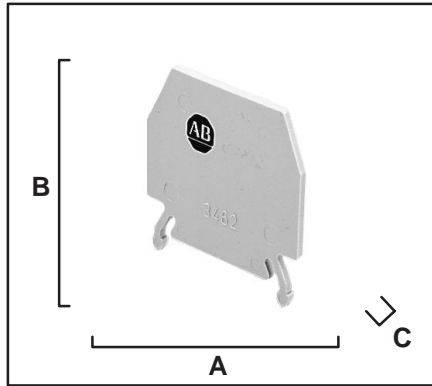

Catalog Number	A	B	C
1492-EB16	2.17"	2.15"	0.08"
	(55 mm)	(54.5 mm)	(2 mm)
1492-EB35	2.36"	2.80"	0.08"
	(60 mm)	(71 mm)	(2 mm)
1492-EBD4N	3.50"	1.97"	0.08"
	(89 mm)	(50 mm)	(2 mm)

1492-EBKD6

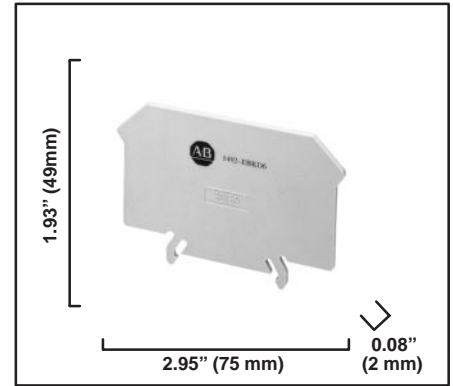

1492-EBMD1

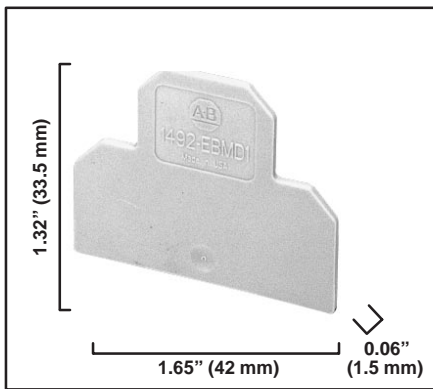

1492-EBD3

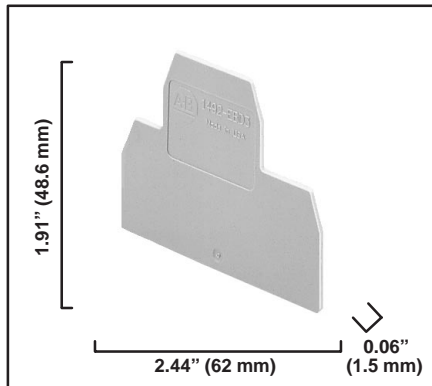

1492-EB3TW

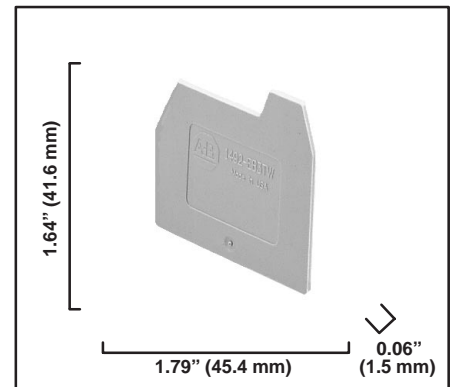

1492-EBKD3

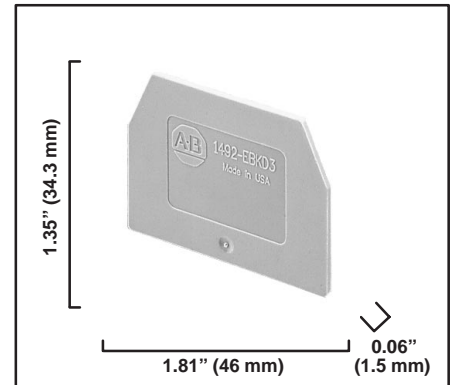

1492-EBTS3

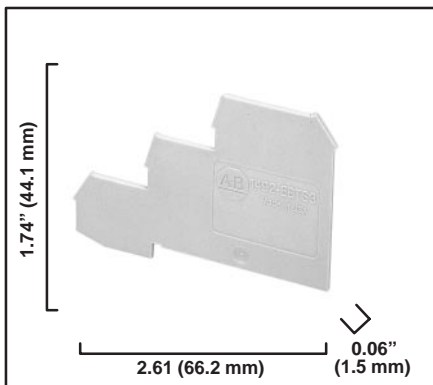

1492-EBTF3

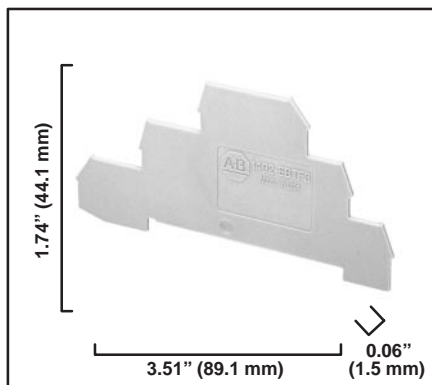

Note: Height dimension of products that mount on rail is from top of rail to top of end barrier.

END BARRIERS — IEC (Continued)

1492-EBD4P

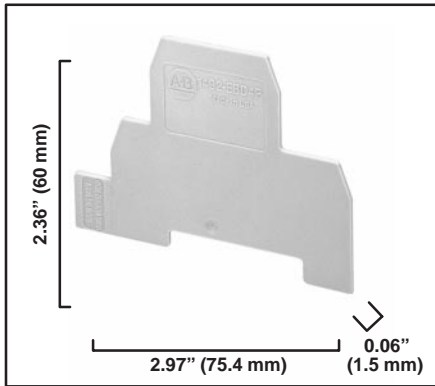

1492-EBD6

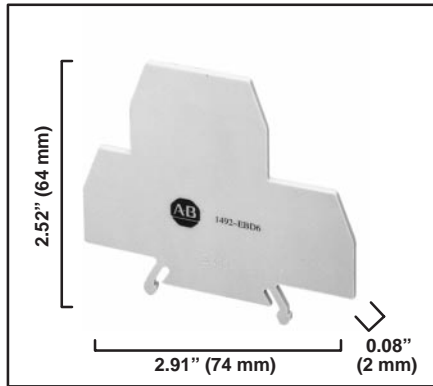

1492-EBR3

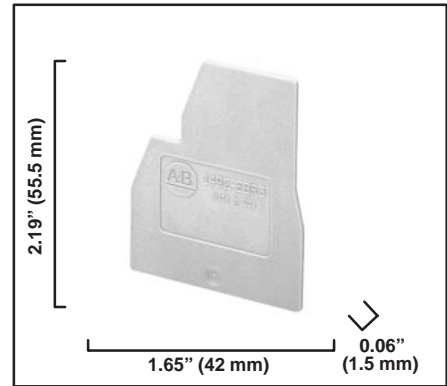

END BARRIERS — NEMA/EEMAC

1492-NM16, 1492-NM16BL, 1492-NM16GL, 1492-NM36

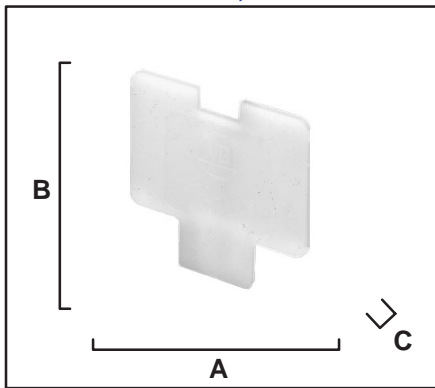

1492-N16, 1492-N17, 1492-N18, 1492-N36

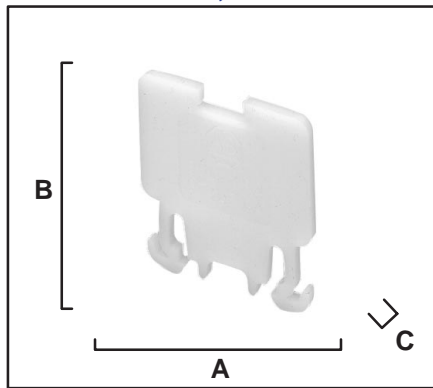

1492-N37

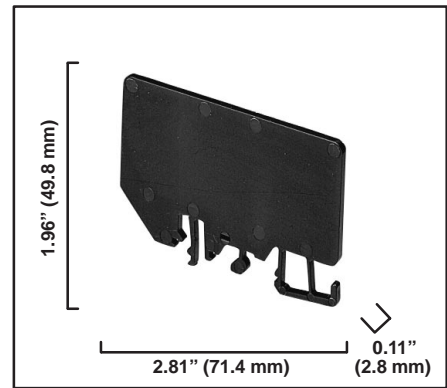

Catalog Number	A	B	C
1492-NM16	1.50" (38.1 mm)	1.39" (35.3 mm)	0.07" (1.78 mm)
1492-NM16BL	1.50" (38.1 mm)	1.39" (35.3 mm)	0.07" (1.78 mm)
1492-NM16GL	1.50" (38.1 mm)	1.39" (35.3 mm)	0.07" (1.78 mm)
1492-NM36	1.56" (39.6 mm)	1.45" (36.8 mm)	0.07" (1.78 mm)

Catalog Number	A	B	C
1492-N16	1.50" (38.1 mm)	1.78" (45.2 mm)	0.11" (2.8 mm)
1492-N17	1.75" (44.5 mm)	2" (50.8 mm)	0.14" (3.6 mm)
1492-N18	1.25" (31.8 mm)	1.13" (28.7 mm)	0.11" (2.8 mm)
1492-N36	1.56" (39.6 mm)	1.68" (42.5 mm)	0.11" (2.8 mm)

1492-N40

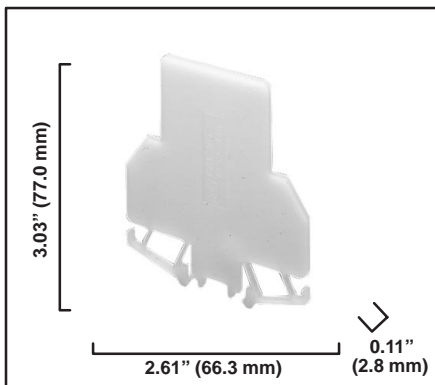

1492-NM40

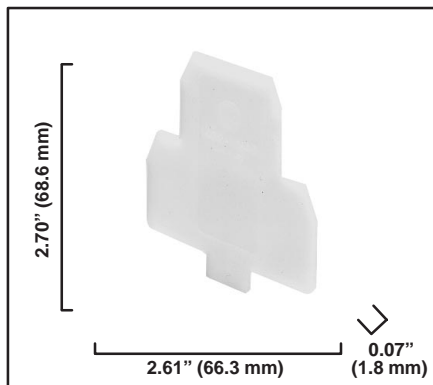

PARTITION PLATES

**1492-PP35, 1492-PPM3,
 1492-PP16**

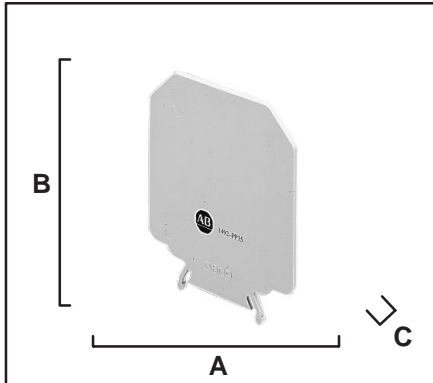

Catalog Number	A	B	C
1492-PP35	2.68" (68 mm)	2.99" (76 mm)	0.08" (2 mm)
1492-PPM3	1.57" (40 mm)	1.20" (30.5 mm)	0.08" (2 mm)
1492-PP16	2.36" (60 mm)	2.34" (59.5 mm)	0.08" (2 mm)

**1492-PPSL3, 1492-PP3,
 1492-PP10**

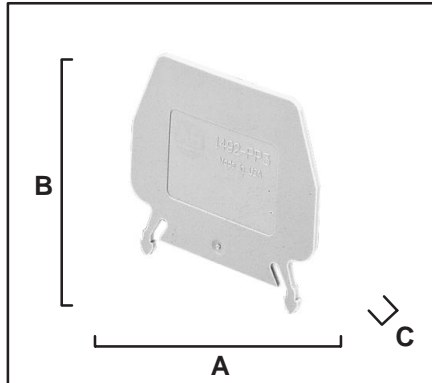

Catalog Number	A	B	C
1492-PP3	1.85" (47 mm)	1.57" (40 mm)	0.06" (1.5 mm)
1492-PP10	2.17" (55 mm)	1.81" (46 mm)	0.06" (1.5 mm)
1492-PPSL3	2.20" (56 mm)	1.54" (39 mm)	0.08" (2 mm)

1492-PPD3, 1492-PPD6

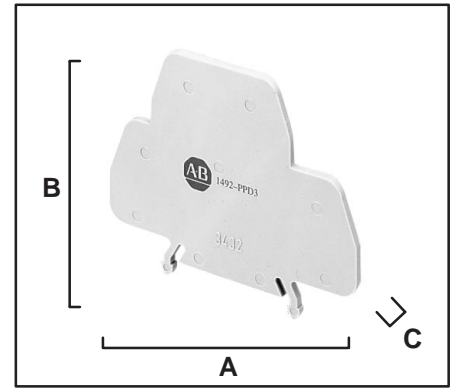

Catalog Number	A	B	C
1492-PPD3	2.82" (71.6 mm)	2.09" (53.2 mm)	0.08" (2.0 mm)
1492-PPD6	3.31" (84 mm)	2.72" (69 mm)	0.08" (2.0 mm)

1492-PPMD1

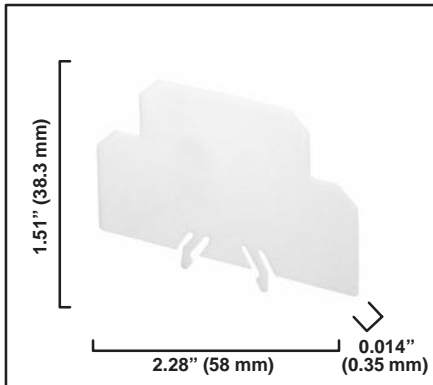

1492-PPD4P

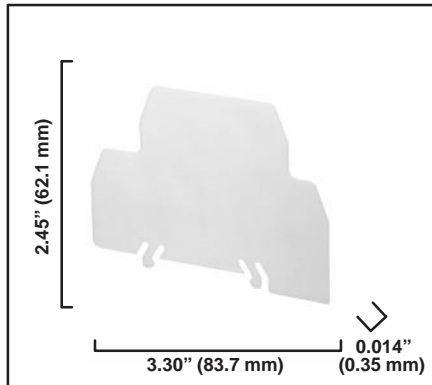

1492-PPTS3

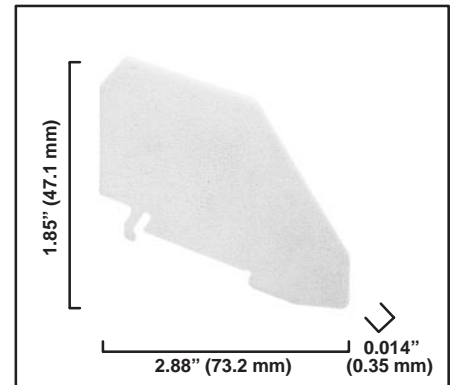

SEPARATION PLATES

1492-SP3

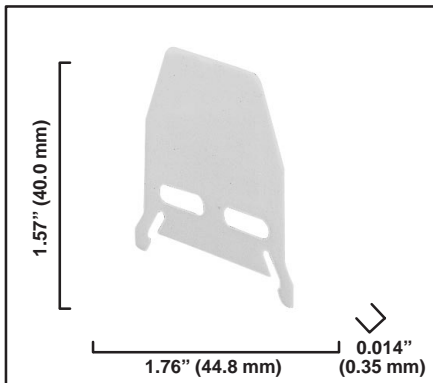

1492-SPD3

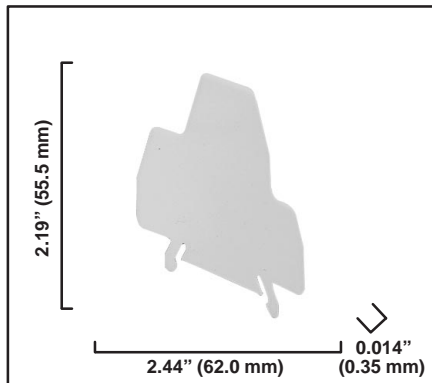

Note: Height dimension is measured from top of rail to top of partition or separation plate.

Accessories

Jumpers/Fanning Strips/Fuse Holder

SIDE JUMPERS/FANNING STRIP/INSTALLATION ACCESSORIES

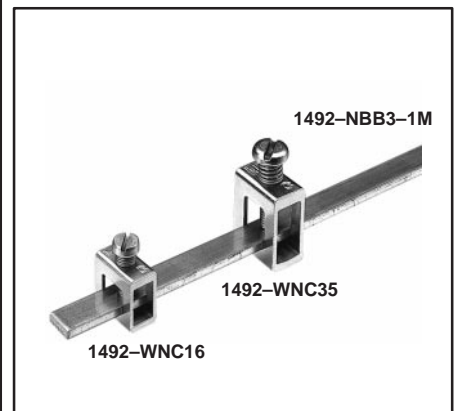
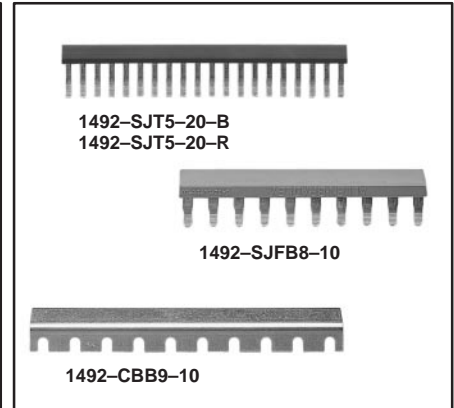
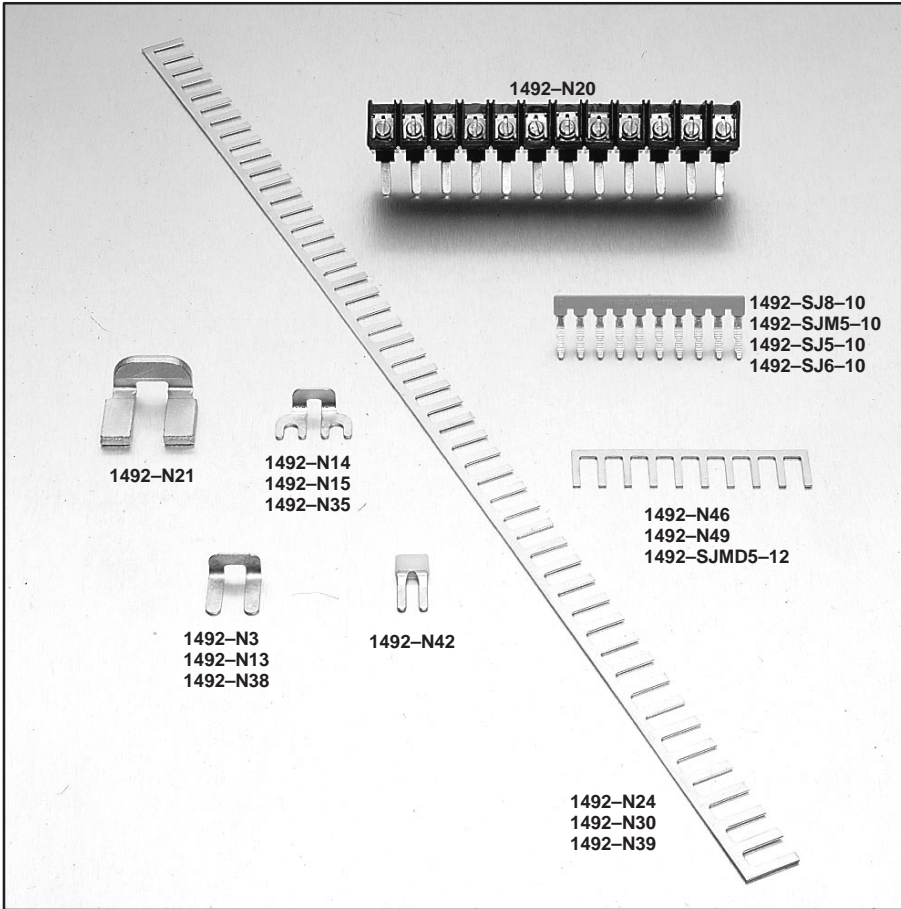

CENTER JUMPER BARS – IEC 1492-CJ...

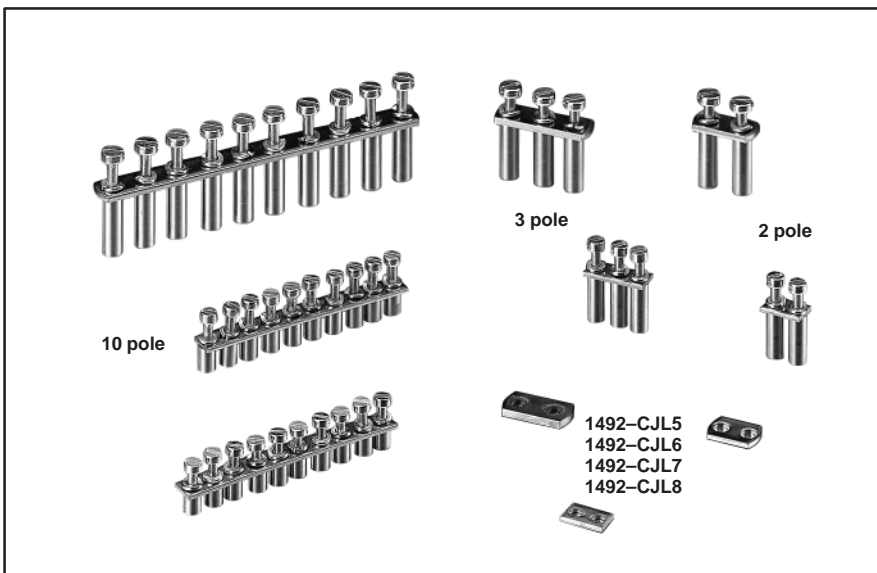

FUSE HOLDER 1492-IFMFH1



FUSE PULLER

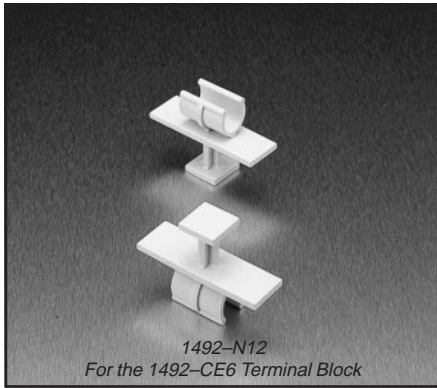

SCREWDRIVER AND MARKING PEN

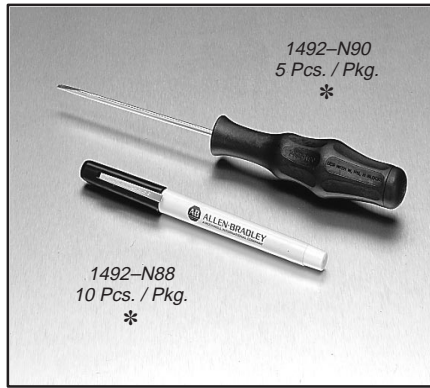

TEST PLUG/TEST SOCKETS
1492-TA285



1492-TA40, 1492-TA40L

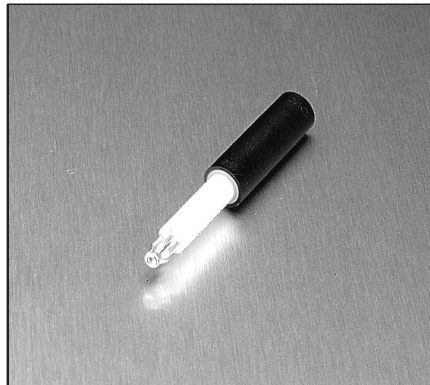

1492-TP15

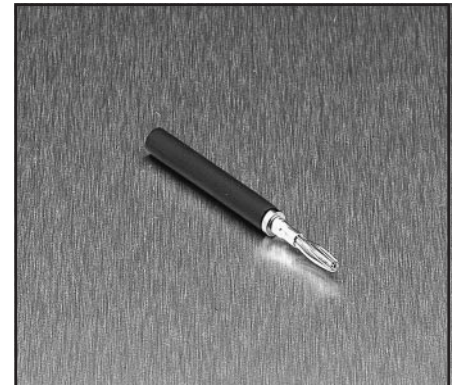

1492-TP23



1492-TP28



WARNING PLATES/COVERS/GROUP MARKER

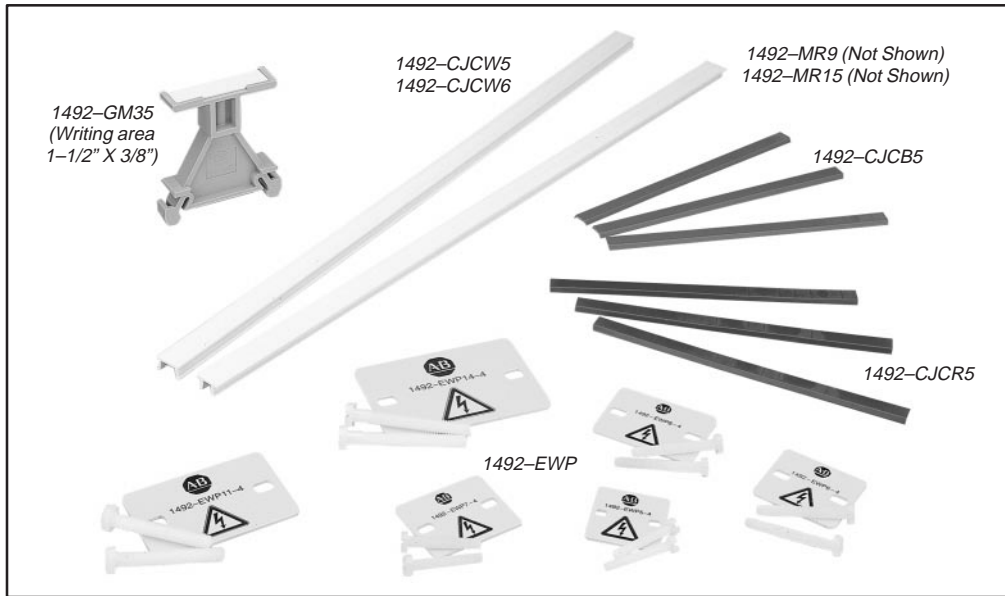

**QUICKCLAMP™ CENTER
 JUMPERS/LINKS**

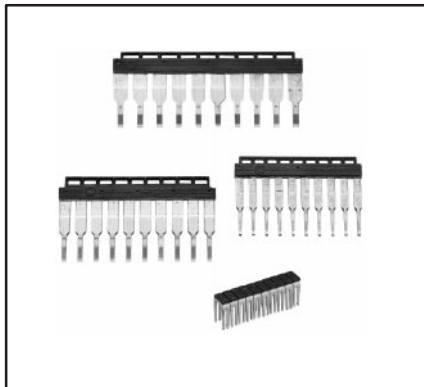

**QUICKCLAMP™
 INSULATION STOPS**



Catalog No.	Pcs./Pkg.	*
1492-CJR5-10	10	
1492-CJR5-10-B	10	
1492-CJR5-10-R	10	
1492-CJR6-10	10	
1492-CJR8-10	10	
1492-CJRL5	10	
1492-CJRL6	10	

Catalog No.	Pcs./Pkg.	*
1492-PS3-02	10	
1492-PS3-05	10	
1492-PS3-10	10	
1492-PS4-05	10	
1492-PS4-15	10	
1492-PS6-05	10	
1492-PS6-15	10	

END RETAINERS and TERMINAL COVERS

1492-ER35

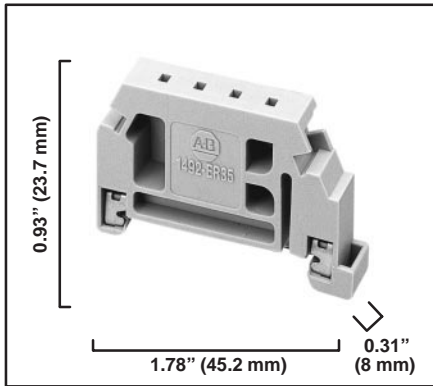

1492-TC4

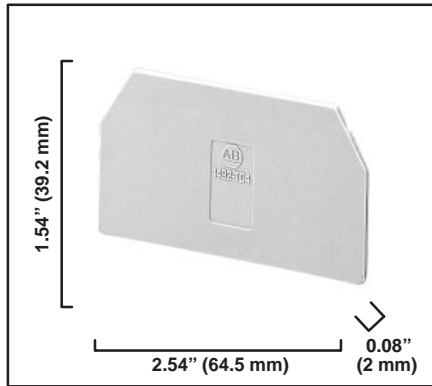

1492-TC3

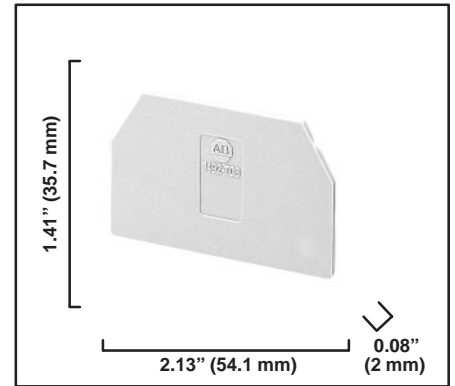

1492-TC3Q

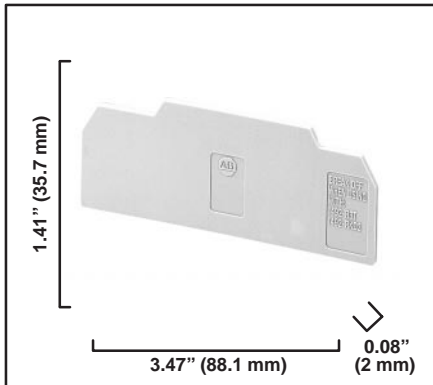

1492-TC4Q

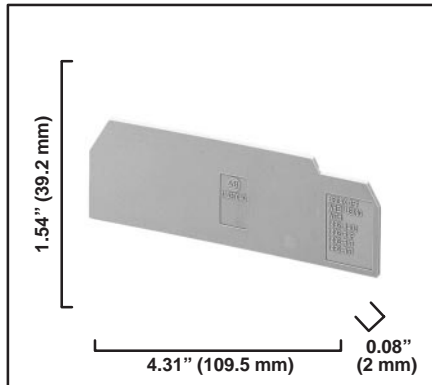

1492-TCS

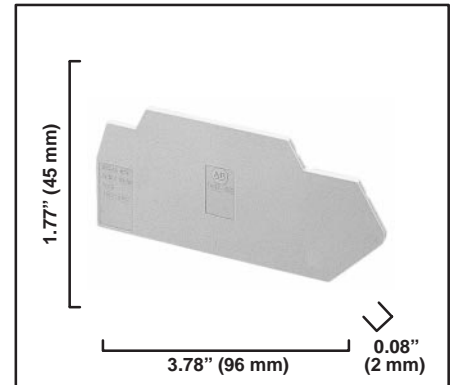

1492-TCD

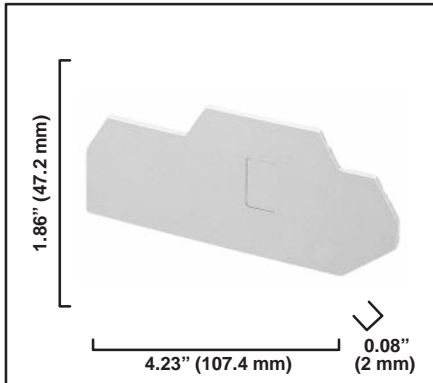

MARKING SYSTEMS

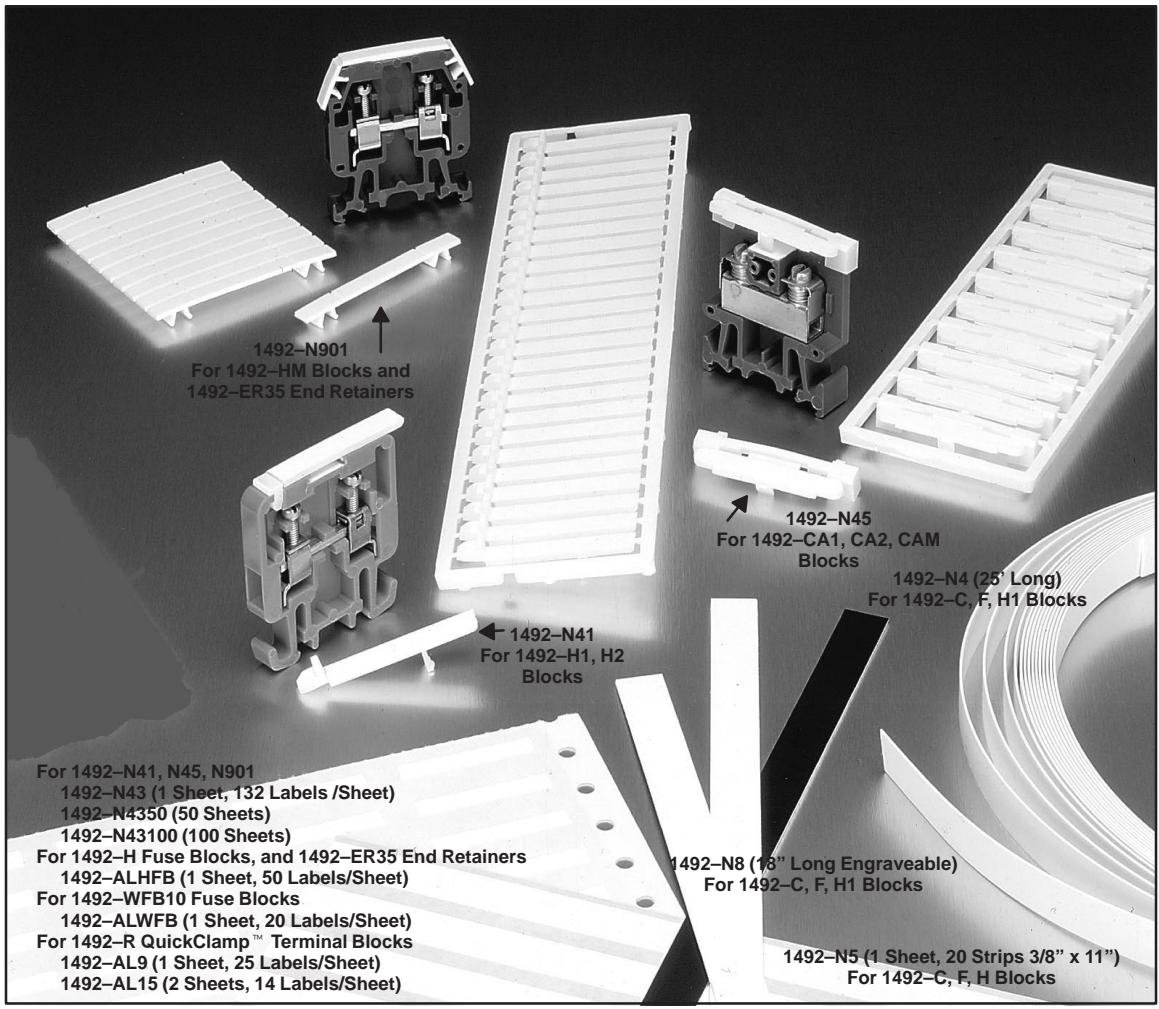

Note: The center and the corners of the 1492-R terminal blocks may be labeled using a 1492-MR9 marking rod, or 1492-AL9 label, or both. For maximum marking space, the 1492-MR15 can be used with or without the 1492-AL15 in the center of the block (this will cover the center jumper area).

Catalog No.	Pcs./Pkg.	*
1492-N4	1	
1492-N5	1	
1492-N8	25	
1492-N41	50	
1492-N43	1	
1492-N4350	1	
1492-N43100	1	
1492-N45	20	
1492-N901	50	
1492-ALHFB	1	
1492-ALWFB	1	
1492-MR9 (Not Shown)	25	
1492-MR15 (Not Shown)	25	

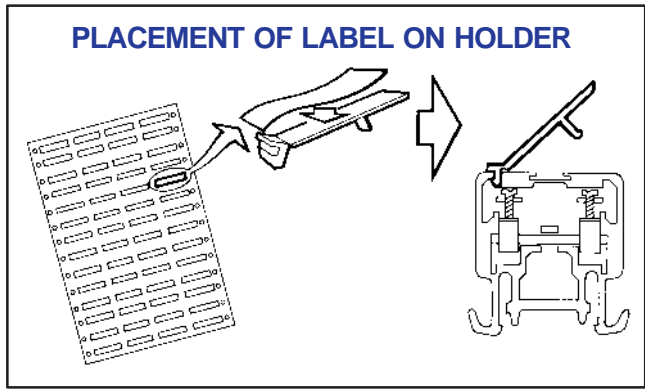

MARKER CARDS

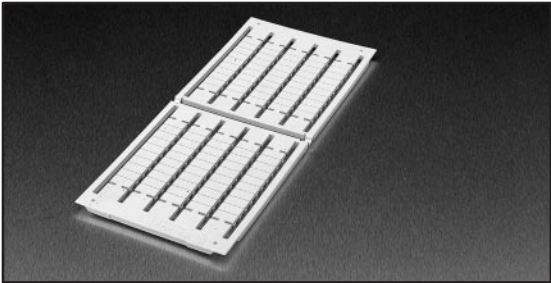

Catalog No.	Number of Labels/Card	*
1492-SM5X5	100	
1492-SM5X9	100	
1492-SM5X12	100	
1492-SM6X9	100	
1492-SM6X12	100	
1492-SM8X9	100	
1492-SM8X12	100	
1492-SMN81	100	
1492-SMN83	50	

IEC MARKING SYSTEMS



MARKING SYSTEM HARDWARE

Description	Catalog No.	Pcs./ Pkg.	*
Plotter Starter Kit: Plotter & Cable Software Base Plate (6) IEC Spacers (6) SMN Spacers (6) SM5X5 Spacers	1492-PLTKIT	1	
Disposable Plotter Pen	1492-DISPEN	4	

**STANDARD PRE-PRINTED MARKER CARDS, 10 Numbers in Series
 (Minimum Order of 1 Card)**

HORIZONTAL
 (Shown approx. 50% of actual size.)

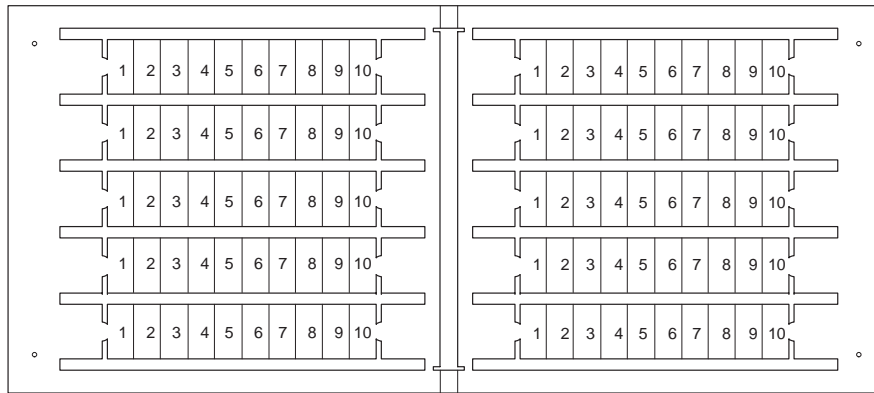

CATALOG NUMBER EXPLANATION

1492 – SM 6X9 H 1–10

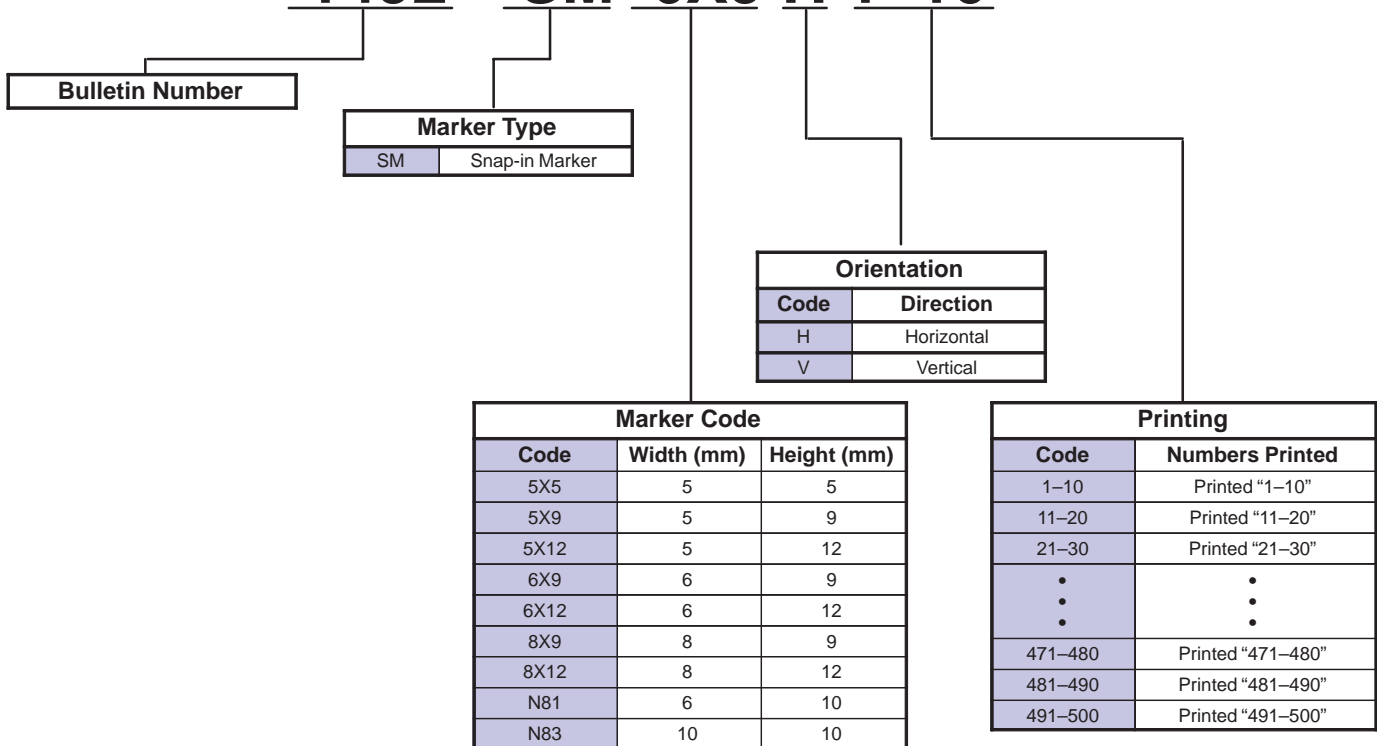

STANDARD PRE-PRINTED MARKER CARDS, 50 Numbers in Series
 (Minimum Order of 1 Card)

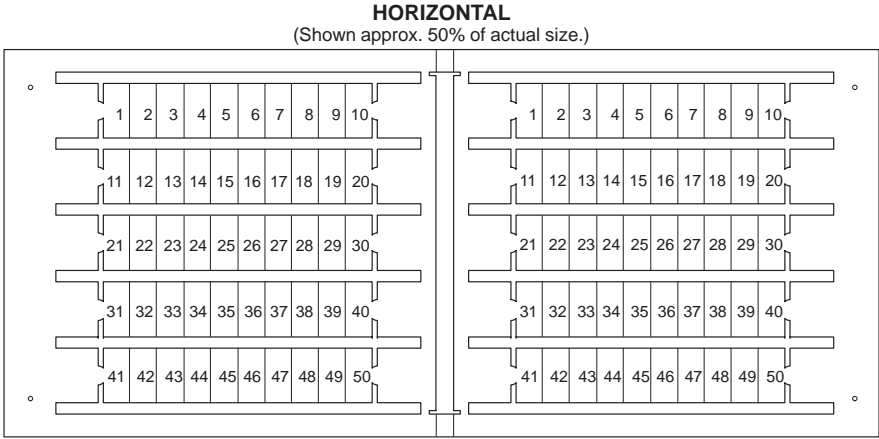

CATALOG NUMBER EXPLANATION

1492 – SM 6X9 H 1–50

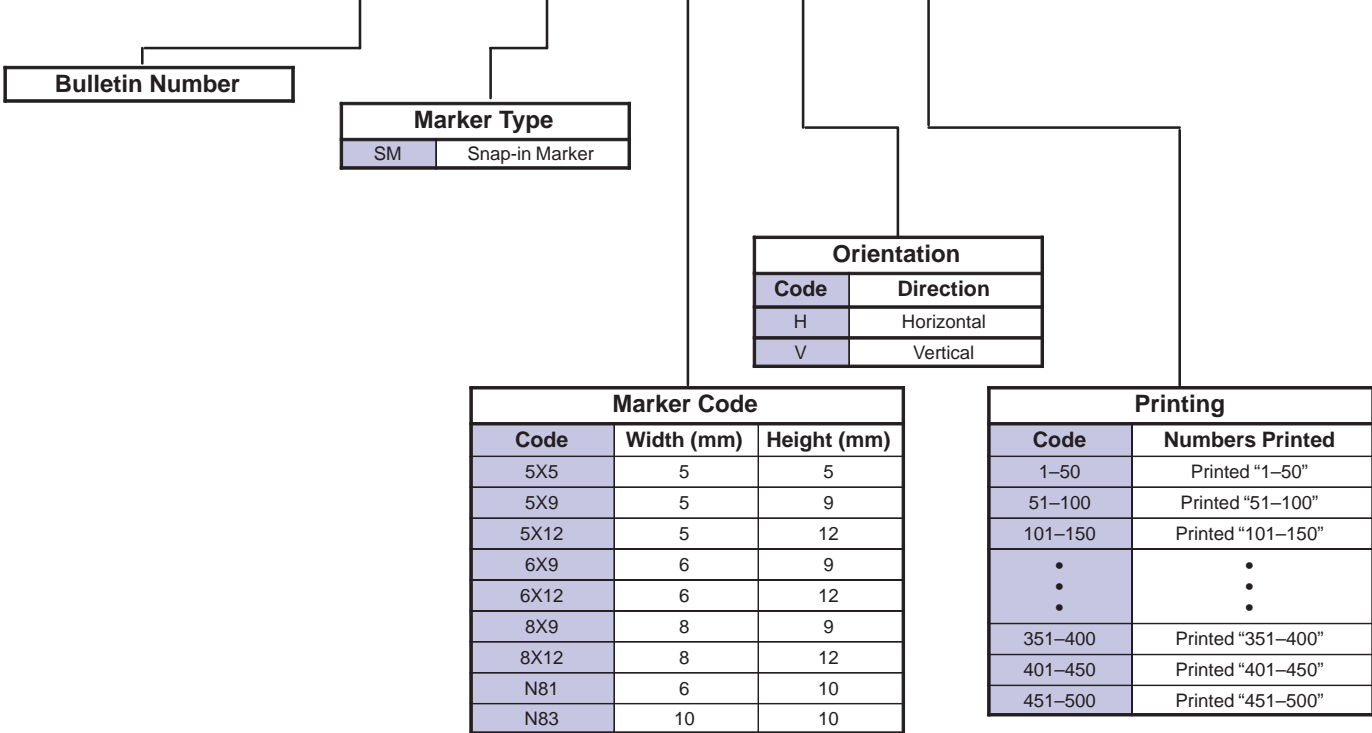

**STANDARD PRE-PRINTED MARKER CARDS, 100 Numbers in Series
 (Minimum Order of 1 Card)**

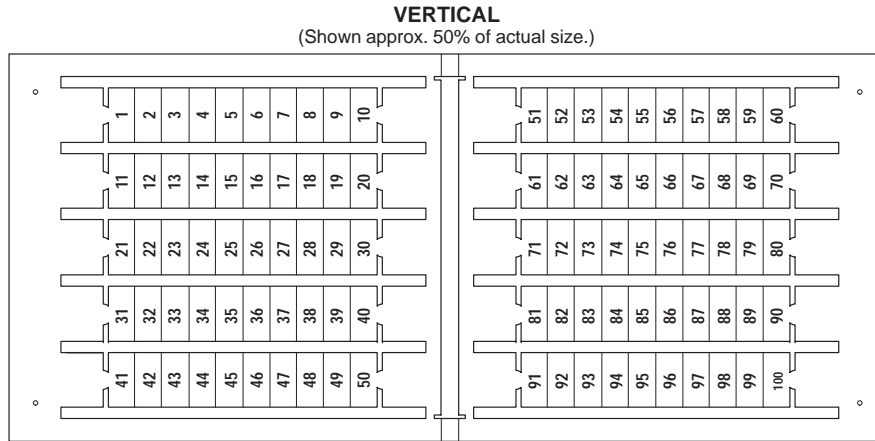

CATALOG NUMBER EXPLANATION

1492 – SM 6X9 V 1-100

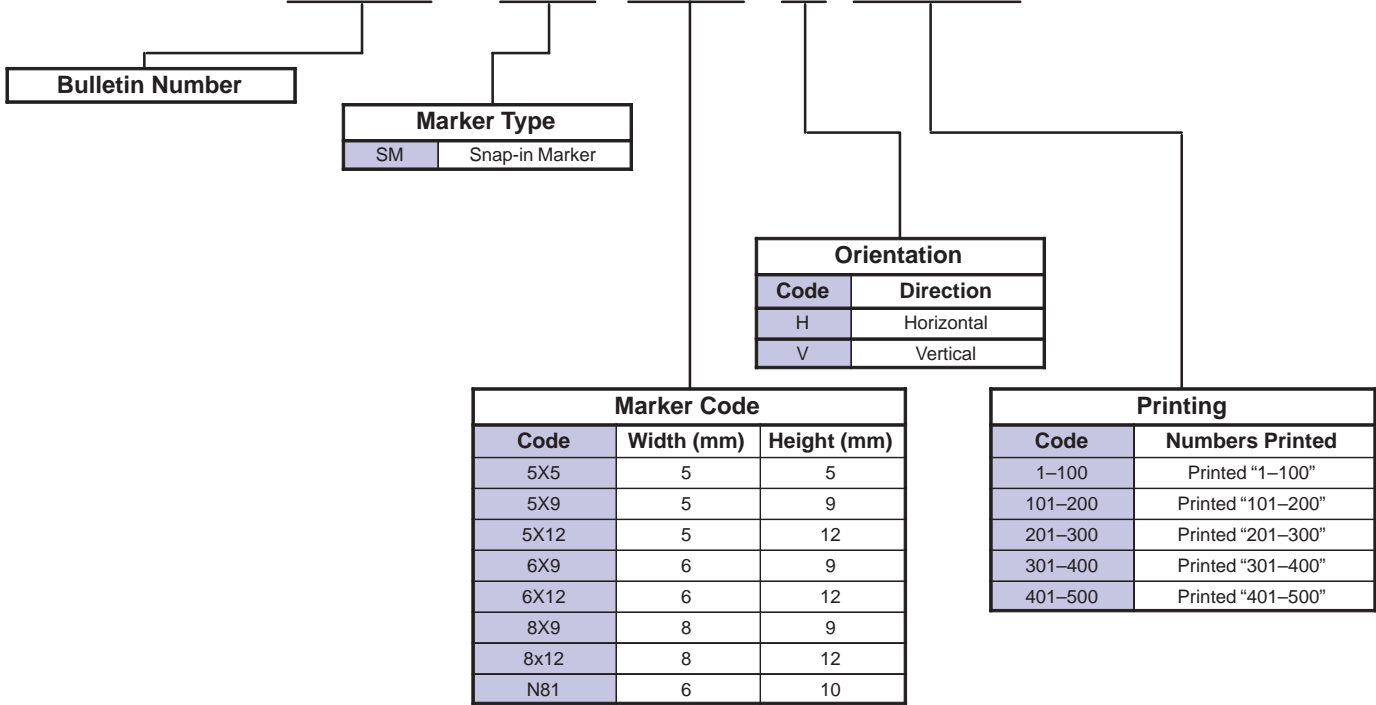

SINGLE DIGIT PRE-PRINTED MARKER TABS

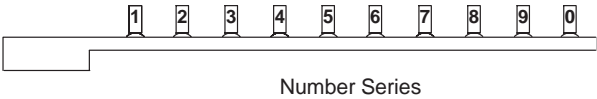
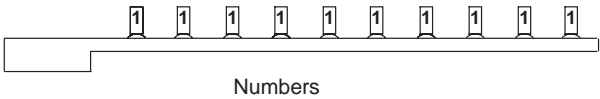

Numbers		
Printing	Catalog Number	Pcs/Pkg
0	1492-MP-0	10
1	1492-MP-1	10
2	1492-MP-2	10
3	1492-MP-3	10
4	1492-MP-4	10
5	1492-MP-5	10
6	1492-MP-6	10
7	1492-MP-7	10
8	1492-MP-8	10
9	1492-MP-9	10

Number Series		
Printing	Catalog Number	Pcs/Pkg
0-9	1492-MP	10

Letters		
Printing	Catalog Number	Pcs/Pkg
A	1492-MP-A	10
B	1492-MP-B	10
C	1492-MP-C	10
D	1492-MP-D	10
E	1492-MP-E	10
F	1492-MP-F	10
G	1492-MP-G	10
H	1492-MP-H	10
I	1492-MP-I	10
J	1492-MP-J	10
K	1492-MP-K	10
L	1492-MP-L	10
M	1492-MP-M	10
N	1492-MP-N	10
P	1492-MP-P	10
Q	1492-MP-Q	10
R	1492-MP-R	10
S	1492-MP-S	10
T	1492-MP-T	10
U	1492-MP-U	10
V	1492-MP-V	10
W	1492-MP-W	10
X	1492-MP-X	10
Y	1492-MP-Y	10
Z	1492-MP-Z	10

Special Symbols		
Printing	Catalog Number	Pcs/Pkg
+	1492-MP-POS	10
\perp	1492-MP-GND	10
-	1492-MP-NEG	10
~	1492-MP-AC	10
=	1492-MP-DC	10

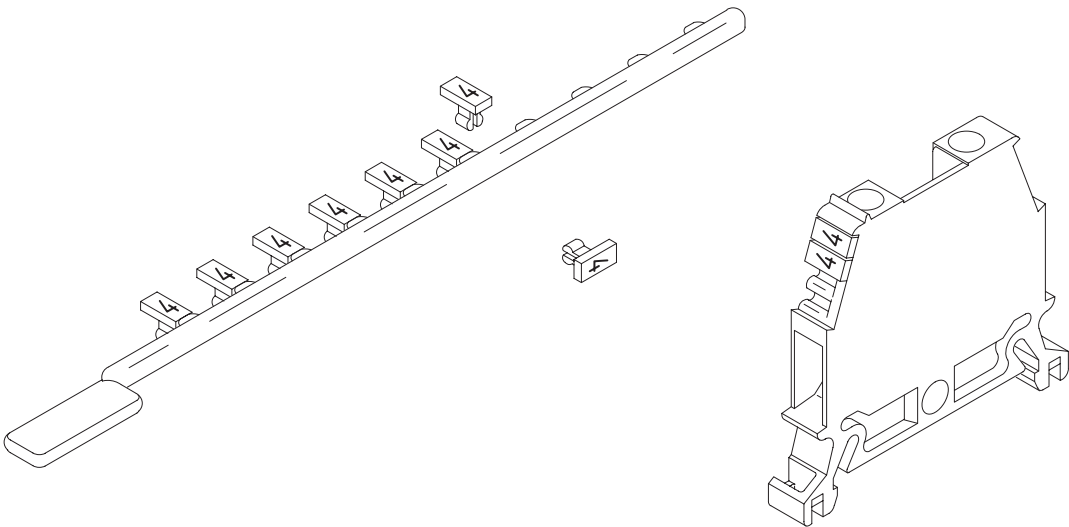

CUSTOM PRINTED MARKER CARDS

HORIZONTAL
 (Shown approx. 50% of actual size.)

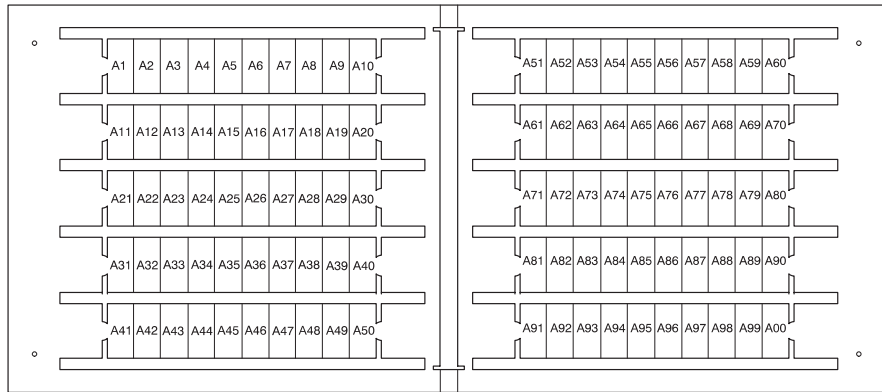

PROCEDURE FOR ORDERING CUSTOM 1492 MARKER CARDS

Step 1

Locate the correct form on the following pages. Fill out the customer information at the top. **(Contact name and phone number are very important.)**

Step 2

Check the marker type desired.

Step 3

Fill in the order form, observing the following:

- Each marker card consists of 50 or 100 labels

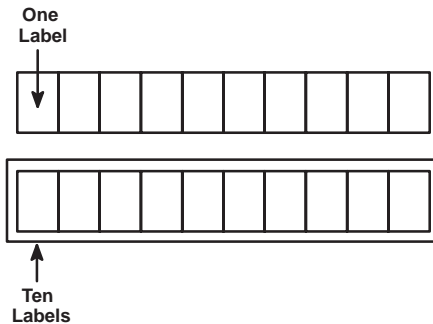

- A minimum of one marker **CARD** of a specified type is required to place an order.
- Marked cards are available only in black ink.

- Print as clearly as possible or type.
- Box in all numbers on the order form to distinguish them from alpha characters. Unboxed numbers will be read as alpha characters.

I 103	OIL	O 23	1010						
-------	-----	------	------	--	--	--	--	--	--

- Sequential numbering is acceptable using an arrow between the first and last label.

2									11
724									733

- Distinguish the lower case letter "l" from the capital letter "I" by scripting the letter "l" and including both the top and bottom lines on the letter "I".

Label	Input	l							
-------	-------	---	--	--	--	--	--	--	--

- Blank spaces are acceptable and should be shown with a caret (^). (Example: PLC^DER)
- Blank labels are also acceptable and should be left entirely blank with no text or markings of any kind. **DO NOT** write the word "BLANK," as it will be printed.

Step 4

Review order form for clarity and accuracy. Make sure all the requested information is provided.

Step 5

Make a copy of all completed forms for your records.

Step 6

Send original forms to your local Allen-Bradley distributor for order entry.

EXAMPLES AND SPECIFICATIONS FOR CUSTOM MARKING CARDS

Terminal Block Marker Coordination Table

The table below coordinates the marker card with a given terminal block or terminal block prefix.

1492-SM5X5C	1492-SM5X9C		1492-SM6X9C		1492-SM6X12C		1492-SM8X12C
1492-WM3 1492-WMD1 1492-CP4	1492-W3 1492-WR3 1492-WD3 1492-W3TW 1492-WKD3 1492-WKD3TP 1492-WTC3E 1492-WTC3J 1492-WTC3K 1492-R3 1492-R3T 1492-R3Q 1492-RKD3 1492-RTS2	1492-WTC3T 1492-WTF3 1492-WTF3LP 1492-WTF3LN 1492-WTS3 1492-WTS3LP 1492-WTS3LN 1492-RTSG2 1492-RG3	1492-WM4 1492-WD4 1492-WD4C 1492-WD4PTP 1492-WD4DF 1492-WD4DR 1492-WD4RA 1492-WDG4ND 1492-WDG4NSS 1492-FP4 1492-FP424 1492-FP4250 1492-WD4P 1492-R4 1492-R4T 1492-R4Q 1492-R4P 1492-R4DU 1492-RG4	1492-WDG4P 1492-WD4N 1492-WDG4N 1492-WDG4 1492-WFB4① 1492-WFB424① 1492-WFB4250① 1492-WDG4PTP 1492-WD4RC001 1492-WD4SS 1492-WD4PSS 1492-WD4PSSTP 1492-WDG4PSS 1492-WDG4PSSTP	1492-EA35 1492-W4 1492-W6 1492-W16 1492-W16S 1492-W35 1492-W70 1492-W16S 1492-W4PTP 1492-WD6 1492-R4② 1492-R4DJ 1492-R4Q②	1492-WG4 1492-WG6 1492-WG10 1492-WG16 1492-WG35 1492-WLD10 1492-W4P 1492-WKD6 1492-WLD10C 1492-R4P③ 1492-RG4	1492-WFB4② 1492-WFB424② 1492-WFB4250② 1492-W10 1492-WG10S 1492-R6③ 1492-R6T③ 1492-RG6 1492-ER35 1492-H4 1492-H5 1492-H6 1492-H7
1492-SMN81C	1492-SMN83C	1492-SM5X12	1492-SM8X9				
1492-HM1 1492-HM2 1492-HM2... 1492-HM3 1492-WFB10...④	1492-WFB10...① 1492-CB... 1492-GH... 1492-GS...	1492-R3 1492-R3T 1492-R3Q 1492-RKD3 1492-RTS2 1492-RTSG2 1492-RG3	1492-R6 1492-R6T 1492-RG6 1492-ER35 1492-H4 1492-H5 1492-H6 1492-H7				

- ① Handle Marker Size.
- ② Base Marker Size.
- ③ Marker will block center jumper access.

Maximum Marking Parameters

The following table shows the maximum number of characters allowed per label. Maximums are represented by the first label of each strip in the examples below.

Marker Type	Marker Orientation			
	Horizontal		Vertical	
	Rows	Characters	Rows	Characters
1492-SM5X5	1	5	1	4
1492-SM5X9	2	5	1	10
1492-SM5X12	3	5	1	12
1492-SM6X9	2	6	2	10
1492-SM6X12	3	6	2	12
1492-SM8X9	2	8	3	10
1492-SM8X12	3	8	3	12
1492-SMN81	2	6	2	10
1492-SMN83	2	10	3	10

Marking Examples

VERTICALLY ORIENTED MARKER

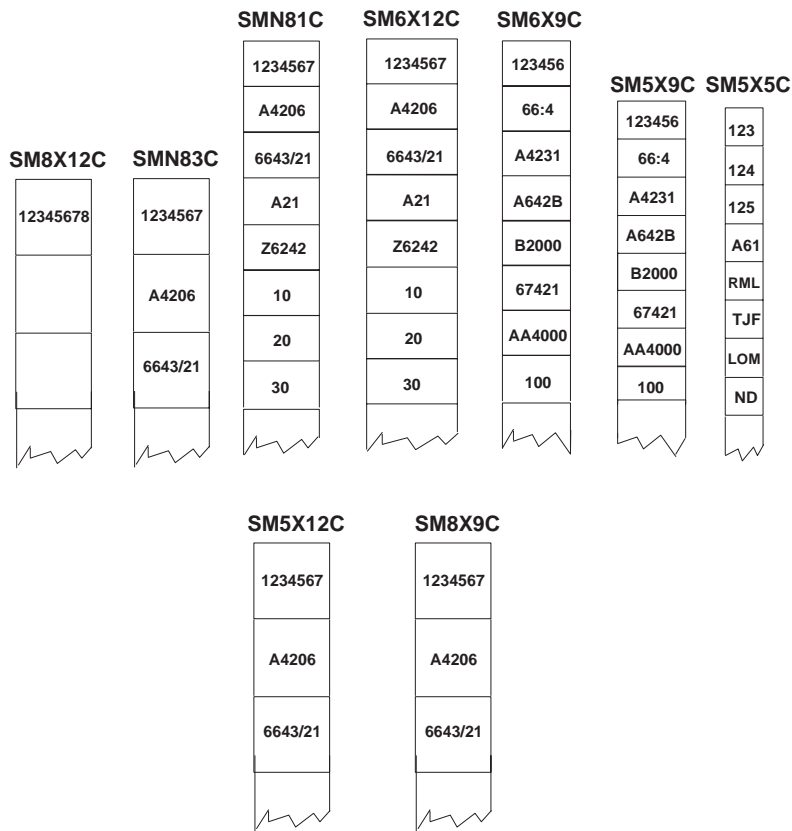

HORIZONTALLY ORIENTED MARKER

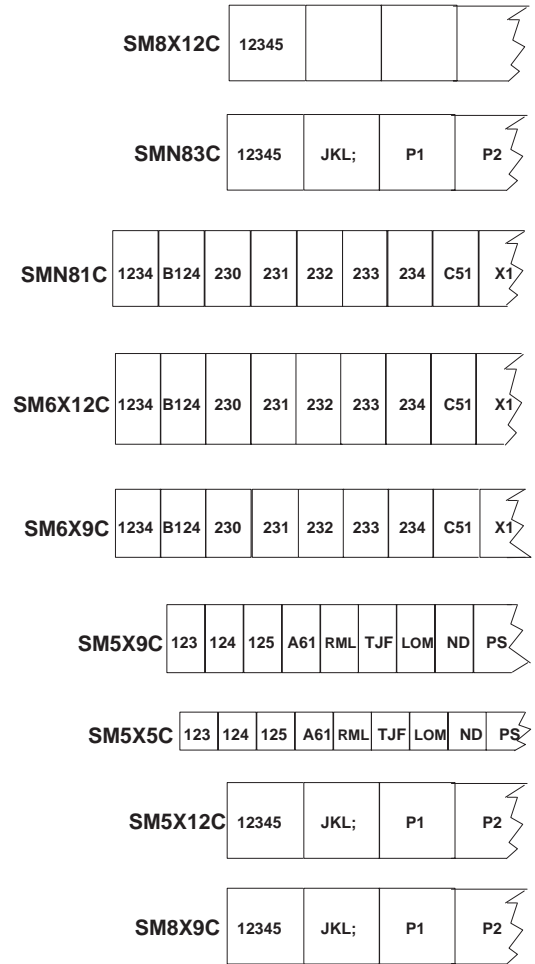

Available Marking Symbols

The following symbols can be marked on an individual label. Draw the symbol desired (in the correct orientation) on the marker card order form.

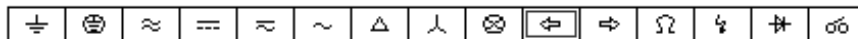

CUSTOM PRINTED MARKER — ORDER FORM

Note: For the maximum number of rows and characters that may be used, please refer to Maximum Marking Parameters on page 12-161.

Customer: _____ Date: _____

Customer Contact Name: _____ Phone Number: _____

Distributor: _____ (For Distributor Use Only)

Note: Consult local sales office for special marking requests.

A-B Sales Order # _____	Item _____
Distributor Contact Name _____	

Marker Card <small>(Select only one type per page by placing an "X" in the desired box.)</small>	Quantity	Used on the Following Terminal Blocks and Accessories
1492-SM5X5C <input type="checkbox"/>		1492-WM3, WMD1, CP4,
1492-SM5X9C <input type="checkbox"/>		1492-W3, WR3, WD3, W3TW, WKD3, WKD3TP, WTC3E, WTC3J, WTC3K, WTC3T, WTF3, WTF3LP, WTF3LN, WTS3, WTS3LP, WTS3LN, R3, R3T, R3Q, RKD3, RD3, RTS2, RTSG2, RG3
1492-SM5X12C <input type="checkbox"/>		1492-R3, R3T, R3Q, RKD3, RD3, RG3
1492-SM6X9C <input type="checkbox"/>		1492-WM4, WD4, WD4C, FP4, FP424, FP4250, WD4P, WDG4P, WD4N, WDG4N, WDG4, WFB4, WFB424, WFB4250, R4, R4T, R4Q, R4P, R4DJ, RG4, WMG4
1492-SM6X12C <input type="checkbox"/>		1492-EA35, W4, W6, W16, W35, W70, WSL3, W4PTP, WD6, WG4, WG6, WG10, WG16, WG35, WLD10, W4P, WKD6, W16S, WLD10C, R4, R4T, R4Q, R4P, R4DJ, RG4
1492-SM8X9C <input type="checkbox"/>		1492-R6, R6T, ER35, RG6, H4, H5, H6, H7
1492-SM8X12C <input type="checkbox"/>		1492-WFB4, WFB424, WFB4250, W10, WG10S, R6, R6T, ER35, RG6, H4, H5, H6, H7
1492-SMN81C <input type="checkbox"/>		1492-WFB10..., HM1, HM2, HM3

Vertical Example

Please orient text as desired on the card.

Horizontal Example

A	B	C	D	E	F	G	V <input type="checkbox"/> 24 +	GND	I <input type="checkbox"/> 027 x

V <input type="checkbox"/> 24 +	GND	I <input type="checkbox"/> 027 x	H	I	J	K	L	M	N

CUSTOM PRINTED MARKER — ORDER FORM

Note: For the maximum number of rows and characters that may be used, please refer to Maximum Marking Parameters on page 12-161.

Customer: _____

Date: _____

Customer Contact Name: _____

Phone Number: _____

Distributor: _____

(For Distributor Use Only)

Note: Consult local sales office for special marking requests.

A-B Sales Order # _____ Item _____
Distributor Contact Name _____

Marker Card (Select only one type per page by placing an "X" in the desired box.)	Quantity	Used on the Following Terminal Blocks
1492-SMN83C <input type="checkbox"/>		For use with: 1492-CB, GH, GS, WFB10HD, WFB10, WFB1024, WFB10250

Please orient text as desired on the card.

Vertical Example

Horizontal Example

A	B	V 24 +	GND	I 027 x
---	---	--	-----	---

V 24 +	GND	I 027 x	C	D
--	-----	---	---	---

--	--	--	--	--

--	--	--	--	--

--	--	--	--	--

--	--	--	--	--

--	--	--	--	--

--	--	--	--	--

--	--	--	--	--

--	--	--	--	--

--	--	--	--	--

--	--	--	--	--

MULTIPLE WIRE CONNECTION COMBINATIONS FOR STRANDED COPPER CONDUCTORS OF THE SAME CROSS SECTION FOR ALLEN-BRADLEY TERMINAL BLOCKS

IEC RATED TERMINAL BLOCKS															
Catalog Number	Wire Size AWG (mm ²)														
	#22	#20 (0.5)	#18 (0.75)	#16 (1.5)	#14 (2.5)	#12 (4)	#10 (6)	#8 (10)	#6 (16)	#4 (25)	#2 (35)	#1 (40)	1/0 (50)	2/0 (70)	3/0 (80)
	Number of the Same Size Wires Per Terminal Block														
1492-H4, -H5, -H6, -H7	4	4	3	2	2	1	—	—	—	—	—	—	—	—	—
1492-IFM..., -AIFM...	3	3	3	2	1	1	—	—	—	—	—	—	—	—	—
1492-W4	4	4	3	2	2	1	1	—	—	—	—	—	—	—	—
1492-W4P	—	3	2	2	2	1	—	—	—	—	—	—	—	—	—
1492-W4PTP	—	3	2	2	2	1	—	—	—	—	—	—	—	—	—
1492-W6	4	4	3	2	2	1	1	—	—	—	—	—	—	—	—
1492-W10	4	4	4	4	3	2	1	1	—	—	—	—	—	—	—
1492-W16 ^①	—	—	—	—	2	2	2	1	1	1	—	—	—	—	—
1492-W16S	—	—	—	—	4	3	2	2	1	1	—	—	—	—	—
1492-W35 ^①	—	—	—	—	3	2	2	2	1	1	1	1	1	—	—
1492-W70 ^①	—	—	—	—	—	—	—	—	—	1	1	1	1	1	1
1492-WD6 ^①	—	—	3	2	2	1	1	—	—	—	—	—	—	—	—
1492-WD4DF	4	4	3	2	2	1	—	—	—	—	—	—	—	—	—
1492-WD4DR	4	4	3	2	2	1	—	—	—	—	—	—	—	—	—
1492-WD4P	4	4	3	2	2	1	—	—	—	—	—	—	—	—	—
1492-WD4PSS	—	—	3	2	2	1	—	—	—	—	—	—	—	—	—
1492-WD4PSSSTP	—	—	3	2	2	1	—	—	—	—	—	—	—	—	—
1492-WD4PTP	4	4	3	2	2	1	—	—	—	—	—	—	—	—	—
1492-WD4RA	4	4	3	2	2	1	—	—	—	—	—	—	—	—	—
1492-WD4RC001	4	4	3	2	2	1	—	—	—	—	—	—	—	—	—
1492-WD4SS	—	—	3	2	2	1	—	—	—	—	—	—	—	—	—
1492-WD4N ^{①②}	4	4	3	2	2	1	—	—	—	—	—	—	—	—	—
1492-WDG4N ^{①②}	4	4	3	2	2	1	—	—	—	—	—	—	—	—	—
1492-WDG4ND ^{①②}	4	4	3	2	2	1	—	—	—	—	—	—	—	—	—
1492-WDG4NSS ^{①②}	—	—	3	2	2	1	—	—	—	—	—	—	—	—	—
1492-WDG4P...	4	4	3	2	2	1	—	—	—	—	—	—	—	—	—
1492-WDG4PTP	4	4	3	2	2	1	—	—	—	—	—	—	—	—	—
1492-WDG4PSS	—	—	3	2	2	1	—	—	—	—	—	—	—	—	—
1492-WDG4PSSSTP	—	—	3	2	2	1	—	—	—	—	—	—	—	—	—
1492-WFB4	4	4	3	2	2	1	—	—	—	—	—	—	—	—	—
1492-WFB10 ^①	—	—	4	3	2	2	1	1	—	—	—	—	—	—	—
1492-WG4	4	4	3	2	1	1	—	—	—	—	—	—	—	—	—
1492-WG6	4	4	3	2	2	1	1	1	—	—	—	—	—	—	—
1492-WG10 ^①	—	—	—	2	2	2	1	1	1	—	—	—	—	—	—
1492-WG10S ^①	4	4	4	4	3	2	1	1	—	—	—	—	—	—	—
1492-WG16 ^①	—	—	—	—	—	—	2	1	1	1	—	—	—	—	—
1492-WG35 ^①	—	—	—	—	—	—	—	—	2	1	1	1	1	—	—
1492-WKD3TP	4	4	3	2	1	—	—	—	—	—	—	—	—	—	—
1492-WKD6 ^①	—	—	3	2	2	1	1	—	—	—	—	—	—	—	—
1492-WLD10 ^① , -WLD10C ^①	—	—	3	2	2	1	1	1	—	—	—	—	—	—	—
1492-WMD1	2	1	1	1	—	—	—	—	—	—	—	—	—	—	—
1492-WMG3 ^①	—	—	—	—	1	—	—	—	—	—	—	—	—	—	—
1492-WM3, -W3TW	4	3	2	1	1	—	—	—	—	—	—	—	—	—	—
1492-WTF3, -WTS3 ^③	4	4	3	2	1	—	—	—	—	—	—	—	—	—	—
1492-UF3	4	4	3	2	2	1	—	—	—	—	—	—	—	—	—
1492-W3, -WD3, -WKD3, -WR3	4	4	3	2	1	—	—	—	—	—	—	—	—	—	—
1492-WM4, -WD4, -WD4C, -WMG4 ^①	4	4	3	2	2	1	—	—	—	—	—	—	—	—	—

① The Multiple wire combinations for these products had not been tested at time of publication. Consult factory for latest wire combination information.
 ② These products have been approved for use with #24 AWG wire.
 ③ 1492-WTF.. and 1492-WTS.. blocks have also been tested for 4 #26 AWG and 4 #24 AWG wires.

MULTIPLE WIRE CONNECTION COMBINATIONS FOR STRANDED COPPER CONDUCTORS OF THE SAME CROSS SECTION FOR ALLEN-BRADLEY TERMINAL BLOCKS...CONTINUED

NEMA RATED TERMINAL BLOCKS												
Catalog Number	Wire Size AWG											
	#22	#20	#18	#16	#14	#12	#10	#8	#6	#4	#2	#1/0
	Number of the Same Size Wires Per Terminal Block											
1492-F1⓪, -F2⓪, -F8⓪	3	3	3	2	1	—	—	—	—	—	—	—
1492-CA1⓪	4	4	4	3	2	2	1	1	—	—	—	—
1492-CA1L⓪	4	4	4	3	2	2	1	1	—	—	—	—
1492-CAM1⓪	4	4	4	3	2	2	1	1	—	—	—	—
1492-CAM1L⓪	4	4	4	3	2	2	1	1	—	—	—	—
1492-CA2⓪	4	4	4	3	2	2	1	1	—	—	—	—
1492-CAM2⓪	4	4	4	3	2	2	1	1	—	—	—	—
1492-CD2⓪	—	—	—	—	4	3	2	2	1	1	—	—
1492-CE2⓪	—	—	—	—	—	4	4	4	3	2	1	1
1492-CD8⓪	4	4	4	3	2	2	1	—	—	—	—	—
1492-CE6⓪	4	4	4	3	2	2	1	—	—	—	—	—
1492-CE9⓪	4	4	4	3	2	2	1	—	—	—	—	—
1492-H1, -HM1⓪	4	4	3	2	2	1	—	—	—	—	—	—
1492-H2, -HM2⓪⓪	4	4	3	2	2	1	—	—	—	—	—	—
1492-H4, -H5, -H6, -H7	4	4	3	2	2	1	—	—	—	—	—	—
1492-HC6	4	4	3	2	2	1	—	—	—	—	—	—
1492-HM3⓪	4	4	4	3	2	2	1	1	—	—	—	—
1492-UF3	4	4	3	2	2	1	—	—	—	—	—	—

⓪ Also colors.

⓪ Also Catalog Numbers 1492-H2D, -H2R, -H2K, -H2C, -H2V, -HM2D, -HM2R, -HM2K, -HM2C, -HM2V.

Note: All 1492-R Style Terminal Blocks terminate one wire per termination, regardless of wire size.

NEMA & IEC TERMINAL BLOCK COMPONENT SPECIFICATIONS^①

Tie Point Terminal Blocks — Type H2C, HM2C and WD4C



ATTENTION: The total current flow through these terminal blocks (the sum of all inputs or the sum of all outputs) must not exceed the rated current for the device.

Description	Type	Rating
Maximum Total Current Flow Through the Terminal Block	H2C, HM2C	10A
	WD4C	20A
Maximum Working Voltage	H2C, HM2C	600V
	WD4C	300V
Operating Ambient Temperature Range	All	-20° to +40°C
Storage Temperature Range	All	-40° to +75°C

Diode Terminal Blocks — Types H2D, HM2D, WD4DF, WD4DR, RD3DF and RD3DR

Description	Symbol	Type	Rating
Peak Repetitive Reverse Voltage	V (RRM)	H2D, HM2D	600V
Working Peak Reverse Voltage	V (RWM)	RD3DF, RD3DR, WD4DF, WD4DR	300V
DC Blocking Voltage	V (R)		
Non-Repetitive Peak Reverse Voltage (Halfwave, single phase, 60 Hz)	V (RSM)	H2D, HM2D	600V
		RD3DF, RD3DR, WD4DF, WD4DR	300V
RMS Reverse Voltage ^②	V (Rrms)	H2D, HM2D	600V
		RD3DF, RD3DR, WD4DF, WD4DR	300V
Average Rectified Forward Current Single Phase, Resistive Load, 60 Hz	I (O)	All	1.0A
Non-Repetitive Peak Surge Current (Surge applied at rated load)	I (FSM)	All	30A (1 cycle)
Maximum Forward Voltage Drop [I (F) = 1.0A]	V (F)	All	1.1 Volt
Maximum Reverse Current	I (R)	All	10 μA
Operating Ambient Temperature Range	T (A)	All	-20° to +40°C
Storage Temperature Range	T (S)	All	-40° to +75°C

All parameters measured at 25°C.

Resistor Terminal Blocks — Types H2RA, H2RB, H2RC, HM2RA, HM2RB, HM2RC, RD3RB, WD4RA, and WD4RC

Description	Model Code Identifier	Rating
Resistor Type	A	Carbon Fixed Resistor ^③
	B	Metal Film Resistor ^④
	C	Wire Wound Precision Resistor
Standard Resistance Range	A	1.0 Ohms to 100 Megohms
	B	10 Ohms to 4.75 Megohms
	C	55 Ohms to 250 Ohms
Resistance Tolerance	A	± 5%
	B	± 1%
	C	± 1%
Power Rating (Resistor) Maximum Continuous Watts at 30°C Ambient	A	0.5 Watts
	B	0.25 Watts
	C	0.5 Watts
Rated Continuous Working Voltage (Resistor)	A	$\sqrt{0.5 \times R}$ or 300V Max.
	B	$\sqrt{0.25 \times R}$ or 250V Max.
	C	$\sqrt{0.5 \times R}$ or 250V Max.
Operating Ambient Temperature Range	All	-20° to +40°C
Storage Temperature Range	All	-40° to +75°C
Dielectric Withstanding Voltage (Resistor)	A	700 Volts
	B & C	500 Volts

^① Performance Data — See Page Important-2.

^② The maximum voltage rating of the diode terminal blocks listed in the above table should not be exceeded even though the maximum reverse voltage rating of the diode alone is 1000V.

^③ The power rating of the resistor block operating in ambient temperatures of 30°C to 40°C should be derated for maximum resistor life. The derating curve is linear between 30°C and 40°C where the power rating is 100% of specified power at 30°C and 85% at 40°C.

^④ For further information on resistor performance consult your nearest Allen-Bradley Sales Office.

Bulletin 1492
Technical Specifications

RESISTOR CODES FOR 1492-RD3RB . . . , H2RB . . . , and HM2RB TERMINAL BLOCKS

Ordering Information

In order to complete the catalog number for **1492-RD3RB . . . , 1492-H2RB . . . , or 1492-HM2RB...** add the desired resistor code from the table below.

Example: Catalog Number **1492-RD3RB101** is a resistor terminal block with a 100 Ohm-1/4 Watt resistor.

Resistor Value (Ohms)	Resistor Code	Resistor Value (Ohms)	Resistor Code	Resistor Value (Ohms)	Resistor Code	Resistor Value (Ohms)	Resistor Code
10	100	432	431	22100	223	0.909M	914
11	110	475	471	24300	243	1.0M	105
12.1	120	511	511	26700	273	1.1M	115
13	130	562	561	30100	303	1.24M	125
15	150	619	621	33200	333	1.3M	135
16	160	681	681	35700	363	1.5M	155
18.2	180	750	751	39200	393	1.62M	165
20	200	825	821	43200	433	1.82M	185
22.1	220	909	910	47500	473	2.0M	205
24.3	240	1000	102	51100	513	2.21M	225
26.7	270	1100	112	56200	563	2.43M	245
30.1	300	1210	122	61900	623	2.67M	275
33.2	330	1300	132	68100	683	3.01M	305
35.7	360	1500	152	75000	753	3.32M	335
39.2	390	1620	162	82500	823	3.57M	365
43.2	430	1820	182	90900	913	3.92M	395
47.5	470	2000	202	0.10M	104	4.32M	435
51.1	510	2210	222	0.11M	114	4.75M	475
56.2	560	2430	242	0.121M	124		
61.9	620	2670	272	0.13M	134		
68.1	680	2940	302	0.15M	154		
75	750	3320	332	0.162M	164		
82.5	820	3570	362	0.182M	184		
90.9	910	3920	392	0.20M	204		
100	101	4750	472	0.221M	224		
110	111	5110	512	0.243M	244		
121	121	5620	562	0.267M	274		
130	131	6810	682	0.301M	304		
150	151	7500	752	0.332M	334		
162	161	8250	822	0.357M	364		
182	181	9090	912	0.392M	394		
200	201	10000	103	0.432M	434		
221	221	11000	113	0.475M	474		
243	241	12100	123	0.511M	514		
267	271	13000	133	0.562M	564		
301	301	15000	153	0.619M	624		
332	331	16200	163	0.681M	684		
357	361	18200	183	0.75M	754		
392	391	20000	203	0.825M	824		

RESISTOR CODES FOR 1492-H2RA . . . , HM2RA . . . , and WD4RA . . . TERMINAL BLOCKS

Ordering Information

In order to complete the catalog number for **1492-H2RA . . . , 1492-HM2RA . . . , or 1492-WD4RA...** add the desired resistor code from the table below.

Example: Catalog Number **1492-H2RA101** is a resistor terminal block with a 100 Ohm-1/2 Watt resistor.

Resistor Value (Ohms)	Resistor Code	Resistor Value (Ohms)	Resistor Code	Resistor Value (Ohms)	Resistor Code	Resistor Value (Ohms)	Resistor Code	Resistor Value (Ohms)	Resistor Code
1.0	10G	43	430	1800	182	75000	753	3.3M	335
1.1	11G	47	470	2000	202	82000	823	3.6M	365
1.2	12G	51	510	2200	222	91000	913	3.9M	395
1.3	13G	56	560	2400	242	0.10M	104	4.3M	435
1.5	15G	62	620	2700	272	0.11M	114	4.7M	475
1.6	16G	68	680	3000	302	0.12M	124	5.1M	515
1.8	18G	75	750	3300	332	0.13M	134	5.6M	565
2.0	20G	82	820	3600	362	0.15M	154	6.2M	625
2.2	22G	91	910	3900	392	0.16M	164	6.8M	685
2.4	24G	100	101	4300	432	0.18M	184	7.5M	755
2.7	27G	110	111	4700	472	0.20M	204	8.2M	825
3.0	30G	120	121	5100	512	0.22M	224	9.1M	915
3.3	33G	130	131	5600	562	0.24M	244	10M	106
3.6	36G	150	151	6200	622	0.27M	274	11M	116
3.9	39G	160	161	6800	682	0.30M	304	12M	126
4.3	43G	180	181	7500	752	0.33M	334	13M	136
4.7	47G	200	201	8200	822	0.36M	364	15M	156
5.1	51G	220	221	9100	912	0.39M	394	16M	166
5.6	56G	240	241	10000	103	0.43M	434	18M	186
6.2	62G	270	271	11000	113	0.47M	474	20M	206
6.8	68G	300	301	12000	123	0.51M	514	22M	226
7.5	75G	330	331	13000	133	0.56M	564	24M	246
8.2	82G	360	361	15000	153	0.62M	624	27M	276
9.1	91G	390	391	16000	163	0.68M	684	30M	306
10	100	430	431	18000	183	0.75M	754	33M	336
11	110	470	471	20000	203	0.82M	824	36M	366
12	120	510	511	22000	223	0.91M	914	39M	396
13	130	560	561	24000	243	1.0M	105	43M	436
15	150	620	621	27000	273	1.1M	115	47M	476
16	160	680	681	30000	303	1.2M	125	51M	516
18	180	750	751	33000	333	1.3M	135	56M	566
20	200	820	821	36000	363	1.5M	155	62M	626
22	220	910	911	39000	393	1.6M	165	68M	686
24	240	1000	102	43000	433	1.8M	185	75M	756
27	270	1100	112	47000	473	2.0M	205	82M	826
30	300	1200	122	51000	513	2.2M	225	91M	916
33	330	1300	132	56000	563	2.4M	245	100M	107
36	360	1500	152	62000	623	2.7M	275		
39	390	1600	162	68000	683	3.0M	305		

SURGE SUPPRESSOR PERFORMANCE CHARACTERISTICS AND ELECTRICAL COMPONENT DATA^①

SURGE SUPPRESSOR TERMINAL BLOCKS					
Performance Characteristic	Catalog Number				
	1492-H2K024 1492-HM2K024	1492-H2K120 1492-HM2K120	1492-H2K240 1492-HM2K240	1492-RD3SS 1492-WD4SS 1492-WD4PSS 1492-WDG4PSS 1492-WD4PSSTP 1492-WDG4PSSTP	1492-WDG4NSS
Nominal Working Voltage (Volts AC or DC)	24	120	240	120	230
Maximum AC Working Voltage RMS Continuous (60 Hz)	30	140	275	140	275
Maximum DC Working Voltage Continuous	38	180	369	180	350
Maximum Clamping Voltage at Current I _p (8/20 μs Pulse)	92 Volts I _p = 6A	360 Volts I _p = 14A	710 Volts I _p = 17A	360 Volts I _p = 10A	710 Volts I _p > 50A
Maximum Voltage Rate of Rise Bulletin 100 Contactors Types A38 through B180 Bulletin 500 Contactors & Starters, Size 0 through 5 Bulletin 700 Relays	—	< 10 V/μs	< 10 V/μs	—	—
Peak Current (8/20 μs Pulse)	250A	150A	150A	1200A	4500A
Typical Leakage Current at Nominal AC Working Voltage	1.0mA	4.5mA	10.0mA	—	—
Typical Leakage Current at Nominal AC Working Voltage	—	—	—	< 0.1mA	< 0.1mA
Metal Oxide Varistor (MOV) Maximum Clamping Voltage at Current I _p (8/20 μs Pulse) Maximum Transient Energy Maximum Power Dissipation	—	—	—	360 Volts I _p = 10A 12 joules 0.25 Watts	710 Volts I _p = 50A 71 joules 0.6 Watts

Component Specifications

Characteristic	Suppressor Catalog Number		
	1492-H2K024 1492-HM2K024	1492-H2K120 1492-HM2K120	1492-H2K240 1492-HM2K240
Capacitor Nominal Value Tolerance Maximum DC Working Voltage	0.10 μF ± 20% 500 Volts DC	0.10 μF ± 20% 500 Volts DC	0.10 μF ± 20% 500 Volts DC
Metal Oxide Varistor (MOV) Maximum Clamping Voltage at Current I _p (8/20 μs Pulse) Maximum Transient Energy Maximum Power Dissipation	92 Volts I _p = 5A 1.8 joules 0.25 Watts	360 Volts I _p = 10A 12 joules 0.25 Watts	710 Volts I _p = 10A 23 joules 0.25 Watts
Resistor Nominal Value Tolerance Power Rating	100 Ohms ± 20% 2 Watts at +40°C	100 Ohms ± 20% 2 Watts at +40°C	100 Ohms ± 20% 2 Watts at +40°C

TECHNICAL SPECIFICATIONS FOR FUSE PLUGS^②

Characteristic	1492-FP4	1492-FP424	1492-FP4250
Indicator Type	Non-Indicating	LED	Neon
Leakage Current	—	2mA @ 24V	1mA @ 264V
Working Voltage	Per Fuse Rating	10-57V AC/DC	85-264V AC
Fuse Size (Not Supplied)	5 X 20 mm	5 X 20 mm	5 X 20 mm

① Performance Data — See Page Important-2.

Performance data given in this catalog is provided as a guide for the user in determining suitability and does not constitute a warranty. It may represent the result of accelerated testing at elevated stress levels and the user should correlate it to actual application requirements. Actual performance is subject to Allen-Bradley WARRANTY and LIMIT OF LIABILITY.

② Maximum current rating for the fuse plug is 10 amps at 250 volts. IEC standards for 5x20 mm fuses do not include ratings above 6.3 Amps.

UL/CSA FILE AND GUIDE NUMBERS ARRANGED BY BASE CATALOG NUMBERS

Base Catalog Number	UL Number		CSA Number	
	File	Guide	File	Class
1492-CA, -CE, -CD	E40735	XCFR2	LR67896	622801
1492-CB	E65138	QVNU2	LR37712	9091-01
1492-CE6	E34648	IZLT2	LR67896	622801
1492-EC85, -ED103	E40735	XCFR2	—	—
1492-F	E40735	XCFR2	LR67896	622801
1492-FB	E34648	IZLT	LR70915	622501
1492-GH, -GS	E65138	QVNU2	LR67768	9091-01
1492-H1, -H2, -HM1, -HM2, -HM3	E40735	XCFR2	LR67896	622801
1492-H4, -H5, -H6, -H7	E40735	XCFR2	LR67896	622801
1492-HC6, -HJ	E40735	XCFR2	LR67896	622801
1492-IFM, -AIFM	E113724	NRAQ2	LR1234	321107
1492-PD, -50, -100	E40735	XCFR2	LR19766	905204
1492-R	E40735	XCFR2	E40735❶	XCFR8❶
1492-RG	E160646	KDER2	E160646❶	KDER8❶
1492-UF3	E40735	XCFR2	LR67896	622801
1492-W ❷	E40735	XCFR2	LR67896 LR14074	622801 622801
1492-WG ❷	E160646	KDER2	LR67896 LR14074	622801 622801

❶ These numbers are actually UL file and guide numbers, as these products are UL recognized components per Canadian Safety Standards (cUR).

❷ All extensions of this product number are recognized except **WTC3***.

NOTES